



[Manuals.plus](#) /

> [DAMNISS](#) /

> DAMNISS Wood Pellet Grill & Smoker Instruction Manual

## DAMNISS DAMNISS-Wood Pellet Grill001

# DAMNISS Wood Pellet Grill & Smoker Instruction Manual

Brand: DAMNISS | Model: DAMNISS-Wood Pellet Grill001

## 1. PRODUCT OVERVIEW

The DAMNISS Wood Pellet Grill & Smoker is an 8-in-1 versatile outdoor cooking appliance designed for grilling, smoking, baking, roasting, searing, braising, barbecuing, and char-grilling. It features advanced PID intelligent temperature control technology for consistent cooking results and a substantial 456 sq. in. grilling space.



Image: The DAMNISS Wood Pellet Grill and Smoker, shown with its included rain cover.

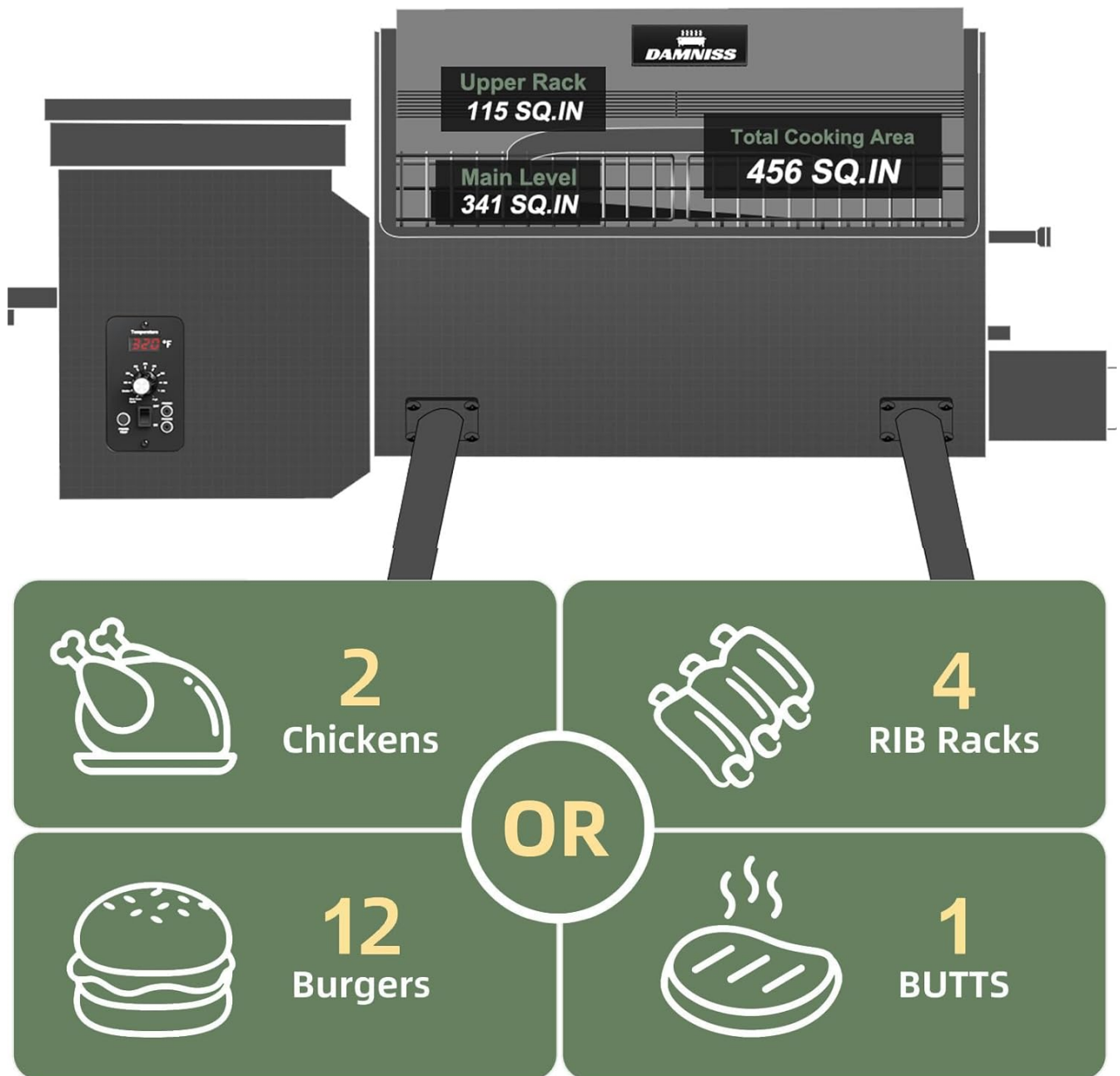

Image: Diagram illustrating the total cooking area of 456 square inches, comprising a 341 sq. in. main level and a 115 sq. in. upper rack, along with capacity examples like 2 chickens, 4 rib racks, or 12 burgers.

## 2. SETUP AND ASSEMBLY

Prior to first use, ensure all components are present and undamaged. Follow the detailed assembly instructions provided in the separate assembly guide. Once assembled, place the grill on a stable, level surface away from flammable materials.

### 2.1 Initial Preparation

- **Hopper Filling:** Fill the pellet hopper with up to 11 lbs of 100% natural hardwood pellets. Ensure the hopper lid is securely closed to protect pellets from moisture.
- **Power Connection:** Connect the grill to a grounded electrical outlet.
- **Burn-in Process:** Before cooking food, perform an initial burn-in cycle to season the grill and remove any manufacturing residues. Refer to the specific burn-in instructions in your assembly guide.

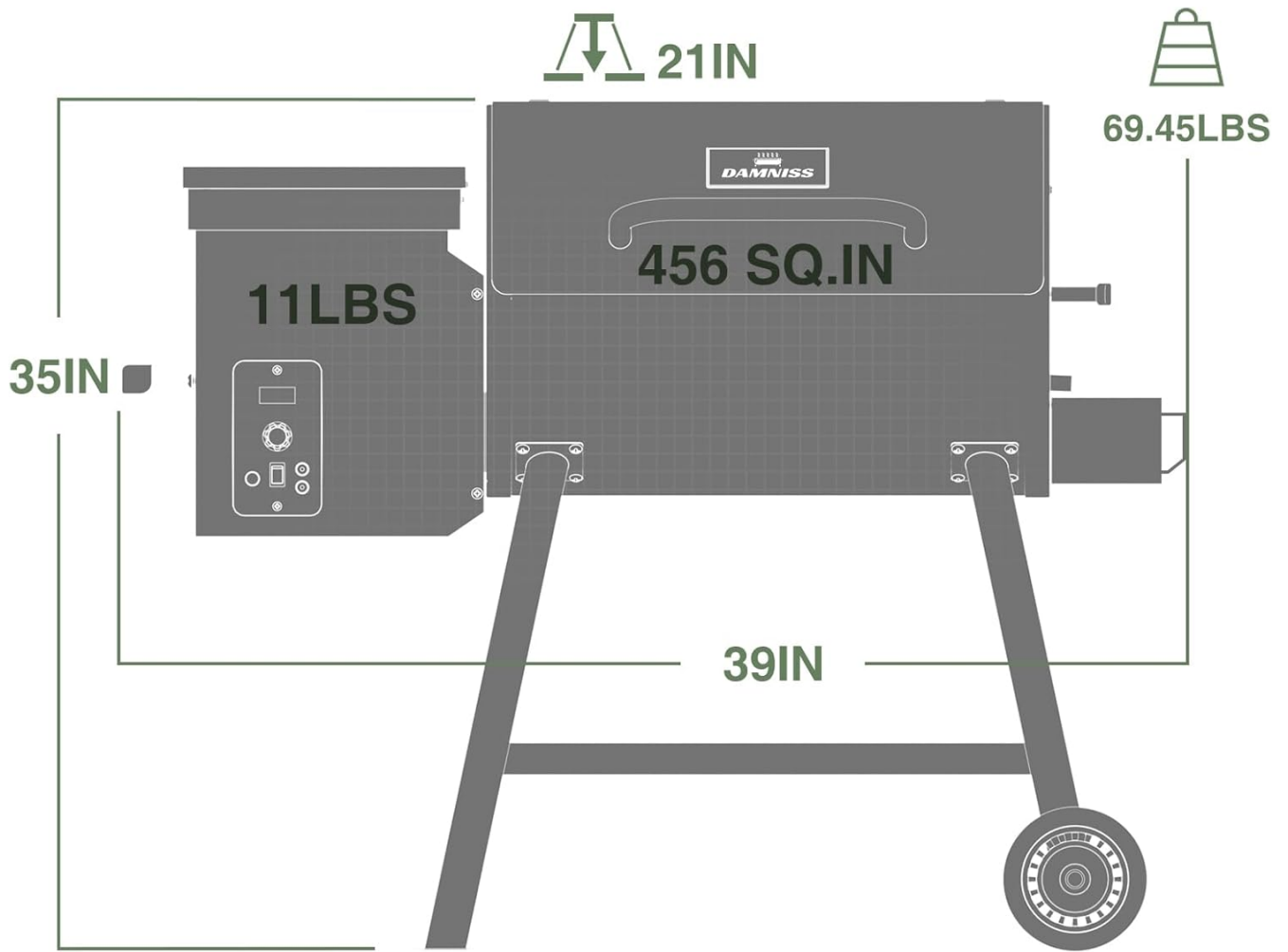

<p><b>GRILL Capacity</b></p>	<p><b>2</b> Chickens</p> 	<p><b>4</b> RIB Packs</p> 	<p><b>12</b> Burgers</p> 
----------------------------------	--	--	--

Image: Technical diagram displaying the dimensions (35 inches height, 39 inches length, 21 inches width) and weight (69.45 lbs) of the grill, along with the 11 lbs hopper capacity and 456 sq. in. cooking area.

# Automatic BBQ & Wood-Smoked Flavors

Use natural hardwood pellets, which infuse food with a rich, smoky flavor.

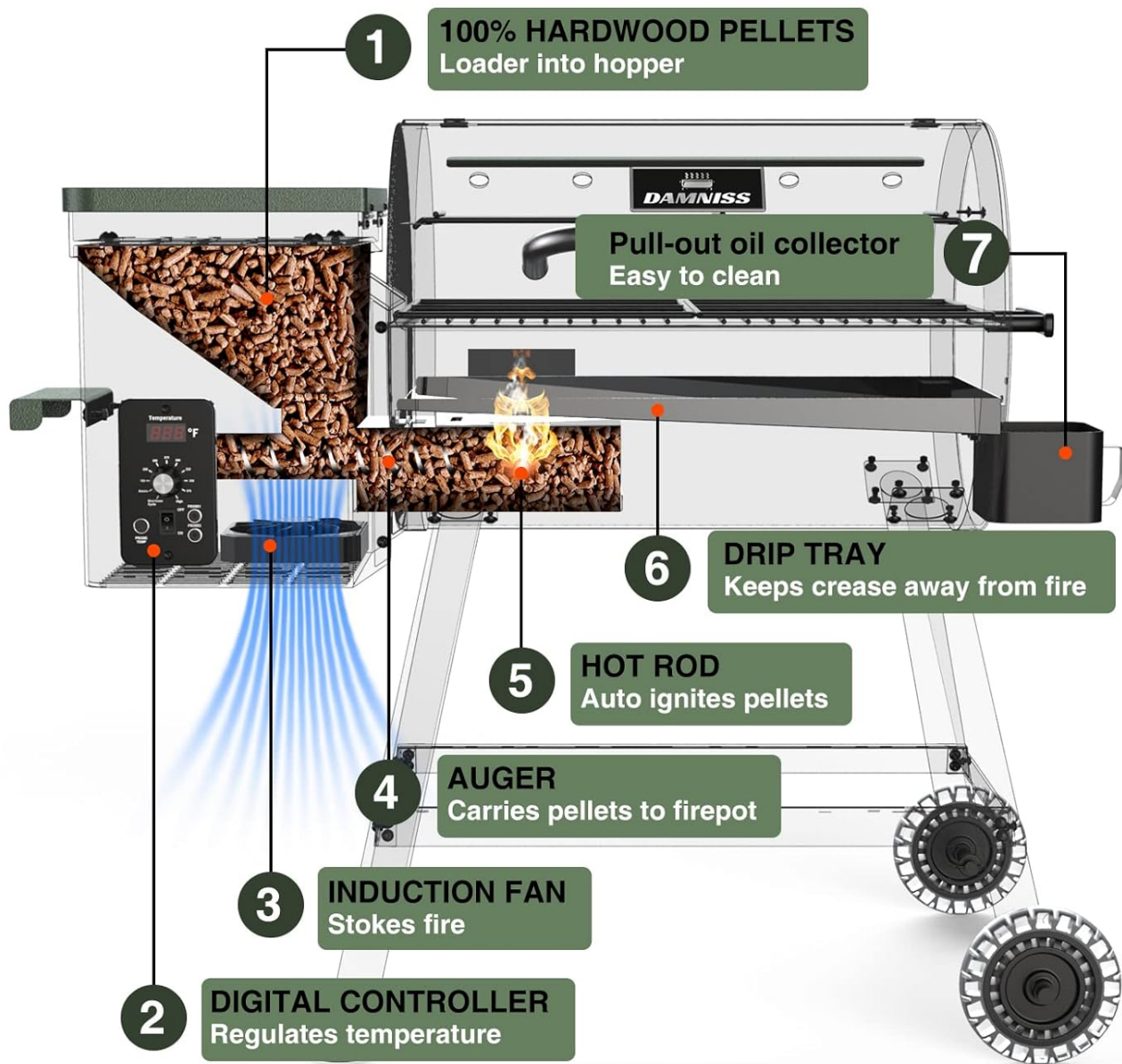

Image: An exploded view diagram detailing the internal workings of the pellet grill, including the pellet hopper, digital controller, induction fan, auger, hot rod igniter, drip tray, and pull-out oil collector.

## 3. OPERATING INSTRUCTIONS

The DAMNISS Wood Pellet Grill offers precise temperature control and versatile cooking options.

### 3.1 Temperature Control

Utilize the PID intelligent temperature control system to set your desired cooking temperature between 180°F and 450°F. The digital controller maintains a stable temperature, ensuring consistent results for various cooking methods.

- **Setting Temperature:** Use the control knob to select the desired temperature. The digital display will show the current internal temperature.
- **Preheating:** Allow the grill to preheat to the set temperature before placing food inside.

- **Smoke Setting:** A dedicated smoke setting is available for low-and-slow cooking, infusing food with rich wood-fired flavor.



Image: A visual representation of how the grill produces automatic BBQ and wood-smoked flavors, highlighting the pellet loading, digital control, fan, auger, hot rod, and drip tray.

### 3.2 8-in-1 Versatility

This grill allows for multiple cooking styles:

- **Grill:** Direct heat cooking for searing and charring.
- **Char-Grill:** Achieve distinct grill marks and smoky flavor.
- **Bake:** Use indirect heat for baking items like pizzas or desserts.
- **BBQ:** Classic barbecue cooking with smoky flavor.
- **Smoke:** Low and slow cooking for tender, flavorful meats.
- **Braise:** Cook food slowly in liquid for tender results.
- **Roast:** Roast meats and vegetables evenly.
- **Sear:** High-temperature cooking for a crispy exterior.

# HOW IT WORKS

## Fill

Fill the hopper with up to 11lbs



## Set & Leave

Pick desired temperature, and let it do the rest



## Enjoy

Enjoy delicious BBQ with friends and families.



Image: A family and friends gathered around the DAMNISS Wood Pellet Grill, enjoying a barbecue, demonstrating the ease of use: fill, set temperature, and enjoy.

## 4. MAINTENANCE AND CARE

Regular maintenance ensures the longevity and optimal performance of your DAMNISS Wood Pellet Grill.

### 4.1 Cleaning

- **Grates:** Clean cooking grates after each use with a grill brush.
- **Drip Tray:** Regularly empty and clean the pull-out oil collector and drip tray to prevent grease fires.
- **Ash Clean-out:** Periodically remove ash from the firepot and ash collection system.
- **Exterior:** Wipe down the exterior with a damp cloth. Avoid abrasive cleaners.

### 4.2 Storage

When not in use, especially during inclement weather, protect your grill with the included rain cover. The rugged wheels allow for easy portability across various terrains for convenient storage.

## Rugged Wheels Easily Fit Any Backyard Terrain



Image: A person easily moving the DAMNISS Wood Pellet Grill across a grassy backyard, highlighting its rugged wheels designed for various terrains.



Image: The DAMNISS Wood Pellet Grill and Smoker, shown with its durable rain cover, emphasizing protection against elements.

## 5. TROUBLESHOOTING

If you encounter any issues with your DAMNISS Wood Pellet Grill, please refer to the comprehensive troubleshooting section in your full user manual or visit the official DAMNISS support website. Common issues often relate to pellet quality, auger jams, or temperature sensor readings.

For immediate assistance, ensure the grill is properly connected to power, the hopper has sufficient pellets, and all components are clean and free of obstructions.

## 6. SPECIFICATIONS

Feature	Detail
Brand	DAMNISS
Model Name	Wood Pellet Grill
Model Number	DAMNISS-Wood Pellet Grill001
Power Source	Solid Fuel
Color	Green
Outer Material	Stainless Steel
Inner Material	stainless steel
Item Weight	82 Pounds
Product Dimensions	24"D x 45.5"W x 36.5"H
Fuel Type	Electric, Wood Pellet
Form Factor	Combo
Total Cooking Area	456 sq. in.
Temperature Range	180-450°F
Hopper Capacity	Up to 11 lbs

## 7. OFFICIAL PRODUCT VIDEOS

Currently, there are no official product videos from the seller available for embedding in this manual. Please refer to the product listing page for any customer-uploaded videos.

## 8. WARRANTY AND SUPPORT

For information regarding product warranty, returns, or customer support, please refer to the warranty card included with your purchase or visit the official DAMNISS website. You may also contact Amazon customer service for assistance with your order.

**Customer Support:** [Amazon Customer Service](#)