

Manuals+

[Q & A](#) | [Deep Search](#) | [Upload](#)

manuals.plus /

› [PTCYIDU](#) /

› [PTCYIDU 110V 400W PTC Fan Heater Instruction Manual](#)

PTCYIDU 110v

PTCYIDU 110V 400W PTC Fan Heater Instruction Manual

Model: 110v

1. INTRODUCTION

This manual provides essential information for the safe and efficient operation of your PTCYIDU 110V 400W PTC Fan Heater. Please read these instructions thoroughly before installation and use, and retain them for future reference.



Image 1.1: The PTCYIDU 110V 400W PTC Fan Heater, showing the compact heating unit and its accompanying power cord.

2. SAFETY INFORMATION

Always observe the following safety precautions to prevent injury or damage to the product:

- Ensure the power supply voltage matches the heater's rated voltage (110V).
- Do not immerse the heater in water or other liquids.
- Avoid blocking the air inlet or outlet of the fan heater.
- Keep flammable materials away from the heater during operation.
- The heater surface can become hot; avoid direct contact during and immediately after use.
- This product is designed with surface insulation for safety. However, proper installation and handling are crucial.
- Disconnect power before performing any maintenance or installation.

3. PRODUCT COMPONENTS

The PTCYIDU 110V 400W PTC Fan Heater consists of the following main components:

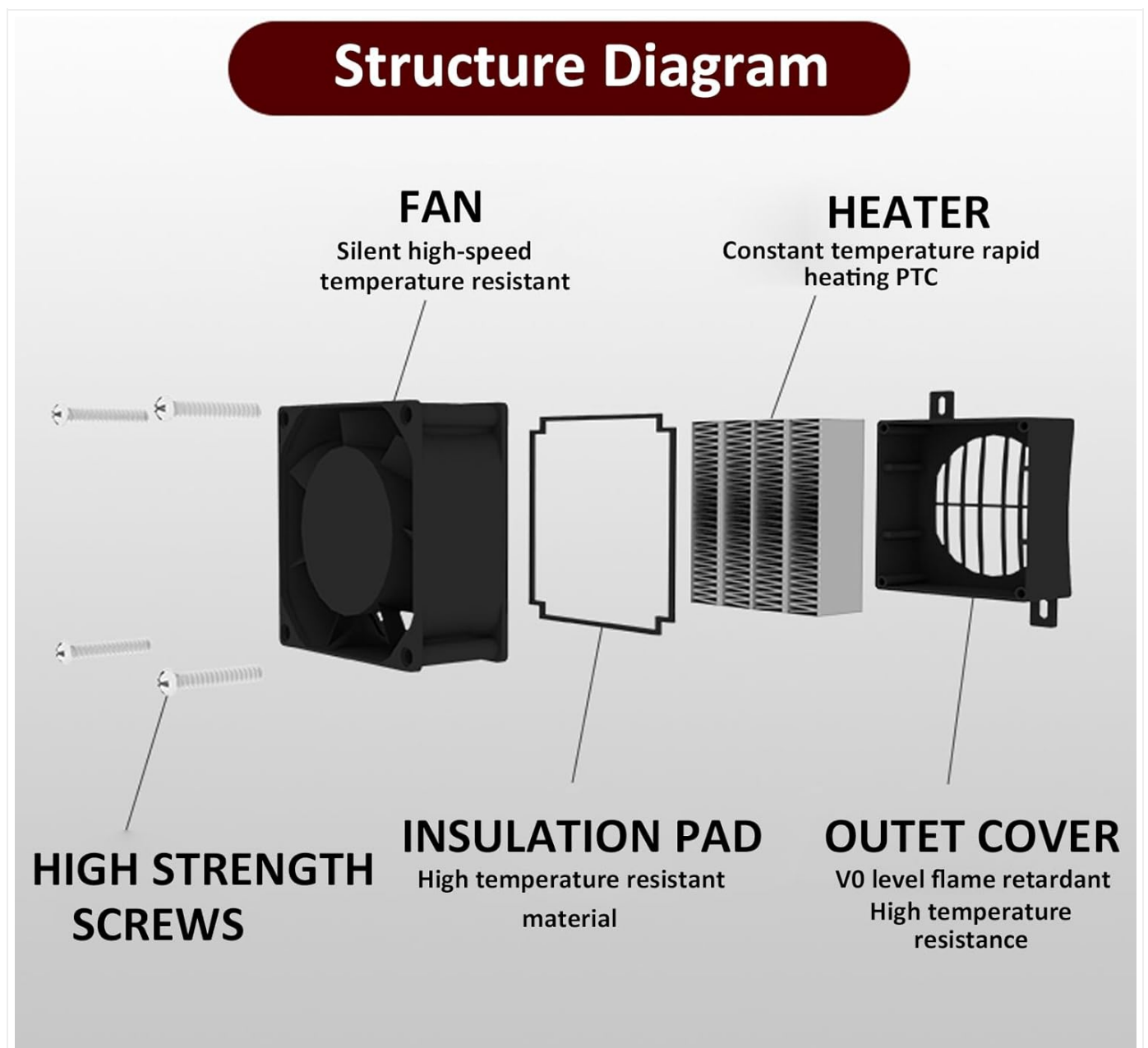

Image 3.1: Exploded view illustrating the internal components of the PTC Fan Heater, including the fan, insulation pad, heating element, outer cover, and mounting screws.

- **Fan**: Silent high-speed, temperature-resistant fan for air circulation.
- **Insulation Pad**: High temperature resistant material for safety.

- **Heater:** Constant temperature rapid heating PTC ceramic element.
- **Outer Cover:** V0 level flame retardant material with high temperature resistance.
- **High Strength Screws:** For secure mounting.
- **Power Cord:** For connecting to a 110V power source.

4. SPECIFICATIONS

Feature	Detail
Brand	PTCYIDU
Model Number	110v
Rated Voltage	110 Volts
Rated Power	400 Watts ($\pm 20\%$)
Fan Rated Voltage	220V (Note: Fan voltage is separate from heater voltage)
Rated Current	3.7 Amps ($\pm 20\%$)
Inrush Power	$\leq 590W$ ($\pm 20\%$)
PTC Withstand Voltage	110V
Fan Withstand Voltage	220V
Chip Temperature	TS260
Product Dimensions	5.9"D x 3.54"W x 4.33"H (approx. 15cm D x 9cm W x 11cm H)
Item Weight	14 ounces
Special Feature	Portable
Indoor/Outdoor Usage	Indoor
Fuel Type	Electric

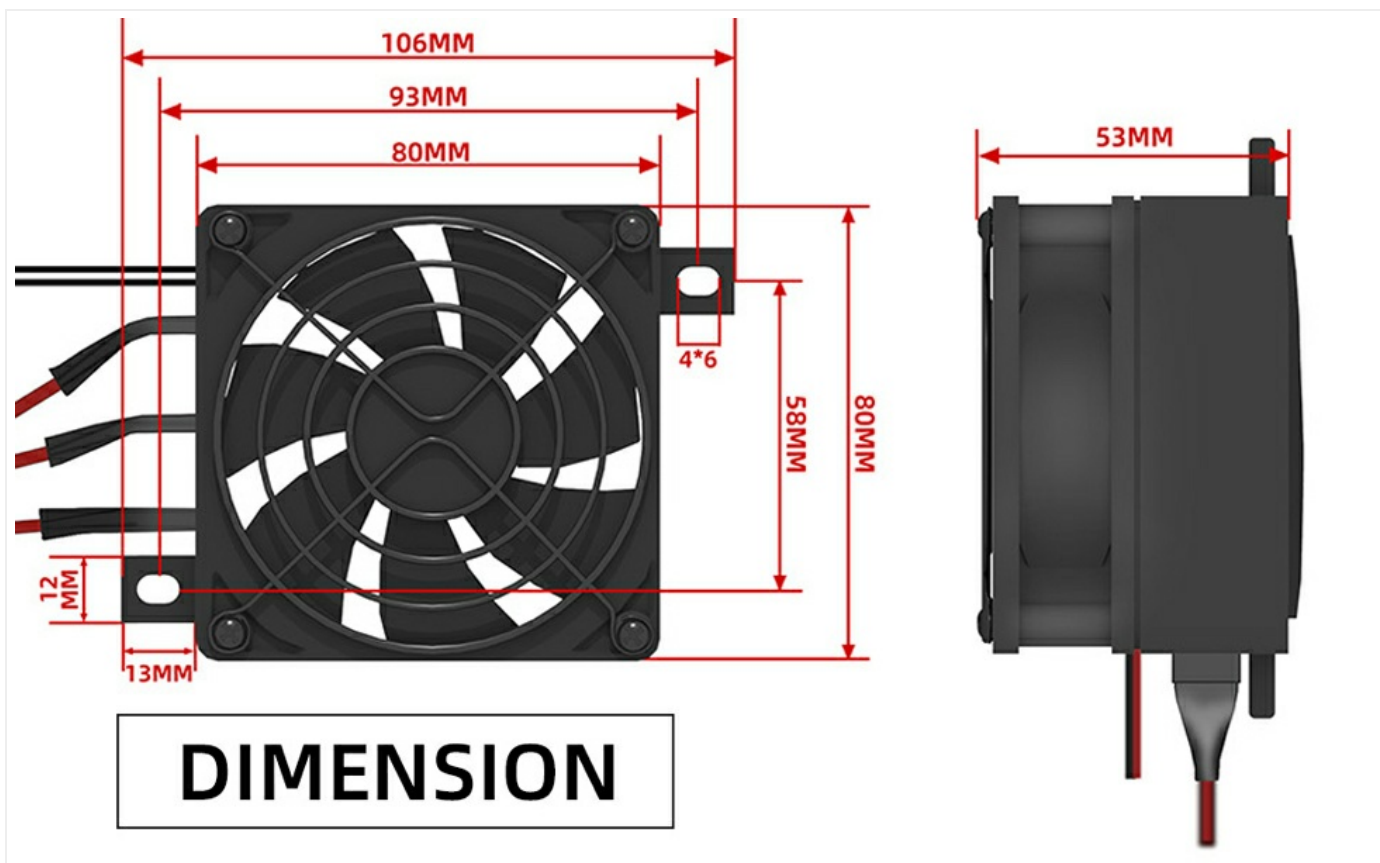

Image 4.1: Technical drawing showing the precise dimensions of the PTC Fan Heater in millimeters and inches.

Fan heater parameters R_{≈25°C}

Product Code	Rated Voltage	Fan Rated Voltage	Rated Power (±20%)	Inrush Power (±20%)
PTC Fan Heater-110v 400w	110V	220V	400W	≤ 590W
PTC Withstand Voltage	Fan Withstand Voltage	Rated Current (±20%)	Impulse Current (±20%)	Chip Temperature
110V	220V	3.7A	< 5A	TS260



Image 4.2: Table detailing the fan heater parameters including voltage, power, current, and chip temperature at approximately 25°C room temperature.

5. SETUP AND INSTALLATION

The PTCYIDU fan heater is designed for easy installation in small spaces. Follow these steps for proper setup:

1. **Unpack:** Carefully remove the heater and power cord from its packaging. Inspect for any visible damage.
2. **Mounting:** The heater features integrated mounting holes. Secure the unit using appropriate screws (refer to Image 3.1 for screw locations) in a stable, heat-resistant location. Ensure adequate clearance around the air inlet and outlet for proper airflow.
3. **Wiring:** Connect the provided power cord to the heater's terminals. Ensure connections are secure and insulated. The heater is designed for 110V operation.
4. **Placement:** Position the heater in the desired small space (e.g., within 0.5 cubic meters) where heating, dehumidifying, or warmth preservation is needed.



NEW Type



OLD Type

Image 5.1: Illustration showing the 'NEW Type' PTC Fan Heater with its power cord and the 'OLD Type' for comparison, highlighting the integrated power cord for the new model.

6. OPERATING INSTRUCTIONS

The PTCYIDU fan heater operates simply once installed:

1. **Power On:** Plug the power cord into a standard 110V electrical outlet. The heater will begin to operate immediately.
2. **Automatic Constant Temperature:** The PTC heating element features automatic constant temperature control. It will heat rapidly and maintain a stable temperature without external adjustment.
3. **Power Fluctuation:** Note that the actual power consumption can vary based on environmental conditions and heat dissipation. Better heat dissipation generally leads to higher power output within its rated range.
4. **Testing Conditions:** For accurate performance assessment, test the unit at room temperature, ideally around 25°C.
5. **Power Off:** To turn off the heater, simply unplug it from the power outlet.



Image 6.1: Close-up views highlighting the PTC ceramic heating element, the terminals for wiring, and the power connector for easy installation and operation.

7. MAINTENANCE

Minimal maintenance is required for the PTCYIDU fan heater. Follow these guidelines to ensure longevity:

- **Cleaning:** Ensure the heater is unplugged and completely cool before cleaning. Use a soft, dry cloth to wipe the exterior. Do not use abrasive cleaners or allow water to enter the unit.
- **Airflow:** Periodically check that the fan and heating fins are free from dust and debris to maintain optimal airflow and heating efficiency. Use a soft brush or compressed air if necessary.
- **Storage:** When not in use for extended periods, store the heater in a cool, dry place, away from direct sunlight and moisture.

8. TROUBLESHOOTING

If you encounter issues with your PTCYIDU fan heater, refer to the following common troubleshooting points:

- **Heater not turning on:**
 - Ensure the power cord is securely plugged into a functional 110V outlet.
 - Check for any tripped circuit breakers or blown fuses in your electrical system.
- **Insufficient heat output:**
 - Verify that the air inlet and outlet are not obstructed, allowing for proper heat dissipation.
 - The power of PTC heating plates is not a fixed value but a range. Better heat dissipation results in greater power output. Ensure the environment allows for efficient heat transfer.
 - The dry burning power is approximately 20% of the maximum power. Ensure the heater is operating in conditions that allow for optimal heat transfer.

- **Unusual noise:**

- Check for any foreign objects obstructing the fan blades.
- Ensure the heater is securely mounted and not vibrating against other surfaces.

- **Overheating:** The PTC element has inherent safety features. If the unit feels excessively hot, ensure it is not in an enclosed space without adequate ventilation.

If problems persist after attempting these troubleshooting steps, please contact customer support.

9. APPLICATIONS

The PTCYIDU 110V 400W PTC Fan Heater is suitable for various small space heating applications, including:

- Automobile heaters
- Electrical thermostat incubators
- Small instruments
- Small box space temperature heating (within 0.5m³)
- 3D printer enclosures



Image 9.1: Visual examples of the PTC Fan Heater's wide range of applications, such as maintaining temperature in 3D printer enclosures, warming car interiors, and providing heat for small incubators.

10. CUSTOMER SUPPORT

For any questions regarding your PTCYIDU PTC Fan Heater or other products, please contact our customer support team. We are committed to providing reliable and energy-efficient heating solutions.

You can typically find contact information on the product packaging or through the retailer's website where the product was purchased.



© 2023 PTCYIDU. All rights reserved.