



[Manuals.plus](#) /

> [Pavv](#) /

> Pavv 6DOF Robot Mechanical Arm Kit User Manual

Pavv MG996R

Pavv 6DOF Robot Mechanical Arm Kit User Manual

Model: MG996R

INTRODUCTION

The Pavv 6DOF Robot Mechanical Arm Kit is designed for educational and DIY projects, particularly in college teaching and creator education. This kit provides a robust platform for understanding robotic manipulation, featuring six degrees of freedom powered by six servo motors. It is capable of demonstrating complex movements including forward/backward, up/down, and left/right gripping and carrying.



Figure 1: Fully assembled 6DOF Robot Mechanical Arm Kit.

PACKAGE CONTENTS

Before beginning assembly, please verify that all components listed below are present in your package:

- 6 x MG996 Analog Steering Gear (Servo Motors)
- 1 x Cable Tie
- 5 Packs Screw Nut Fittings (various sizes)
- 3 x Extension Cords
- 1 x Flange Rod
- 3 x Flange Bearings

- 6 x Metal Steering Wheels
- 1 x Mechanical Arm Base Plate
- 1 x Beam
- 1 x Different U-Shaped Bracket
- 2 x L-Shaped Brackets
- 2 x Long U Brackets
- 4 x Multi-Function Brackets



Figure 2: All components included in the kit.

SETUP AND ASSEMBLY

Assembly of the 6DOF Robot Mechanical Arm Kit requires careful attention to detail. While detailed step-by-step instructions are not provided in this manual, the following general guidelines and visual aids will assist in the construction process. It is recommended to refer to online resources or similar product assembly guides for comprehensive visual instructions.

1. **Prepare Components:** Lay out all components and identify each part according to the package contents list.
2. **Assemble Base:** Begin by assembling the base structure using the base plate and appropriate brackets.
3. **Attach Servos:** Securely attach the MG996 Analog Steering Gears (servos) to their designated positions on the arm's frame using the provided screws and nuts. Ensure correct orientation for each servo to allow for full range of motion.
4. **Connect Arm Segments:** Connect the various arm segments (U-shaped, L-shaped, and multi-function brackets) using the flange rod, flange bearings, and other fittings. Pay close attention to the pivot points and joint flexibility.
5. **Install Gripper:** Assemble the robotic clamp hand claw and attach it to the end of the arm.
6. **Wiring:** Connect the servo motors to your control board (not included) using the extension cords. Ensure proper polarity and pin assignments.



Figure 3: Example of arm segment assembly.

**Forearm mechanical structure: simplified structure, reduced forearm weight,
easier installation and more flexible control**

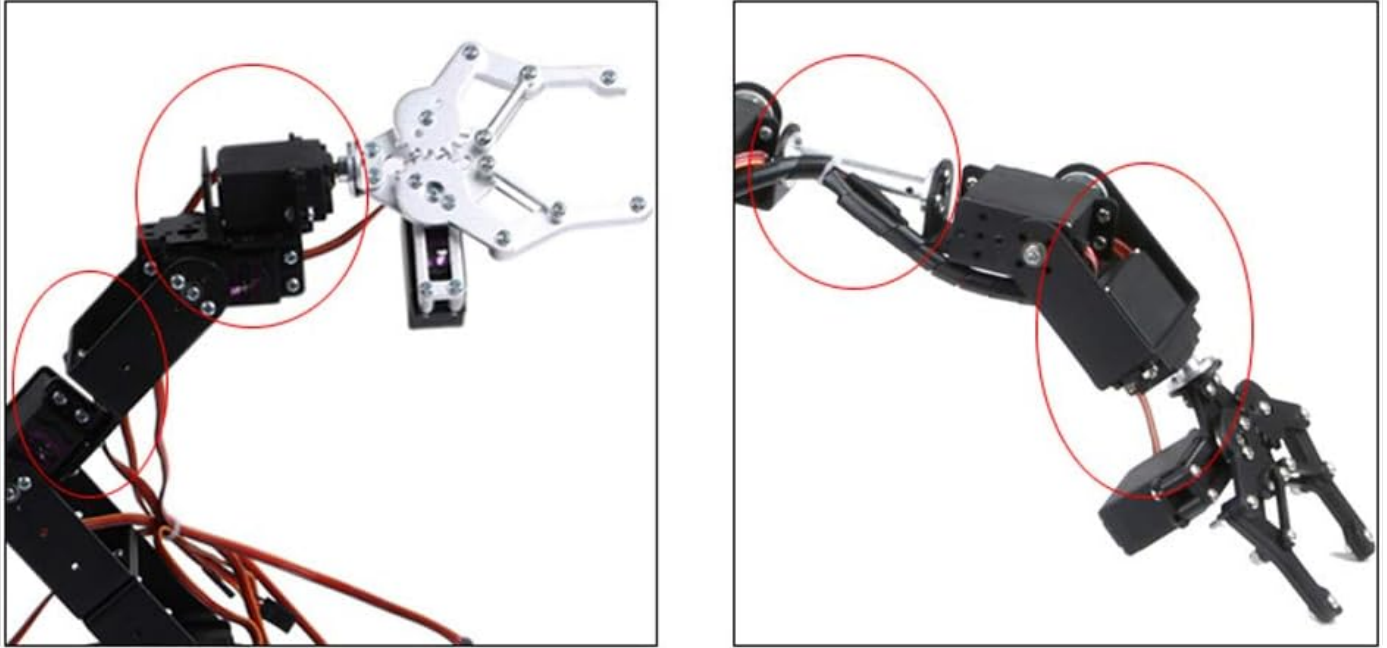

Figure 4: Detail of forearm mechanical structure, showing simplified design for easier installation and flexible control.

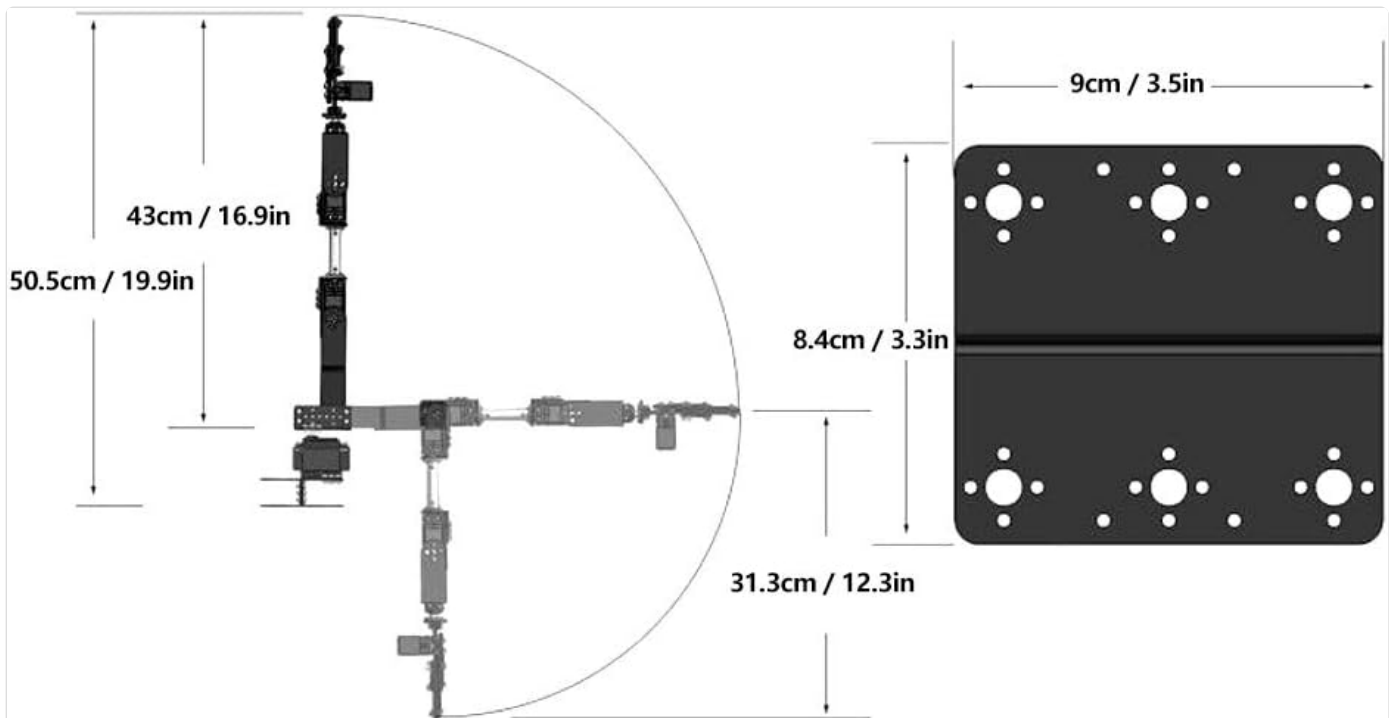

Figure 5: Additional view of the forearm structure, emphasizing the use of imported cup bearings for flexible steering.

OPERATING THE ROBOTIC ARM

The Pavv 6DOF Robot Mechanical Arm Kit is designed to be controlled via an external microcontroller (e.g., Arduino, Raspberry Pi) and appropriate programming. This kit does not include the control board or programming environment.

- **Power Supply:** Ensure your power supply meets the working voltage requirements of 4.8V-7.2V. An unstable power supply can lead to erratic servo behavior.
- **Programming:** Develop or load code onto your microcontroller to send control signals to each of the six servo motors. Each servo controls a specific joint, allowing for precise manipulation.

- **Movement:** Experiment with different servo angles (0-180 degrees) to understand the arm's range of motion and capabilities. The disc-shaped chassis allows for flexible left and right rotation of the entire manipulator.
- **Gripping:** Program the gripper servo to open and close the clamp hand claw for picking up and releasing objects.



Figure 6: The robot arm in an operational setting, demonstrating its use in educational or DIY projects.

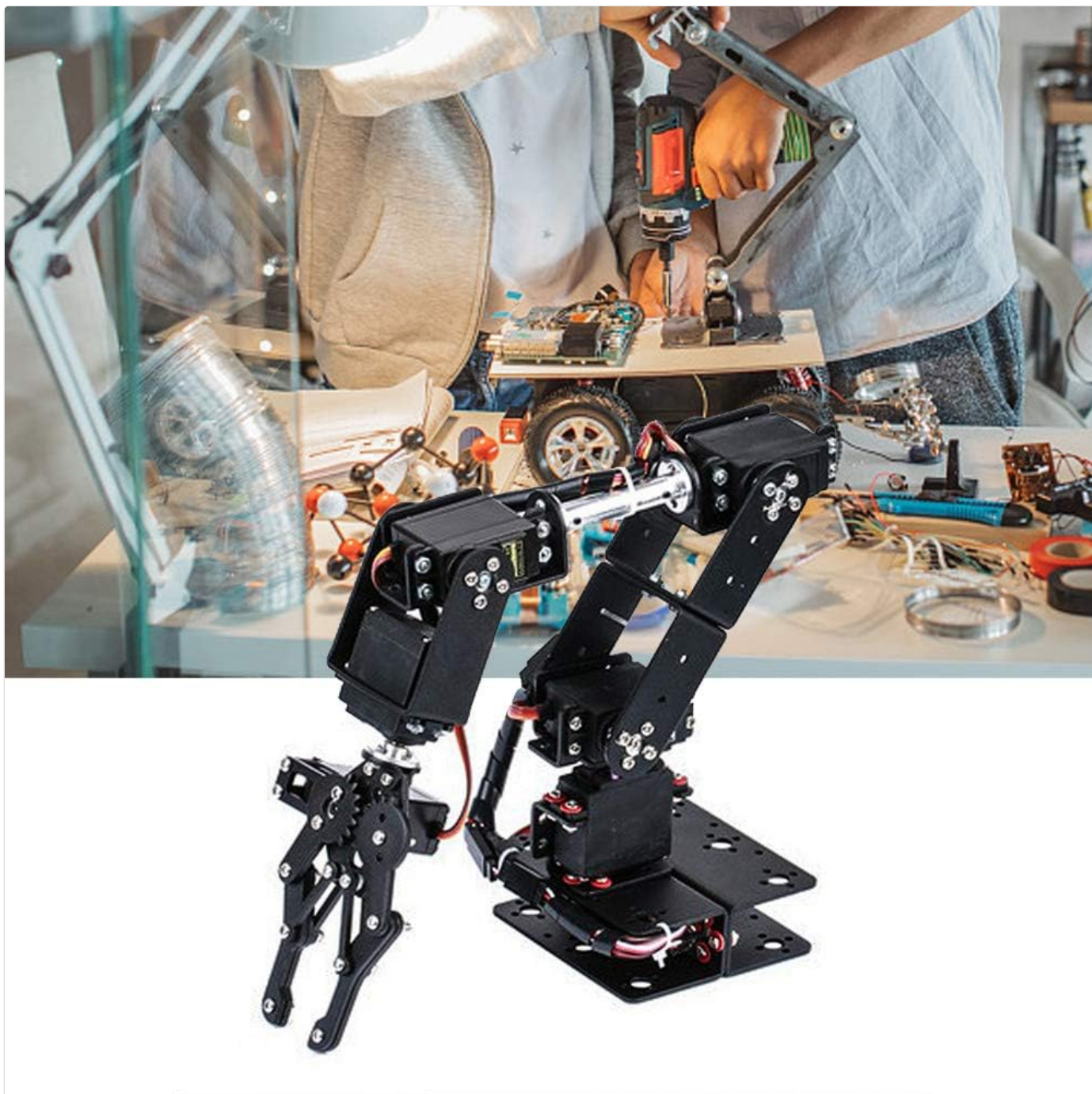

Figure 7: Close-up of a user interacting with the mechanical arm, highlighting its practical application.

MAINTENANCE

To ensure the longevity and optimal performance of your robotic arm, follow these maintenance guidelines:

- **Regular Inspection:** Periodically check all screws and connections to ensure they are tight. Loose fittings can affect stability and movement precision.
- **Cleanliness:** Keep the arm free from dust and debris. Use a soft, dry cloth for cleaning. Avoid using liquid cleaners directly on electronic components or servo motors.
- **Servo Care:** Avoid forcing the arm's joints beyond their natural range of motion (180 degrees for servos) as this can damage the internal gears. The metal gears in the MG996 servos offer good durability, but excessive strain should be avoided.
- **Storage:** When not in use, store the robotic arm in a clean, dry environment away from extreme temperatures and direct sunlight.

TROUBLESHOOTING

Problem	Possible Cause	Solution
Arm not moving or erratic movement	<ul style="list-style-type: none">◦ Insufficient or unstable power supply.◦ Incorrect wiring of servos.◦ Servo motor damage.◦ Programming error.	<ul style="list-style-type: none">◦ Verify power supply voltage (4.8V-7.2V) and current capacity.◦ Check all wiring connections for correct polarity and secure fit.◦ Test individual servos if possible. Replace damaged servos.◦ Review your control code for logical errors or incorrect servo commands.
Joints are stiff or grinding	<ul style="list-style-type: none">◦ Loose or overtightened screws at joints.◦ Misaligned components.◦ Damaged bearings or gears.	<ul style="list-style-type: none">◦ Inspect and adjust screw tightness at all pivot points.◦ Disassemble and reassemble affected sections, ensuring proper alignment.◦ Check bearings and servo gears for wear or damage. Replace if necessary.
Arm does not reach full range of motion	<ul style="list-style-type: none">◦ Physical obstruction.◦ Servo limit angle not set correctly in code.◦ Servo horn/wheel improperly attached.	<ul style="list-style-type: none">◦ Ensure no cables or structural parts are impeding movement.◦ Verify that your programming allows servos to reach their full 0-180 degree range.◦ Re-attach servo horns/wheels, ensuring they are centered at the servo's neutral position before tightening.

SPECIFICATIONS

Feature	Detail
Model Number	MG996R
Item Type	Mechanical Arm Kit
Color	Black
Degrees of Freedom (DOF)	6
Servo Motors Included	6 x MG996 Analog Steering Gear
Working Voltage	4.8V - 7.2V
No-load Current	100mA
Machine Torsion	10kg.cm
Limit Angle (Servos)	180°
Wire Length (Servos)	30cm
Gear Material (Servos)	Metal Gear
Dead Time (Servos)	5uS
Bracket Material	2mm thick Aluminum Plate

Feature	Detail
Package Dimensions	10.08 x 6.97 x 2.01 inches
Item Weight	1.94 pounds
Country of Origin	China
Recommended Age	6 months and up (Note: This is a complex kit, adult supervision or advanced user knowledge is recommended for assembly and programming.)



Figure 8: Dimensional overview of the assembled robotic arm and its base.

WARRANTY AND SUPPORT

Specific warranty details for the Pavv 6DOF Robot Mechanical Arm Kit are not provided in the product information. For any inquiries regarding warranty, technical support, or missing parts, please contact the seller or manufacturer directly through your purchase platform.

The manufacturer, Pavv, is committed to providing customer satisfaction. If you encounter any issues, please reach out to

the seller for assistance.

© 2024 Pavv. All rights reserved.
For educational and DIY use only.