



[Manuals.plus](#) /

> [TIPIACE](#) /

> TIPIACE Hard-Wired Motorized Zebra Blinds (Model HD-162) Instruction Manual

TIPIACE HD-162

TIPIACE Hard-Wired Motorized Zebra Blinds (Model HD-162) Instruction Manual

[Introduction](#) [Safety Information](#) [Package Contents](#) [Installation](#) [Product](#)
[Features](#) [Operation](#) [Maintenance](#) [Troubleshooting](#) [Specifications](#) [Warranty & Support](#)

1. INTRODUCTION

This manual provides detailed instructions for the installation, operation, and maintenance of your TIPIACE Hard-Wired Motorized Zebra Blinds, Model HD-162. Please read this manual thoroughly before installation and use to ensure proper function and safety.

2. SAFETY INFORMATION

To prevent injury or damage to the product, observe the following safety precautions:

- Ensure all electrical connections are made by a qualified professional.
- Keep children and pets away from the blinds during operation.
- Do not attempt to disassemble or repair the motor or remote control.
- Use only the specified power supply.
- Avoid exposing the blinds to excessive moisture or direct sunlight for prolonged periods.

3. PACKAGE CONTENTS

Verify that all components are present before beginning installation:

- One set of motorized zebra blinds (motor assembled inside the tube, dust cover)
- One remote controller
- One set of installation accessories
- Installation manual (this document)

4. INSTALLATION

4.1. Installation Overview

Proper installation is crucial for the optimal performance of your motorized blinds. Choose between inside or outside mounting based on your window frame and aesthetic preference.



Figure 1: Internal and External Installation Measurement Guide

4.2. Mounting Styles

- **Internal Installation:** For window frames with a depth greater than 4 inches (10 cm). Customized width = window frame net width - 0.5 cm (for security gap). Customized height = window height.
- **External Installation:** Customized width = window frame width + 15 cm. Customized height = window height + 20 cm.

5. PRODUCT FEATURES

5.1. Material and Design

The TIPIACE Zebra Blinds are constructed from durable polyester fabric, offering 90% light blocking capability. They provide thermal insulation, UV protection, and noise abatement. The fabric is water-proof and easily washable, making it suitable for various rooms including bedrooms, offices, kitchens, and bathrooms.

Three-way Lighting Regulation

Light Blocking
10%

Fully Open



Mute Control System

Light Blocking
40%

Half-closed



**Dimmed strong lighting
and no glaring**

Light Blocking
90%

Fully Closed



**Strong lighting blocked for
comfortable sleeping**

Figure 2: Zebra Blind Accessories Diagram

5.2. Motor and Control System

Equipped with a premium, noise-free motor (35dB), these blinds feature an aluminum alloy case and robust thermal design. The motor allows for 5 stopping positions (0-25%, 50%, 75%, 100%). The patented telescopic bearing design of the brackets ensures strong, durable, and easy installation, complemented by a decorative cap for an elegant aesthetic.



Figure 3: Hard-Wired Motor and Control System Overview

5.3. Light Regulation

The dual-layer design allows for three-way lighting regulation:

- **Light Blocking 10% (Fully Open):** Allows maximum light.
- **Light Blocking 40% (Half-closed):** Dims strong lighting and reduces glare.
- **Light Blocking 90% (Fully Closed):** Blocks strong lighting for comfortable sleeping or privacy.

Zebra Blind Accessories

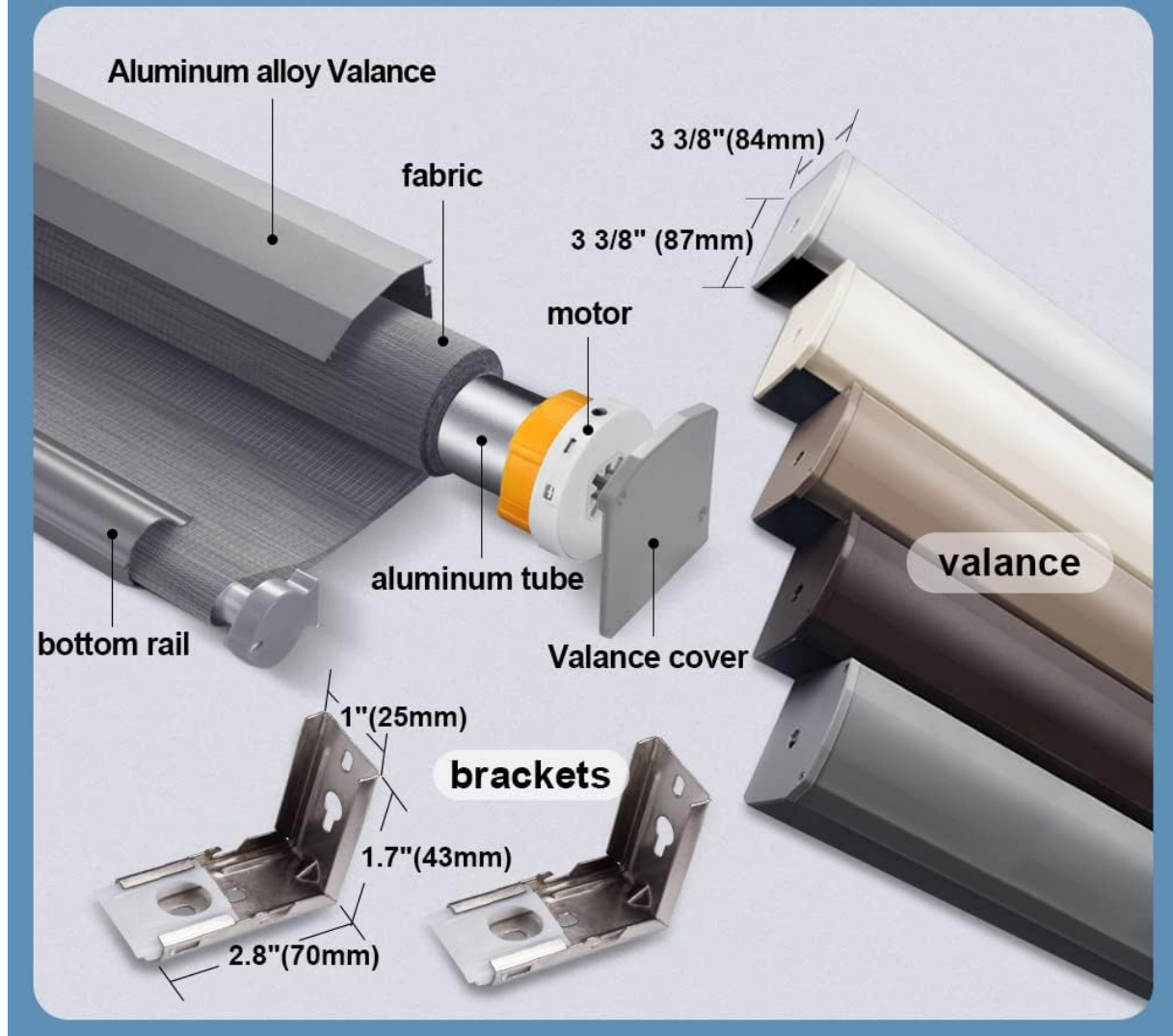

Figure 4: Three-way Lighting Regulation

6. OPERATION

6.1. Remote Control Functions

The included 2-channel remote controller can operate up to 2 blinds independently or control up to 999 blinds synchronously. The remote features Up, Pause, and Down buttons, along with pre-set position buttons for 25%, 50%, and 75% closure.

Video 1: Motorized Roller Blinds - Remote Control, Motor Teaching, Reversing, and Auto-Stop Position Setting. This video demonstrates how to use the remote control, teach the motor, reverse motor direction if needed, and set the upper and lower auto-stop positions for your blinds.

6.2. Smart Home Integration

For enhanced control, these blinds are compatible with Alexa and Google Home via a smart hub (e.g., Bond's hub). This allows for control through mobile applications and smart speakers, enabling features like time scheduling.

7. MAINTENANCE

To clean your TIPIACE Zebra Blinds, use a spot clean only method. Avoid harsh chemicals or abrasive materials that could damage the fabric or motor components.

8. TROUBLESHOOTING

If you encounter any issues with your blinds, please refer to the following common solutions:

- **Blinds not responding to remote:** Check the remote control battery (CR2032). Ensure the remote is paired correctly with the motor.
- **Motor direction is incorrect:** Follow the motor reversing instructions provided in the operation section (refer to Video 1).
- **Blinds not stopping at desired positions:** Re-set the auto-stop positions as described in the operation section (refer to Video 1).
- For further assistance, please contact customer support.

9. SPECIFICATIONS

Feature	Detail
Brand	TIPIACE
Model	HD-162
Material	Polyester, Polyester Blend
Product Dimensions	30"L x 4"W
Recommended Uses	Indoor
Operation Mode	Automatic
Additional Features	Light Filtering
Closure Type	Motorized
Mounting Type	Inside Mount, Outside Mount
Water Resistance Level	Water Resistant
Control Type	Up and down
Item Weight	4 Pounds
Product Care Instructions	Spot Clean Only
Room Type	Bedroom
Included Components	User Manual
Manufacturer	ZHISHANG
UPC	739319486488
ASIN	B0BG358HSP
Pattern	Solid

10. WARRANTY AND SUPPORT

Your TIPIACE Hard-Wired Motorized Zebra Blinds come with a 2-year manufacturer warranty. For warranty claims, technical support, or any questions, please contact TIPIACE customer service through the retailer where the product was purchased or visit the official TIPIACE website.