



[Manuals.plus](#) /

› [HCDC](#) /

› [HCDC DC12V 10Amp Forward and Reverse Relay Module \(HD044 Series\) Instruction Manual](#)

HCDC HD044 Series

HCDC DC12V 10Amp Forward and Reverse Relay Module

Model: HD044 Series

[Introduction](#) [Features](#) [Setup & Installation](#) [Operation](#) [Wiring](#)
[Diagrams](#) [Specifications](#) [Troubleshooting](#) [Maintenance](#) [Warranty & Support](#)

1. INTRODUCTION

This instruction manual provides detailed information for the safe and efficient use of the HCDC DC12V 10Amp Forward and Reverse Relay Module (HD044 Series). This module is designed to control the direction of 2-wire DC motors and linear actuators, enabling forward and reverse motion for various applications. Please read this manual thoroughly before installation and operation to ensure proper functionality and to prevent damage to the device or connected equipment.



Figure 1: The HCDC HD044 Series Relay Module. This image shows the compact black module with its green 'REV' (Reverse) and red 'FWD' (Forward) push buttons, along with indicator LEDs and screw terminal block.

2. KEY FEATURES

- **Motor Reversing Capability:** Powers any 2-wire reversing DC motor equipment.
- **Integrated Control Buttons:** Features built-in Forward (FWD) and Reverse (REV) momentary buttons for direct control.
- **External Switch Support:** Compatible with external momentary-action (self-resetting) or alternate-action (self-holding) switches.
- **Compact Design:** Housed in a compact plastic case with screw terminal blocks for easy mounting and connection.
- **Status Indicators:** Includes a power indicator LED and separate LEDs for forward (red) and reverse (green) status.
- **Electrical Ratings:** Rated current of 10 Amps, operating voltage range of 10V to 15V DC.

3. SETUP AND INSTALLATION

3.1 Unpacking and Inspection

Carefully remove the relay module from its packaging. Inspect the device for any visible damage that may have occurred during shipping. If any damage is found, do not proceed with installation and contact customer support.

3.2 Mounting

The module features mounting tabs for secure installation. Choose a dry, stable location away from excessive heat, moisture, and direct sunlight. Ensure adequate ventilation around the module.

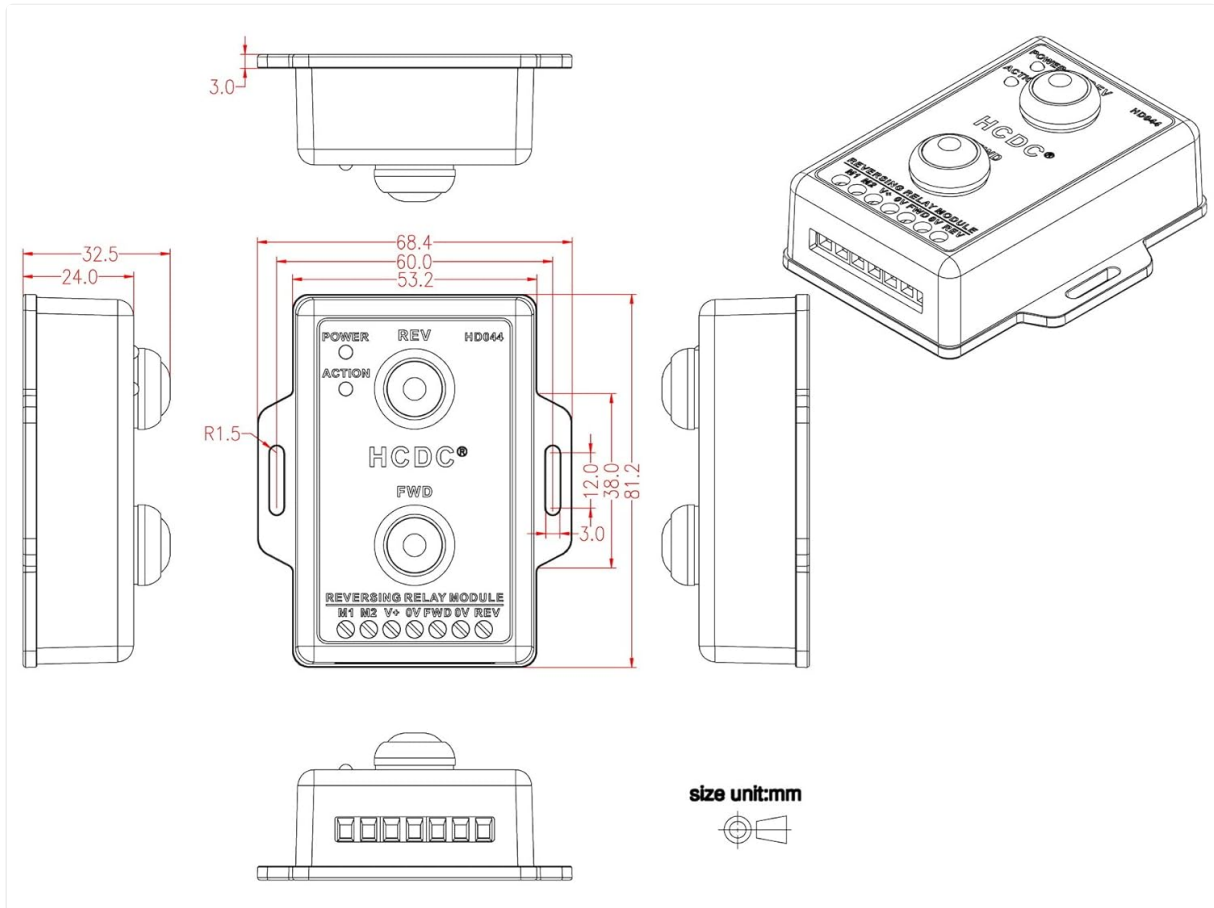

Figure 2: Dimensions of the HCDC HD044 Series Relay Module. This image shows the physical dimensions of the module in millimeters, including length, width, and height, which are essential for proper mounting and integration into an enclosure.

3.3 Power Requirements

The module operates on a DC voltage between 10V and 15V. Ensure your power supply meets these requirements and can provide sufficient current for both the module and the connected motor (up to 10 Amps).

4. OPERATING INSTRUCTIONS

4.1 Basic Operation (Using Onboard Buttons)

1. Connect the module to a DC power source and a 2-wire DC motor as per the wiring diagrams in Section 5.
2. The **POWER** indicator LED will illuminate when power is supplied.
3. Press the **FWD** (Forward) button: The motor will move in one direction, and the red **FWD** status LED will light up. Release the button to stop the motor.

- Press the **REV** (Reverse) button: The motor will move in the opposite direction, and the green **REV** status LED will light up. Release the button to stop the motor.

Note: The onboard buttons are momentary-action. The motor will only operate while the button is pressed.

4.2 Operation with External Switches

The module supports external momentary-action (self-resetting) or alternate-action (self-holding) switches. Refer to Section 5 for specific wiring configurations.

- **Momentary-action (Self-resetting) Switch:** When the external switch is pressed, the motor operates. When the switch is released, the motor stops.
- **Alternate-action (Self-holding) Switch:** Pressing the switch once will start the motor, and it will continue to run until the switch is pressed again to stop it.

5. WIRING DIAGRAMS

Proper wiring is crucial for the correct and safe operation of the relay module. Always ensure power is disconnected before making any wiring changes. The terminal block is clearly labeled for easy connection.

M1, M2: Motor connections.

V+, 0V: DC Power input (V+ for positive, 0V for negative).

FWD, REV: External switch connections for Forward and Reverse control.

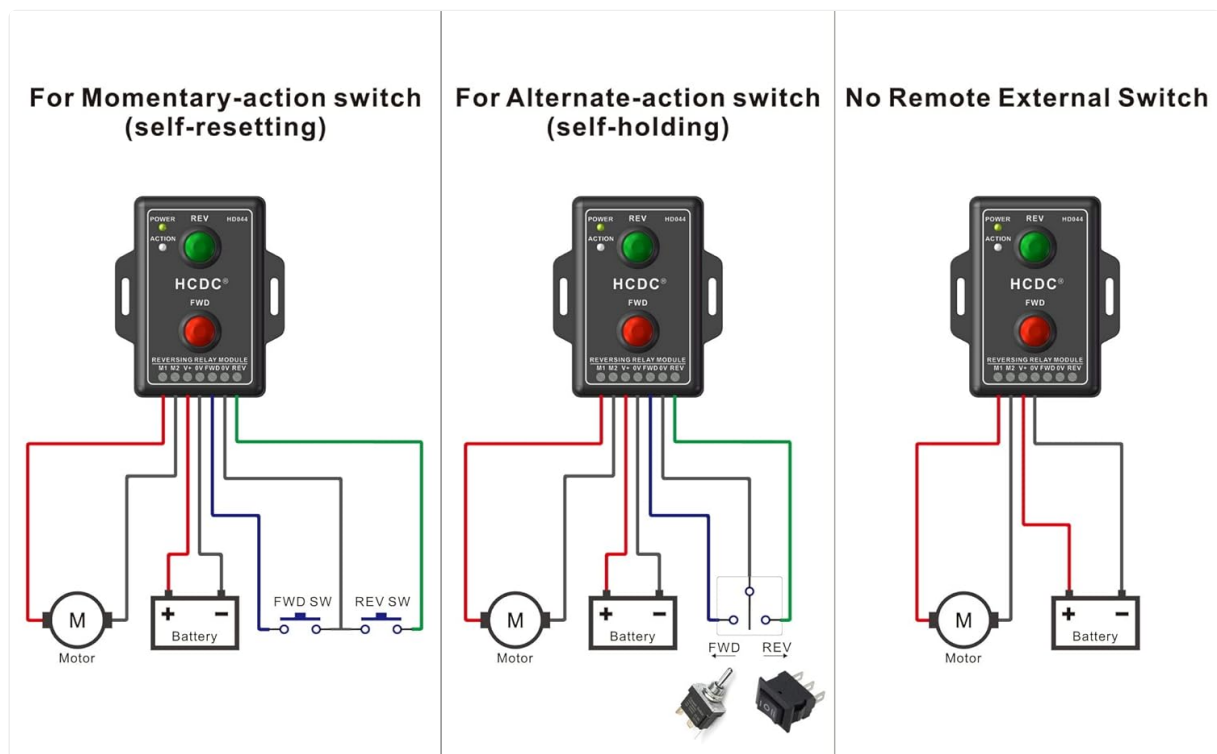

Figure 3: Comprehensive wiring diagrams for the HCDC HD044 Series Relay Module. This image illustrates three common wiring configurations: using a momentary-action switch, an alternate-action switch, and operating without any external switches, relying solely on the onboard buttons. Each diagram shows connections for the motor, battery, and external switches (if applicable).

5.1 Wiring for Momentary-Action External Switch (Self-Resetting)

Connect the external momentary switches between the FWD/REV terminals and the positive power supply (V+). When the FWD switch is pressed, the motor runs forward. When the REV switch is pressed, the motor runs in reverse. Releasing the switch stops the motor.

5.2 Wiring for Alternate-Action External Switch (Self-Holding)

Connect the external alternate-action switches between the FWD/REV terminals and the positive power supply (V+). Pressing the FWD switch once will start the motor in forward motion, and it will continue until the FWD switch is pressed again. The same applies to the REV switch for reverse motion.

5.3 Wiring without External Switch (Onboard Buttons Only)

If no external switches are desired, simply connect the motor to M1/M2 and the power supply to V+/0V. Control will be exclusively via the onboard FWD and REV buttons.

6. TECHNICAL SPECIFICATIONS

Parameter	Value
Model Number	HD044 Series
Operating Voltage	10V - 15V DC
Rated Current	10 Amps
Contact Type	Normally Open
Connector Type	Screw Terminal Block
Mounting Type	Surface Mount
Dimensions (L x W x H)	Approx. 68.4 x 32.5 x 24.0 mm (Refer to Figure 2 for detailed dimensions)
Weight	Approx. 472 g (Package weight)

7. TROUBLESHOOTING

If you encounter issues with your HCDC Relay Module, refer to the following troubleshooting guide:

Problem	Possible Cause	Solution
Module has no power (POWER LED off)	No power supply, incorrect voltage, or loose connections.	Check power supply (10-15V DC). Verify all power connections (V+, 0V) are secure.
Motor does not move	Incorrect motor wiring, motor fault, insufficient power, or button/switch issue.	Ensure motor is correctly connected to M1/M2. Check motor functionality independently. Verify power supply. Test onboard buttons. If using external switches, check their wiring and functionality.
Motor moves in wrong direction	Motor polarity reversed.	Reverse the motor connections at M1/M2 terminals.

Problem	Possible Cause	Solution
External switch not working	Incorrect wiring for external switch, faulty switch.	Refer to Section 5 for correct external switch wiring. Test the external switch independently.
Module gets hot during operation	Overcurrent, motor drawing too much power.	Ensure motor current draw does not exceed 10 Amps. Check for motor stalls or excessive load.

8. MAINTENANCE

The HCDC Relay Module is designed for reliable operation with minimal maintenance. Follow these guidelines to ensure longevity:

- **Cleaning:** Keep the module clean and free from dust and debris. Use a soft, dry cloth for cleaning. Do not use liquid cleaners or solvents.
- **Environmental Conditions:** Ensure the module is operated within its specified temperature and humidity ranges. Avoid exposure to corrosive gases or liquids.
- **Connection Checks:** Periodically inspect all wiring connections to ensure they are secure and free from corrosion.

9. WARRANTY AND SUPPORT

For warranty information or technical support, please refer to the retailer or manufacturer's official website where the product was purchased. Keep your purchase receipt as proof of purchase.

For further assistance, please contact HCDC customer support through their official channels.