

CNCTOPBAOS Rattm 72V 8.3A

CNCTOPBAOS 600W 72V DC Switching Power Supply User Manual

Model: Rattm 72V 8.3A | Brand: CNCTOPBAOS

1. INTRODUCTION

This manual provides essential information for the safe and efficient operation of your CNCTOPBAOS 600W 72V DC Switching Power Supply. Please read these instructions carefully before installation and use. Keep this manual for future reference.

2. SAFETY INSTRUCTIONS

- **Input Voltage Selection:** Before connecting the power supply, ensure the input voltage switch (115V/230V) is set correctly for your region's AC supply. Incorrect selection can cause damage to the unit.
- **Professional Installation:** Installation should be performed by qualified personnel to prevent electric shock or damage.
- **Ventilation:** Ensure adequate ventilation around the power supply. Do not block cooling vents.
- **Grounding:** Always connect the ground wire properly to prevent electrical hazards.
- **Overload Protection:** Do not exceed the maximum output power (600W) or current (8.3A) to avoid damage and ensure safety.
- **Moisture and Dust:** Keep the unit away from moisture, water, and excessive dust.

Warning: This power supply contains high voltage. Do not open the casing unless you are a qualified technician.

3. PRODUCT OVERVIEW

The CNCTOPBAOS 600W 72V DC Switching Power Supply is a universal AC to DC converter designed for various applications requiring a stable 72V DC output. It features a robust design with efficient heat dissipation.

Key Features:

- Universal AC input (110VAC/220VAC selectable).
- Adjustable output voltage range (0-100%).
- Built-in cooling fan for efficient heat dissipation.
- High efficiency (>85%).
- Overload, over-voltage, and short-circuit protection.

Components and Connections:

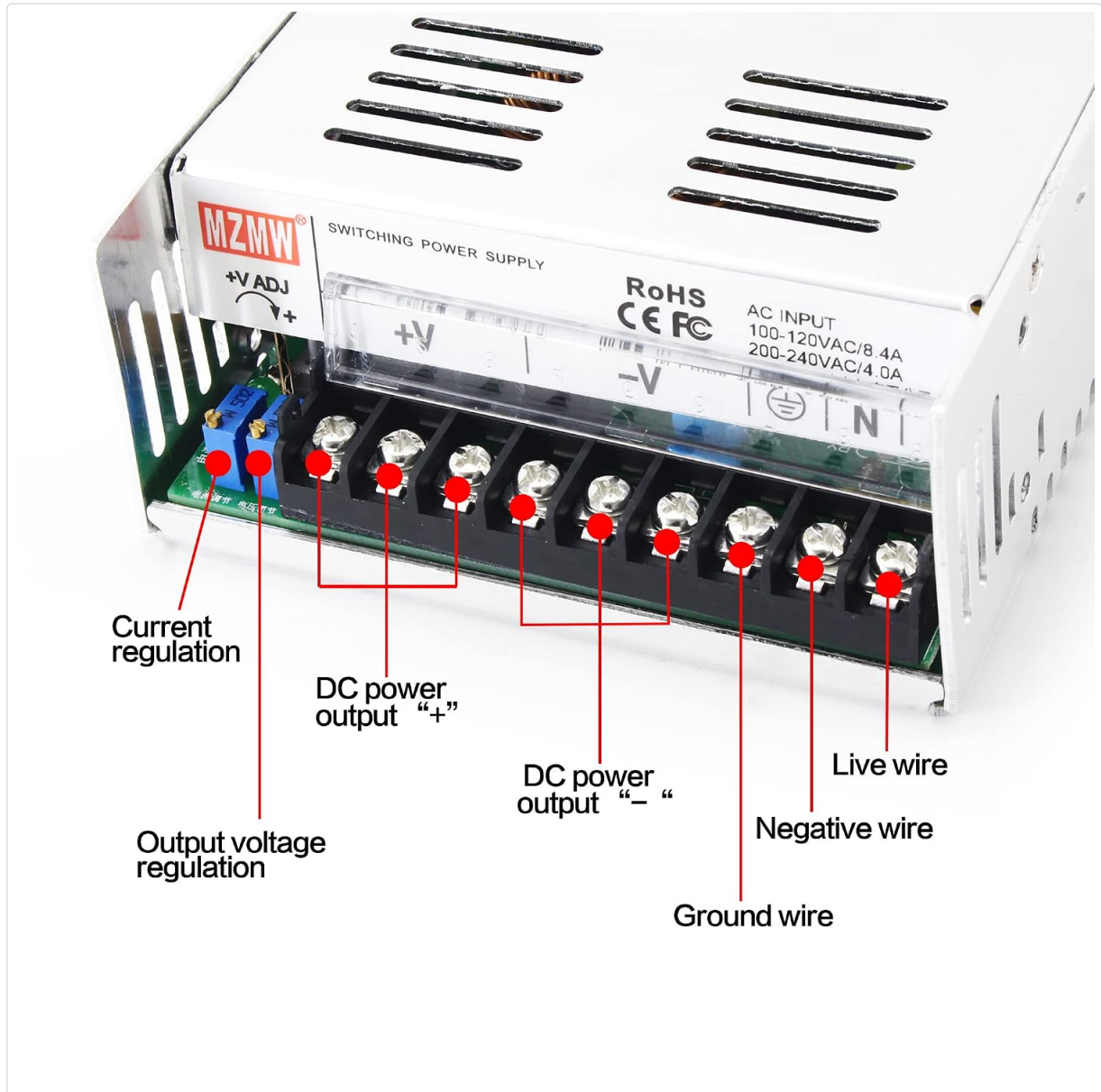

Figure 3.1: Connection terminals. This image illustrates the AC input terminals (Live, Neutral, Ground), DC output terminals (+V, -V), and adjustment potentiometers for output voltage and current regulation.

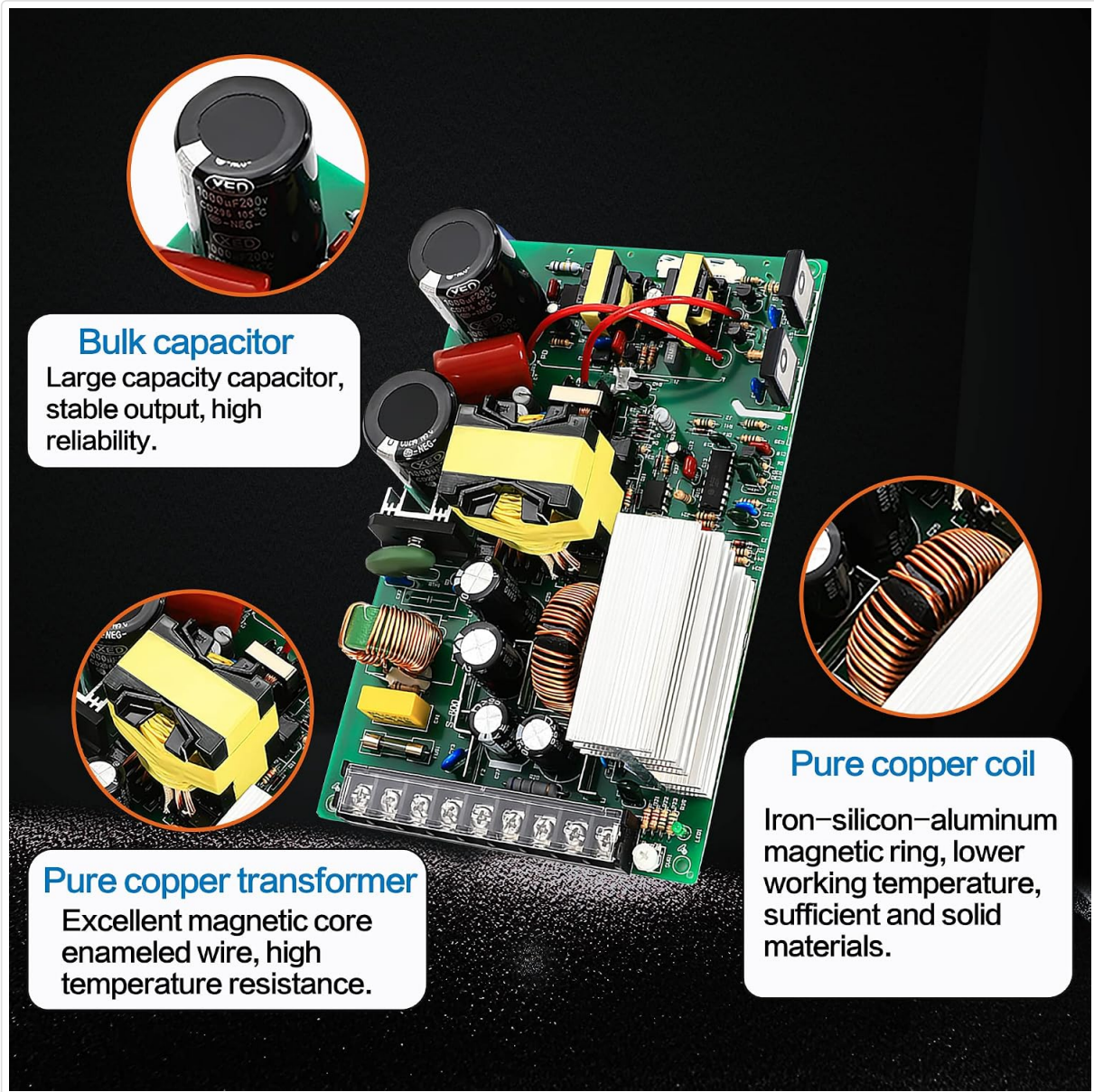

Figure 3.2: Internal components. Key components like the large capacity capacitor, pure copper transformer, and pure copper coil are highlighted, indicating stable output and high reliability.

Efficient and stable heat dissipation

The fan quickly dissipates heat, protecting the internal components of the switching power supply



Figure 3.3: Efficient heat dissipation. The image shows the power supply's built-in cooling fan and numerous ventilation holes, which are crucial for maintaining optimal operating temperature.

4. SPECIFICATIONS

Parameter	Value
Model	Rattm 72V 8.3A
Input Voltage Range	100-120V AC or 200-240V AC (selectable by switch)
Output Voltage	0-72V DC (adjustable)
Output Current	8.3A
Output Power	600W
Efficiency	>85%
Voltage Accuracy	±1%
Load Stability	<±0.5%

Parameter	Value
Line Regulation	$\pm 0.5\%$
Product Dimensions	215 x 115 x 50 mm (8.46 x 4.52 x 1.96 inches)
Product Weight	2.05 pounds
Manufacturer	Changzhou Rattm Motor Co.,Ltd

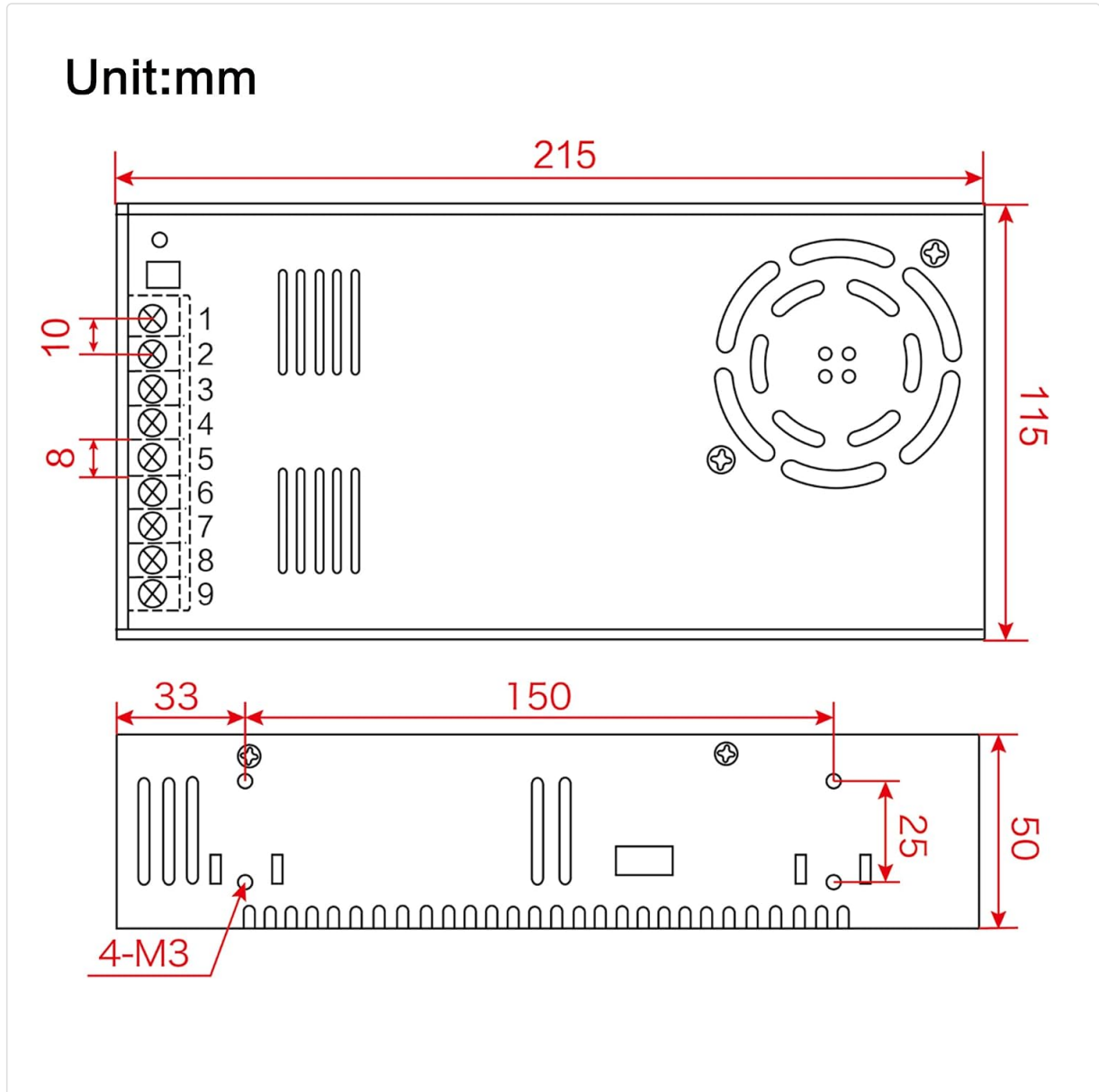

Figure 4.1: Product dimensions. This diagram provides precise measurements of the power supply unit, useful for installation planning.

5. SETUP AND INSTALLATION

Step 1: Select Input Voltage

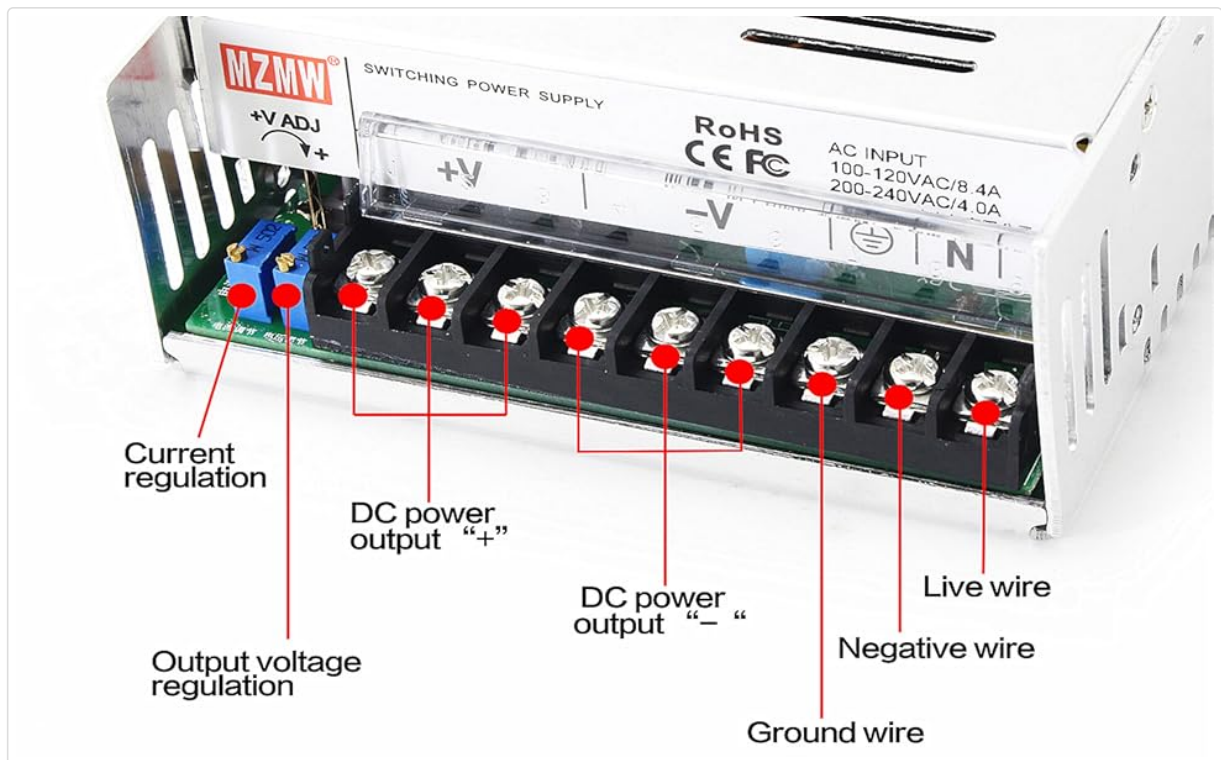

Figure 5.1: Input voltage selection switch. This switch must be set to either 115V or 230V to match your local AC power supply before connecting the unit.

Locate the red switch on the side of the power supply. Set it to **115V** for 100-120V AC input or **230V** for 200-240V AC input. **Failure to select the correct voltage will damage the unit.**

Step 2: Wiring Connections

Refer to Figure 3.1 for terminal identification. Ensure all connections are secure and correctly polarized.

1. **AC Input:** Connect your AC power source to the L (Live), N (Neutral), and Ground terminals.
2. **DC Output:** Connect your load to the +V (positive) and -V (negative) terminals. Ensure correct polarity for your device.

Step 3: Mounting

Mount the power supply in a location that allows for adequate airflow and heat dissipation. Use appropriate screws and ensure the unit is stable.

6. OPERATING INSTRUCTIONS

Adjusting Output Voltage

The output voltage can be adjusted using the potentiometer labeled "+V ADJ" (Output voltage regulation) on the terminal block (refer to Figure 3.1). Use a small screwdriver to carefully turn the potentiometer clockwise to increase voltage or counter-clockwise to decrease it. Monitor the output voltage with a multimeter during adjustment.

Powering On/Off

Once all connections are secure and the input voltage is correctly selected, apply AC power. The unit will power on. To power off, disconnect the AC input.

7. MAINTENANCE

- **Cleaning:** Periodically clean the exterior of the power supply and ensure ventilation openings are free

from dust and debris. Use a soft, dry cloth. Do not use liquid cleaners.

- **Ventilation:** Regularly check that the cooling fan is operating and that airflow is not obstructed.
- **Connection Check:** Periodically inspect all wiring connections to ensure they remain tight and secure.

8. TROUBLESHOOTING

- **No Output Voltage:**

- Check AC input power.
- Verify the input voltage switch (115V/230V) is set correctly.
- Inspect wiring for loose connections or damage.

- **Output Voltage Unstable or Incorrect:**

- Ensure the load does not exceed the power supply's capacity (600W, 8.3A).
- Adjust the "+V ADJ" potentiometer carefully.
- Check for proper ventilation; overheating can affect performance.

- **Overheating:**

- Ensure the cooling fan is operational and not obstructed.
- Verify adequate space around the unit for airflow.
- Reduce the load if it is consistently operating at maximum capacity.

If problems persist after following these steps, contact customer support.

9. PRODUCT VIDEO

For a visual overview of the CNCTOPBAOS 600W 72V DC Switching Power Supply, please watch the following video:

Your browser does not support the video tag.

Video: 600W power supply product display. This video provides a visual demonstration and overview of the power supply unit.

10. WARRANTY AND SUPPORT

For warranty information and technical support, please refer to the documentation included with your purchase or contact CNCTOPBAOS customer service directly. Keep your purchase receipt as proof of purchase.