

[Manuals.plus](#) /

› [Brinsea](#) /

› Brinsea TLC-50 Advance Series II Large Bird Brooder Pet Incubator with Nebulizer and Digital Display User Manual

## Brinsea USHD4111C

# Brinsea TLC-50 Advance Series II User Manual

Large Bird Brooder Pet Incubator with Nebulizer and Digital Display

## 1. INTRODUCTION

---

The Brinsea TLC-50 Advance Series II is a state-of-the-art intensive care unit (ICU) designed to provide an optimal environment for the care and recovery of small animals. This multi-purpose incubator is ideal for newly hatched exotic chicks, newborn puppies and kittens, and sick, injured, or orphaned small animals. It offers precise control over temperature and humidity, ensuring a stable and hygienic space for vulnerable creatures. This manual provides essential information for the safe and effective operation, maintenance, and troubleshooting of your Brinsea TLC-50 Advance Series II incubator.

# MAIN FEATURES

- Digital display and precision controls
- Nebulizer solution holder
- Quiet fan with adjustable speed to minimize noise and disturbance
- Clear door & internal light for easy observation
- Twin stage air filtration
- Adjustable fresh air vent



Figure 1: The Brinsea TLC-50 Advance Series II incubator in use, providing a safe environment for a hedgehog.

## 2. WHAT'S IN THE BOX

Upon unpacking, please verify that all components listed below are present and undamaged. If any items are missing or damaged, contact Brinsea customer support immediately.

- Brooder/ICU top assembly (with 3 air filters fitted)
- 1 Cabinet base
- Cabinet door
- Hinge socket
- Fastener and tool kit (nuts, screws, washers, wrench)
- Mains power cable with US plug
- Nebulizer solution holder with tubing
- Water funnel
- White evaporation block

# DIMENSIONS

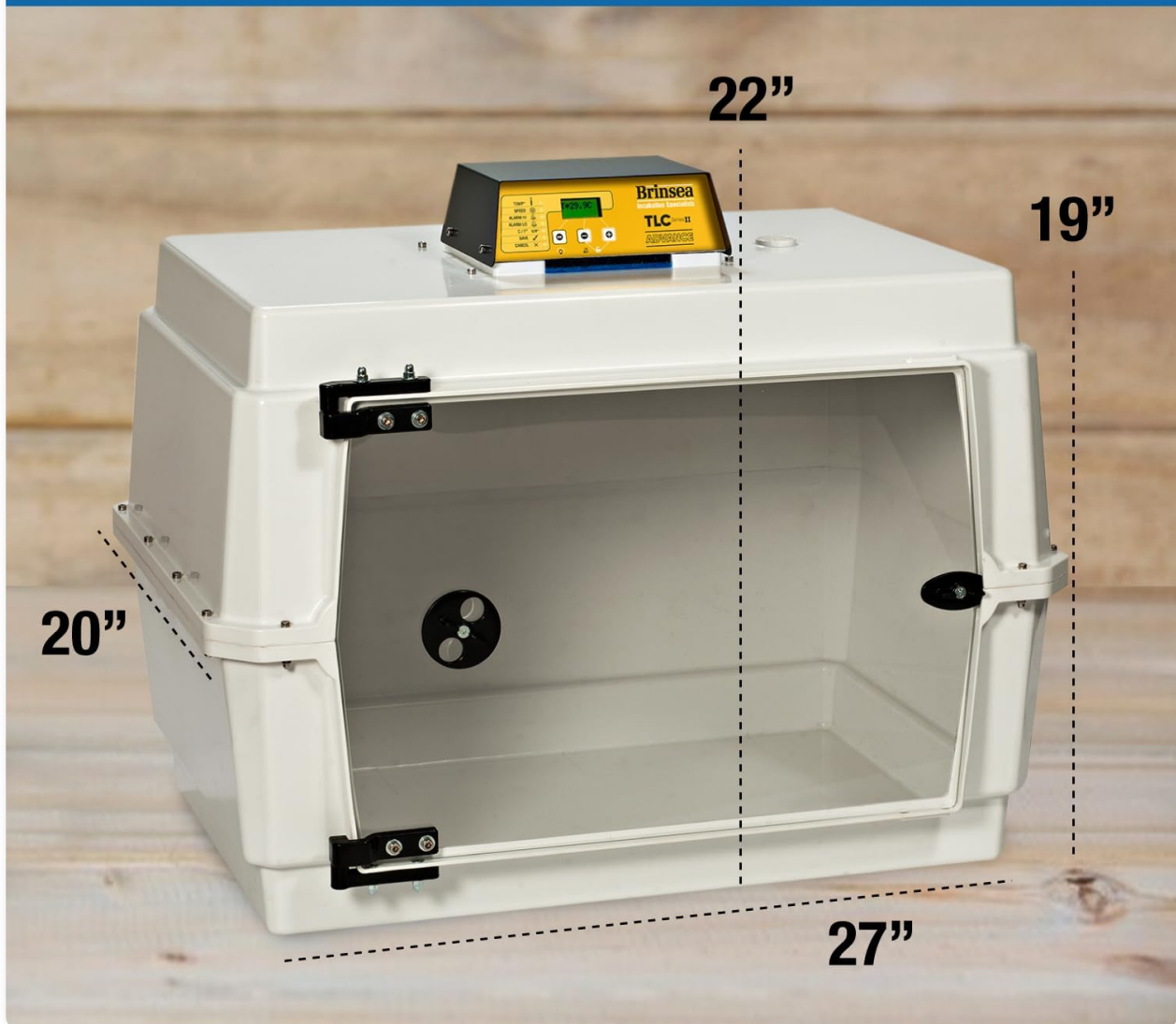

Figure 2: All parts included in the Brinsea TLC-50 Advance Series II package.

## 3. SETUP

Follow these steps to assemble and prepare your incubator for first use:

1. **Unpack Components:** Carefully remove all items from the packaging. Retain the packaging for future storage or transport.
2. **Assemble Cabinet:** Place the brooder/ICU top assembly onto the cabinet base. Secure the cabinet door using the provided nuts, screws, and washers. Ensure all connections are firm and stable.
3. **Install Evaporation Block:** Place the white evaporation block into the clear water pan provided. This is crucial for humidity control.
4. **Attach Nebulizer Holder:** Securely attach the nebulizer solution holder to the designated port on the side of the unit. Connect the tubing as shown in the diagram. Note that the nebulizer pump is not

supplied and must be acquired separately.

5. **Connect Power:** Plug the mains power cable into the unit's power input, then into a suitable electrical outlet.
6. **Add Water for Humidity:** Use the provided water funnel to add distilled water to the external water reservoir. This system allows for convenient top-up without disturbing the animals inside.

## EXCELLENT TEMPERATURE STABILITY



- Double-walled cabinet for heat and sound insulation.
- Positive pressure fan-assisted airflow:
  - Even heating
  - Optimal comfort of the animals
- Water reservoir with external top up:
  - No need to open and disturb the animals
  - No temperature fluctuation

Figure 3: Adding water to the external reservoir for increased humidity capability.

## 4. OPERATING INSTRUCTIONS

The Brinsea TLC-50 Advance Series II features precise digital controls for optimal environmental management.

### 4.1. Control Panel Overview

The control panel provides digital readouts and buttons for adjusting settings.

# INCREASED HUMIDITY CAPABILITY

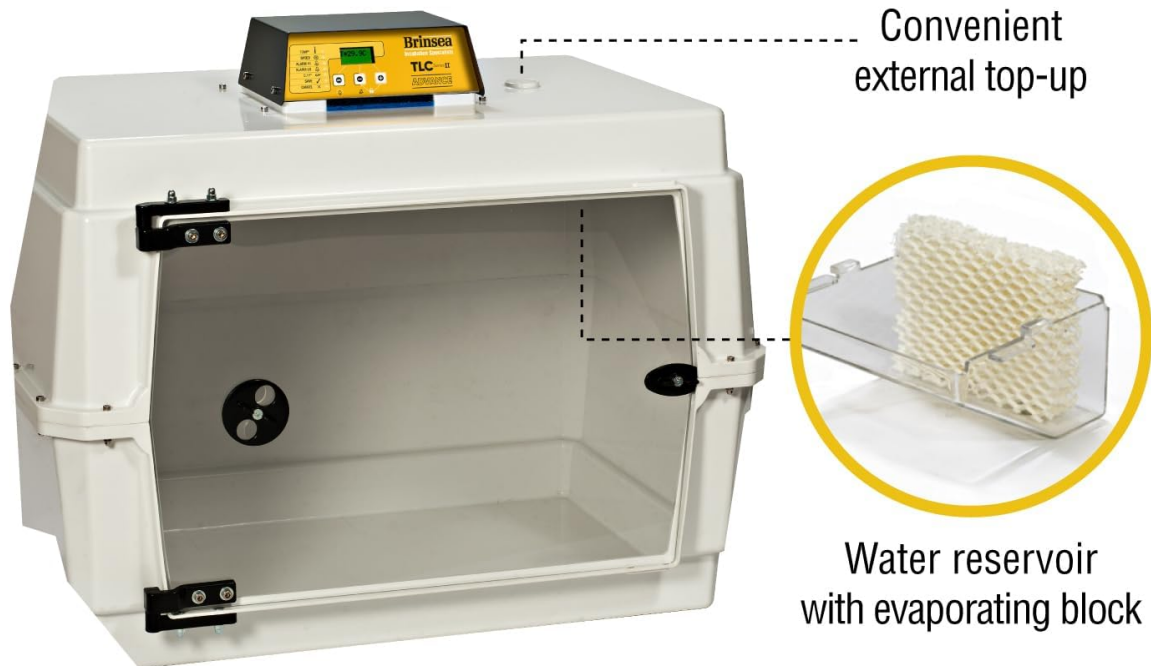

- **Increased Humidity Capability:**
  - Water reservoir with evaporating block to increase humidity and reduce the risk of dehydration
  - Removable for easy cleaning
  - Convenient external top-up

Figure 4: Detailed view of the precision control panel.

- **Digital Display:** Shows current temperature (in °C or °F) and humidity levels.
- **OK Button:** Switches the internal LED light on/off.
- **Minus (-) and Plus (+) Buttons:** Used to adjust temperature, high/low alarms, and navigate menus. Pressing both simultaneously unlocks the menu.
- **Alarm Indicators:** Visual alerts for high and low temperature conditions.

## 4.2. Temperature Control

The unit provides digital control and read-out of temperature. It is preset to 86°F (30°C).

- To adjust the temperature, use the - and + buttons.
- High and low temperature alarms are included, along with a patented room temperature alarm, to ensure optimal safety.

## 4.3. Humidity Control

The incubator provides a digital display of the humidity level achieved in the chamber. Increased humidity capability is provided by an improved door fit and increased evaporating surface.

- Ensure the water reservoir is adequately filled to maintain desired humidity levels.

#### 4.4. Airflow and Ventilation

Airflow in the TLC-50 Advance Series II has been optimized for consistent heat distribution and gentle airspeeds to prevent disturbance to animals.

- The variable fan speed allows adjustment for stress-sensitive animals.
- An adjustable fresh air vent is included for optimal air exchange.

## DURABLE & EASY TO CLEAN

- Tough ABS plastic construction

- Removable clear door and base for easy cleaning



- Smooth mirror finish Biomaster protected for easy maintenance and longer life



Figure 5: Illustration of excellent temperature stability through optimized airflow.

#### 4.5. Nebulizer Functionality

The nebulizer solution holder allows for convenient administration of medication. A nebulizer pump is required and sold separately.

### 5. MAINTENANCE

Regular cleaning and maintenance are essential for the health of your animals and the longevity of the incubator.

- **Easy Cleaning Design:** The lower half of the cabinet and the door are removable, allowing them to be scrubbed and immersed for thorough cleaning.
- **Biomaster Protection:** The incubator is constructed from robust plastics protected by Polygiene Biomaster, which inhibits the growth of harmful bacteria, making cleaning easier and improving hygiene.
- **Water Pan Cleaning:** The water reservoir with the evaporating block is removable for easy cleaning.

## PARTS INCLUDED



- 100-liter cabinet
- Nebulizer solution holder
- Power cord
- Clear door
- Fastener kit

Figure 6: The incubator's design emphasizes durability and ease of cleaning.

## 6. TROUBLESHOOTING

This section addresses common issues you might encounter with your Brinsea TLC-50 Advance Series II incubator.

- **Temperature Fluctuations:** Ensure the unit is placed in a stable environment away from direct sunlight or drafts. Check that the water reservoir is filled, as proper humidity aids temperature stability. Verify the fan is operating correctly.
- **Humidity Issues:** If humidity is too low, ensure the water pan is full and the evaporation block is correctly placed. If humidity is too high, ensure the fresh air vent is open and the room humidity is not

excessively high.

- **Alarms Sounding:** Check the digital display for the specific alarm (high/low temperature, room temperature). Adjust settings or environmental conditions as needed. Press the '-' button to silence alarms.
- **Unit Not Powering On:** Verify the power cable is securely connected to both the unit and the electrical outlet. Check the power source.

For issues not covered here, please refer to the full instruction manual or contact Brinsea customer support.

## 7. SPECIFICATIONS

Feature	Detail
Model Name	Brinsea TLC-50 Advance Series II Large Bird Brooder Pet Incubator with nebulizer
Item Model Number	USHD4111C
Capacity	100 Liters
Item Dimensions (LxWxH)	27 x 20 x 21 inches
Item Weight	24 pounds
Material	Plastic (Biomaster protected)
Color	Off White
Style	Nebulizer & Digital Temperature Control
Target Audience	Birds, Cats, Dogs, Rabbits, Small Animals
Specific Uses	Indoor, Transport

# WHY BUY BRINSEA?

## Innovation you can trust, Service you can rely on



**LEADING  
TECHNOLOGY FOR  
OVER 45 YEARS**



**EXPERT  
CUSTOMER CARE  
& SUPPORT**



**TRUSTED  
IN OVER  
65 COUNTRIES**

**Brinsea**  
**Incubation Specialists**



Figure 7: Product dimensions for the Brinsea TLC-50 Advance Series II.

## 8. WARRANTY & SUPPORT

Brinsea Products stands behind the quality of its incubators.

- **Warranty:** The Brinsea TLC-50 Advance Series II comes with a full 3-year manufacturer's warranty. This warranty is subject to registration within 30 days of purchase. Please refer to the warranty card included in your package for full terms and conditions.
- **Manufacturer:** Brinsea Products
- **Customer Support:** For technical assistance, spare parts, or warranty claims, please contact Brinsea Products directly. Contact information can be found on the Brinsea website or in the documentation provided with your product.

For more information, visit the official [Brinsea Store on Amazon](#).