

Bokaiya 33x19 Kitchen Sink Workstation

Bokaiya 33 Inch Black Undermount Kitchen Sink Workstation

INSTRUCTION MANUAL

Model: 33x19 Kitchen Sink Workstation

1. INTRODUCTION

This manual provides detailed instructions for the installation, operation, and maintenance of your Bokaiya 33 Inch Black Undermount Kitchen Sink Workstation. Crafted from durable T304 stainless steel with a 16-gauge thickness, this sink is designed for longevity and functionality. The innovative workstation design, coupled with a NANO brushed finish, enhances your kitchen experience by providing a versatile and easy-to-maintain workspace.

Please read all instructions carefully before beginning installation or use to ensure proper function and safety.

2. PACKAGE CONTENTS

Verify that all components listed below are included in your package:

- Bokaiya 33 Inch Black Undermount Kitchen Sink
- Multi-functional Stainless Steel Dish Grid
- 3-Piece Basket Strainer Set
- Solid Wood Cutting Board
- Deep Stainless Steel Colander
- Dish-Drying Roll-Up Rack
- Cutout Template

- Mounting Clips



An overhead view of the Bokaiya 33-inch black undermount kitchen sink, showcasing its workstation design with a wooden cutting board, a roll-up drying rack, a stainless steel colander, and a bottom grid. All included accessories are displayed below the sink.

3. SPECIFICATIONS

Feature	Specification
Exterior Dimensions	33"L x 19"W x 10"D
Interior Dimensions	31"L x 17"W x 10"D
Material	T304 Stainless Steel, 16 Gauge
Installation Type	Undermount
Drain Opening	Standard 3-1/2"
Finish	Gunmetal Black NANO brushed
Sound Dampening	Thicker & softer Rubber Pads

Complimentary Accessories

Wood Cutting Board**Dish Drying Roll-up Rack****Basket Strainer Drain****Stainless Steel Colander****Stainless Steel Dish Grid**

A technical diagram detailing the exterior and interior dimensions of the Bokaiya 33"L x 19"W x 10"D kitchen sink, including the standard 3-1/2" drain opening and recommended minimum cabinet size.

4. SETUP AND INSTALLATION

This sink is designed for undermount installation. Professional installation is recommended to ensure proper fit and function. Always consult local plumbing codes before installation.

4.1 Pre-Installation Checklist

- Ensure countertop opening matches the provided cutout template.
- Verify all plumbing connections are accessible and in good condition.
- Gather necessary tools: sealant, drill, clamps, screwdriver, safety glasses.

4.2 Installation Steps (Overview)

1. **Prepare Countertop:** Use the provided cutout template to mark and cut the opening in your countertop. Ensure edges are smooth and clean.

2. **Apply Sealant:** Apply a continuous bead of silicone sealant around the perimeter of the sink opening on the underside of the countertop.
3. **Position Sink:** Carefully lift the sink and align it with the countertop opening from below. Press firmly to ensure good contact with the sealant.
4. **Secure with Clips:** Attach the mounting clips to the underside of the countertop and tighten them evenly to secure the sink in place. Do not overtighten.
5. **Connect Plumbing:** Install the drain assembly, faucet, and any other plumbing fixtures according to their respective manufacturer's instructions.
6. **Test for Leaks:** Once all connections are made, run water into the sink and check thoroughly for any leaks.



The Bokaiya black undermount kitchen sink, empty and installed in a white countertop, highlighting its deep single bowl design and sleek appearance.

5. OPERATING INSTRUCTIONS (WORKSTATION FEATURES)

Your Bokaiya kitchen sink features an integrated workstation ledge, allowing you to slide various accessories across the sink for enhanced functionality.

5.1 Using the Integrated Ledge

The workstation ledge is designed to hold the included cutting board, colander, and roll-up drying rack. Simply place the accessory onto the ledge, and it will securely rest above the sink basin, allowing for easy food preparation, rinsing, or drying.

- **Cutting Board:** Position the solid wood cutting board on the ledge for convenient food preparation directly over the sink, allowing scraps to fall directly into the basin.
- **Stainless Steel Colander:** Place the deep colander on the ledge for rinsing fruits, vegetables, or draining pasta.
- **Dish-Drying Roll-Up Rack:** Unroll the drying rack across the sink for air-drying dishes, glasses, or utensils. It can also serve as a trivet for hot pots and pans.
- **Dish Grid:** The stainless steel dish grid rests at the bottom of the sink, protecting the surface from scratches and allowing water to drain freely.



The Bokaiya workstation sink integrated into a kitchen counter, featuring a wooden cutting board and a roll-up drying rack positioned on the integrated ledges, demonstrating its functional design for food preparation and dish drying.



A top-down view of the Bokaiya black undermount kitchen sink, showing the protective stainless steel grid at the bottom of the basin, designed to prevent scratches and allow for better drainage.

5.2 Video Demonstration: Workstation Features

Your browser does not support the video tag.

A video demonstrating the practical use of the Bokaiya workstation sink, showcasing how the colander, drying rack, and cutting board integrate with the sink's ledges for efficient food preparation and cleanup.

6. MAINTENANCE

Proper care and maintenance will ensure the longevity and appearance of your Bokaiya kitchen sink.

6.1 Daily Cleaning

- Wipe the sink surface with a soft cloth and mild soap or a non-abrasive cleaner after each use.
- Rinse thoroughly with water and wipe dry to prevent water spots, especially with the NANO brushed finish.
- The NANO finish is designed to repel water and resist stains, making cleaning easier.

6.2 Avoiding Damage

- Avoid using abrasive cleaners, steel wool, or harsh chemicals, as these can damage the finish.
- Do not leave acidic foods (e.g., citrus, vinegar) or strong chemicals on the sink surface for extended periods.
- The included bottom grid helps protect the sink from heavy impacts and scratches.

6.3 Sound Dampening and Condensation

The sink is equipped with thicker rubber pads and an anti-condensation undercoating to minimize noise and prevent moisture buildup in your cabinet.

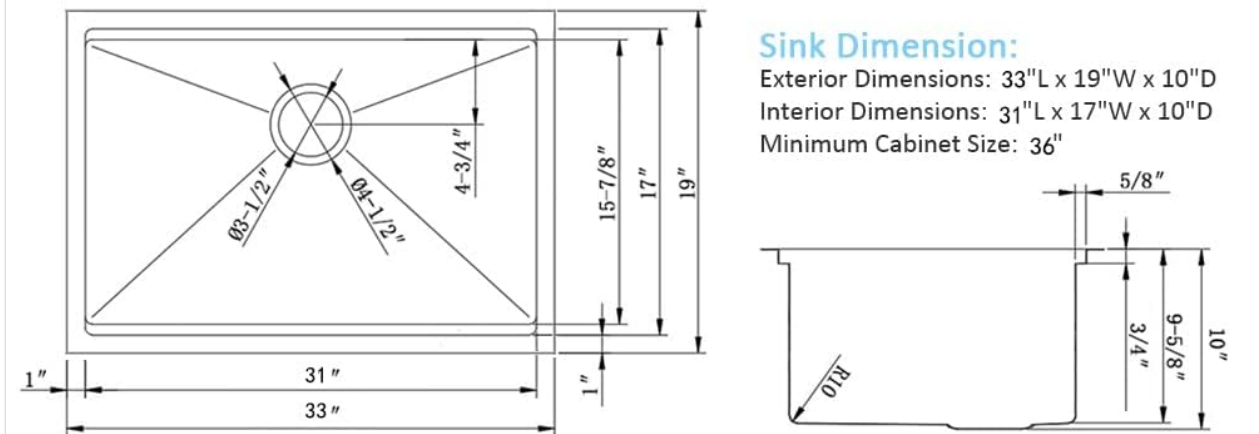

An underside view of the Bokaiya sink, highlighting the sound-proof bottom rubber pads that reduce noise from daily use and the anti-condensation undercoating that protects cabinets from moisture damage.

X Shape Water Guide

Sloped Bottom with Engineered Drain Grooves direct water toward drain to prevent water retention.



A close-up view of the Bokaiya sink's interior, illustrating the X-shape sloped bottom and engineered drain grooves designed to direct water efficiently towards the drain, preventing water retention.

7. TROUBLESHOOTING

If you encounter any issues with your sink, refer to the following common troubleshooting tips:

- **Slow Drainage:** Check the basket strainer for food debris or other obstructions. Ensure the plumbing connections are clear and not clogged.
- **Water Spots/Stains:** These are often caused by mineral deposits from hard water. Use a soft cloth with a 50/50 solution of water and white vinegar, then rinse and dry thoroughly.
- **Minor Scratches:** Stainless steel can develop minor scratches over time. These are often superficial and can be minimized with stainless steel polish, applied in the direction of the grain.
- **Leaking:** If you notice any leaks, immediately turn off the water supply. Check all plumbing connections and ensure they are tightened properly. If the issue persists, contact a professional plumber.

8. WARRANTY AND SUPPORT

Bokaiya products are manufactured to high-quality standards and are backed by a manufacturer's warranty. For specific warranty details, claims, or technical support, please refer to the warranty card included with your purchase or visit the official Bokaiya website.

Always retain your proof of purchase for warranty purposes.