

Manuals+

[Q & A](#) | [Deep Search](#) | [Upload](#)

Manuals.plus /

› [Quadratec](#) /

› Quadratec QR3 Dual Tube Rear Bumper Instruction Manual

Quadratec 120630212

Quadratec QR3 Dual Tube Rear Bumper Instruction Manual

Brand: Quadratec

Model: 120630212

1. INTRODUCTION

The Quadratec QR3 Dual Tube Rear Bumper is engineered to provide robust protection and enhanced utility for your Jeep Wrangler YJ, TJ, or Unlimited LJ. Constructed from durable steel with a textured black powder-coated finish, this bumper is designed for direct bolt-on installation, requiring no modifications to your vehicle. It features a unique dual-tube design and a cutout to accommodate oversized spare tires up to 33 inches in diameter, making it an ideal upgrade for both on-road and off-road adventures.

Quadratec®

**QR3 DUAL-TUBE REAR
BUMPER FOR WRANGLER
YJ, TJ, & UNLIMITED**



Image: Quadratec QR3 Dual Tube Rear Bumper for Jeep Wrangler YJ, TJ, & Unlimited.

2. PRODUCT FEATURES

- **Fully Welded Steel Construction:** The QR3 bumper features a fully welded steel construction with end caps that are ground and polished smooth before final finishing. This design ensures durability and seals out moisture, unlike plastic end caps.

- **Tubular Build:** Our 3-inch tubular bumpers feature mandrel bends, miter joint cuts, gusseting, and 360° welds that are ground and polished, creating a superior look and structural integrity.
- **Powder Coated Finish:** The durable textured black powder coat finish includes e-coatings for enhanced resistance against salt and water damage, ensuring long-lasting performance in various conditions.
- **Spare Tire Cutout:** Designed with a specific cutout to accommodate oversized spare tires and wheels up to 33 inches in diameter.
- **Bolt-On Installation:** Easy to install with no modifications required, thanks to integrated mounting tabs that bolt directly onto the existing mounting points on your Wrangler. Required hardware is included.



Heavy Duty Fully Welded Metal Construction.



CORROSION RESISTANCE

Sealed End Caps To Avoid
Internal Rusting

Corrosion Resistance with Sealed End Caps.

Quadratec



SPARE TIRE CUT OUT

Accommodates Tires Up To 33"

Spare Tire Cut Out accommodates tires up to 33 inches.

Quadratec®

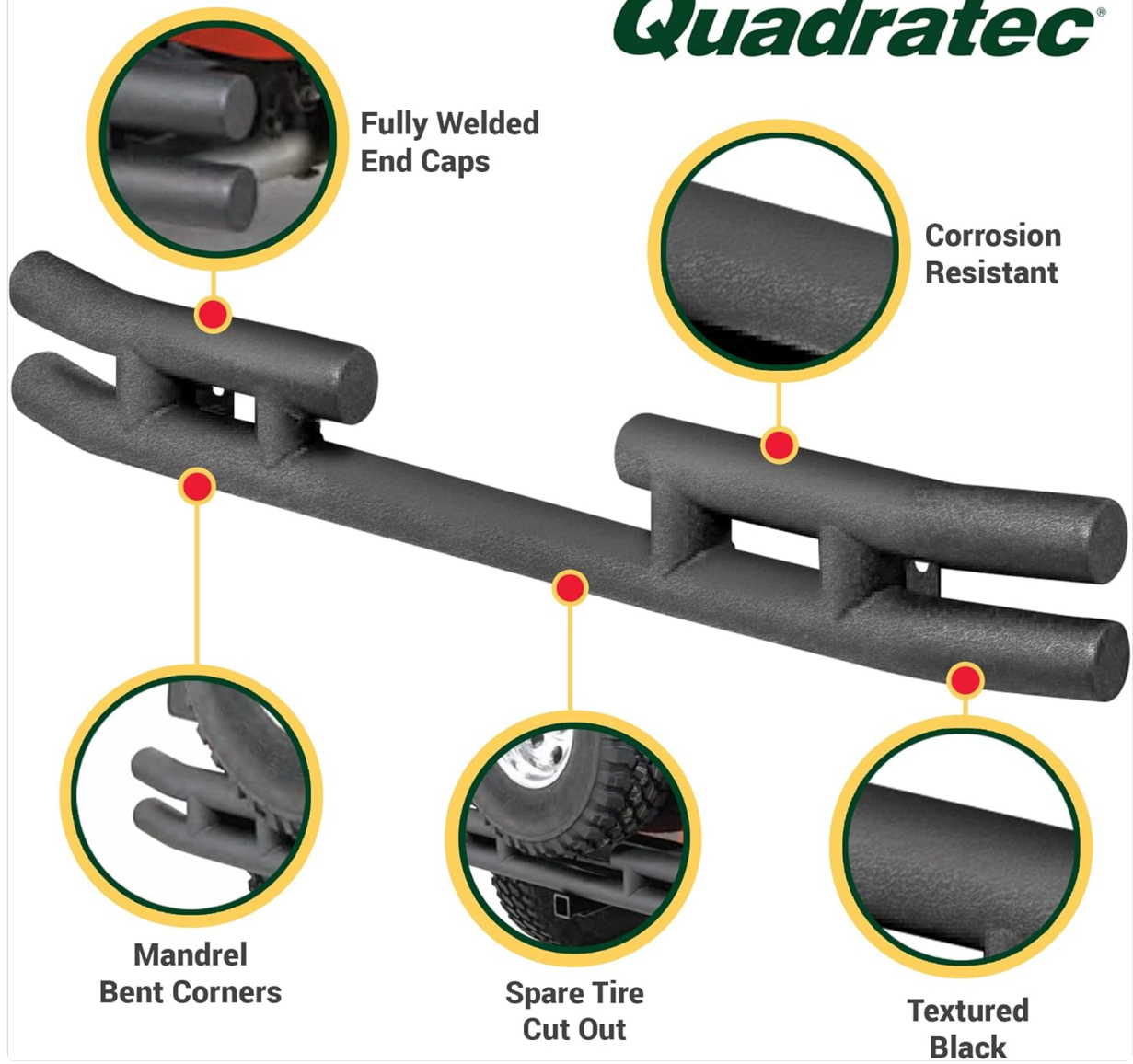

Key features: Fully Welded End Caps, Mandrel Bent Corners, Spare Tire Cut Out, Textured Black, Corrosion Resistant.

Quadratec®

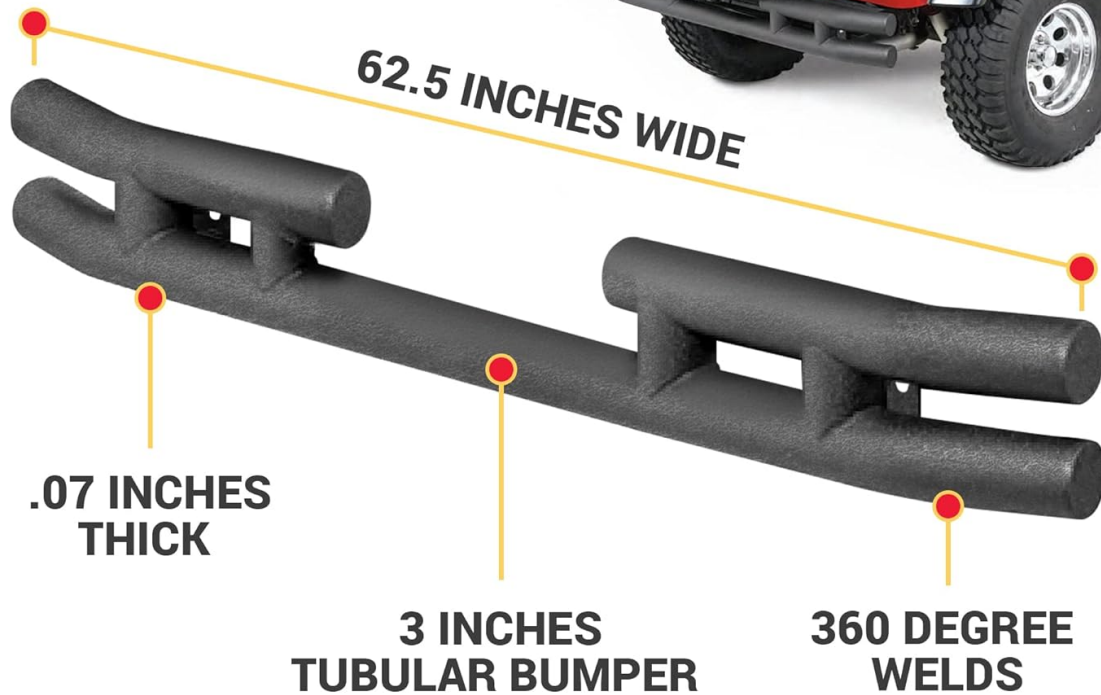

DIMENSION

Dimensions: 62.5 inches wide, .07 inches thick, 3 inches tubular bumper, 360 degree welds.

3. COMPONENTS LIST

The Quadratec QR3 Dual Tube Rear Bumper package includes the following:

- Quadratec QR3 Dual Tube Rear Bumper (Textured Black)
- All necessary mounting hardware for installation

Please inspect all components upon receipt to ensure nothing is missing or damaged. Contact Quadratec customer support immediately if any issues are found.

4. INSTALLATION GUIDE

The Quadratec QR3 Dual Tube Rear Bumper is designed for a straightforward bolt-on installation, requiring no drilling or modifications to your Jeep Wrangler's frame. For detailed, step-by-step instructions, please refer to the included installation guide provided with your bumper kit. A general overview of the installation process is as follows:

1. **Preparation:** Park your vehicle on a level surface and engage the parking brake. Gather all necessary

tools (typically basic hand tools like wrenches and sockets).

2. **Remove Existing Bumper (if applicable):** Carefully unbolt and remove your vehicle's factory rear bumper. Store any factory hardware you wish to retain.
3. **Position the New Bumper:** Align the Quadratec QR3 bumper with the existing mounting points on your Jeep's frame. It may be helpful to have an assistant for this step due to the bumper's weight.
4. **Secure the Bumper:** Using the provided hardware, loosely attach the bumper to the frame mounting points.
5. **Final Tightening:** Once the bumper is properly aligned and all bolts are in place, progressively tighten all hardware to the manufacturer's recommended torque specifications.
6. **Final Inspection:** Double-check all connections to ensure the bumper is securely mounted and stable.



Image: Quadratec QR3 Dual Tube Rear Bumper installed on a Jeep Wrangler.

5. OPERATION

The Quadratec QR3 Dual Tube Rear Bumper serves primarily as a protective component for the rear of your Jeep Wrangler. Its robust steel construction and dual-tube design offer enhanced impact resistance, safeguarding your vehicle's frame and body during off-road excursions or minor impacts. The integrated spare

tire cutout allows for the mounting of an oversized spare tire, improving clearance and aesthetics for lifted vehicles or those running larger tires.

6. MAINTENANCE

To ensure the longevity and appearance of your Quadratec QR3 Dual Tube Rear Bumper, follow these simple maintenance guidelines:

- **Regular Cleaning:** Wash the bumper regularly with mild soap and water to remove dirt, mud, salt, and other debris. Rinse thoroughly.
- **Inspect Finish:** Periodically inspect the textured black powder coat finish for any chips, scratches, or signs of wear. Minor damage can be touched up with appropriate automotive paint to prevent rust.
- **Check Hardware:** Annually, or after significant off-road use, check all mounting hardware to ensure it remains tight. Re-tighten any loose bolts to prevent rattling or movement.
- **Avoid Harsh Chemicals:** Do not use abrasive cleaners, solvents, or harsh chemicals on the bumper, as these can damage the powder coat finish.

7. TROUBLESHOOTING

While the Quadratec QR3 Dual Tube Rear Bumper is designed for optimal fitment, some users have reported specific considerations:

- **Issue:** Spare tire (33-inch diameter) appears to contact the bumper, particularly at the passenger-side edge of the upper tube cutout.
- **Possible Cause:** Variations in tire tread patterns, wheel backspacing, or specific spare tire carrier designs may cause slight interference.
- **Solution:** If interference occurs, it may be necessary to relocate the tire studs on your spare tire carrier slightly to adjust the tire's position. This typically involves minor modifications to the carrier itself, not the bumper. Consult a professional if you are unsure about performing such adjustments.

For any other installation or performance issues not covered here, please refer to the detailed installation instructions or contact Quadratec customer support.

8. SPECIFICATIONS

Specification	Detail
Brand	Quadratec
Model Number	120630212
ASIN	B09V2DRNBZ
Auto Part Position	Rear
Material	Alloy Steel

Color	Textured Black
Exterior Finish	Powder Coat
Vehicle Service Type	Jeep (Wrangler YJ, TJ, Unlimited LJ)
Special Features	Hardware Included, Direct Bolt-On Installation, Powder Coated Finish, Steel, Step-by-Step Instructions, Accommodates Spare Tires up to 33"
Dimensions (Approx.)	62.5 inches wide, 3 inches tubular design

9. WARRANTY AND SUPPORT

For information regarding product warranty, returns, or technical support, please contact Quadratec directly. Quadratec has over 30 years of experience serving the Jeep community with expert advice and a wide range of accessories. Their dedicated team is available to assist with any questions regarding installation, compatibility, or product performance.

Quadratec Contact Information: Please refer to the official Quadratec website or your purchase documentation for the most current contact details (phone, email, or online support portal).



Image: Quadratec - Three Decades of Expert Jeep Parts and Accessories.

