

OONO D-1437

OONO D-1437 2-Channel Rocker Switch Thermal Circuit Breaker User Manual

Model: D-1437

1. PRODUCT OVERVIEW

The OONO D-1437 is a 2-channel power distribution module featuring rocker switch thermal circuit breaker overload protectors. Designed for DIN rail mounting, this module provides protection against overcurrent conditions for electrical circuits. Each channel includes a 10A thermal circuit breaker, allowing manual control of the output state (RESET or OFF) and indicating normal operation with a built-in red light.

2. KEY FEATURES

- **Input Voltage:** AC 125V to 250V, 50-60Hz.
- **Maximum Total Input Current:** 20A (per position terminal block).
- **Maximum Output Current:** 10A per channel.
- **Maximum Total Output Current:** 20A.
- **Circuit Breakers:** Two 10A rocker switch thermal circuit breaker overload protectors.
- **Switch Functionality:** Manual RESET or OFF states with integrated red indicator light for normal output.
- **Terminal Blocks:** Pitch 7.62mm (0.3 inch), suitable for 26AWG to 10AWG (4.0mm square) wires.
- **DIN Rail Mount:** High-quality fireproof nylon material carrier, compatible with 35mm, 32mm, and 15mm DIN rails.
- **Construction:** FR-4 fiberglass dual copper layers PCB.

3. TECHNICAL SPECIFICATIONS

Specification	Value
Brand	OONO

Specification	Value
Model	D-1437
Input Voltage	AC 125-250V, 50/60Hz
Max Total Input Current	20A
Max Output Current (per channel)	10A
Max Total Output Current	20A
Circuit Breaker Type	Thermal, Rocker Switch
Number of Poles	2
Mounting Type	DIN Rail Mount
Terminal Block Pitch	7.62mm (0.3 inch)
Wire Range	26AWG to 10AWG (4.0mm ²)
Strip Length	8mm
Screw Material	M3, Steel, Cr3+ Zn plated
Pin Header and Cage Material	Brass
PCB Material	FR-4 fiberglass dual copper layers

4. SAFETY INFORMATION

WARNING: Electrical shock hazard. Installation and servicing should only be performed by qualified personnel. Always disconnect power at the main circuit breaker or fuse box before installing or servicing this device.

- Ensure all wiring complies with local and national electrical codes.
- Do not exceed the specified voltage and current ratings of the device.
- Verify proper wire gauge for the current load to prevent overheating.
- Ensure secure connections at all terminal blocks to prevent loose contacts and potential hazards.
- This device is designed for indoor use in dry environments. Avoid exposure to moisture or extreme temperatures.

5. SETUP AND INSTALLATION

5.1 DIN Rail Mounting

The OONO D-1437 module is designed for easy installation on standard DIN rails (35mm, 32mm, or 15mm width). To mount, align the module's clips with the DIN rail and press firmly until it snaps into place. To remove, gently pull the release mechanism (if present) or pry the module off the rail.

Typical Connection Use Method



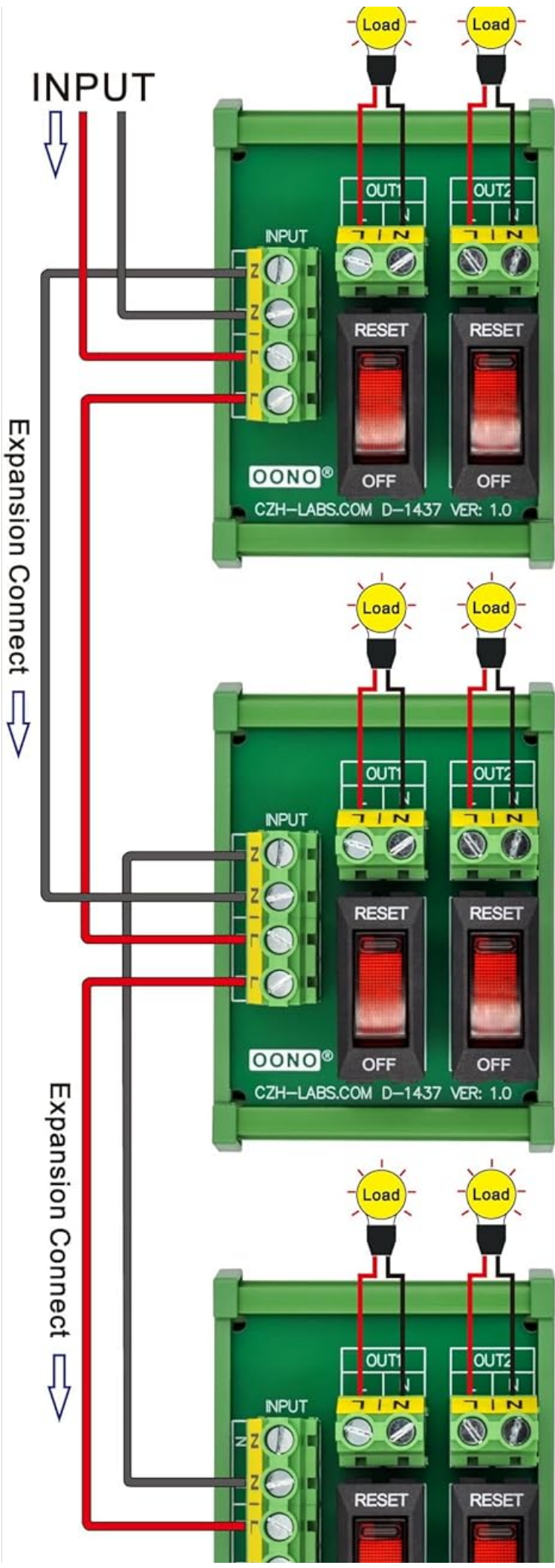



Figure 5.1: The OONO D-1437 module securely mounted on a DIN rail, demonstrating its compatibility with standard rail systems.

5.2 Wiring Connections

Refer to the schematic and connection diagrams for proper wiring. Ensure power is disconnected before making any connections.

- **Input Terminals:** Connect the AC 125-250V power supply to the input terminals labeled 'N' (Neutral) and 'L' (Line). The module supports a maximum total input current of 20A.
- **Output Terminals:** Each channel has 'L' and 'N' output terminals. Connect your load to the corresponding output channel. Each channel supports a maximum output current of 10A. The maximum total output current for the module is 20A.
- **Wire Specifications:** Use wires within the range of 26AWG to 10AWG (4.0mm²). Strip wire insulation approximately 8mm before inserting into the terminal blocks. Tighten M3 screws securely.



Figure 5.2: Front view of the OONO D-1437 module, highlighting the input and output terminal blocks and the two rocker switches for circuit protection.



Figure 5.3: Rear view of the OONO D-1437 module, illustrating the clear labeling for input and output connections (N/L for Neutral/Line).

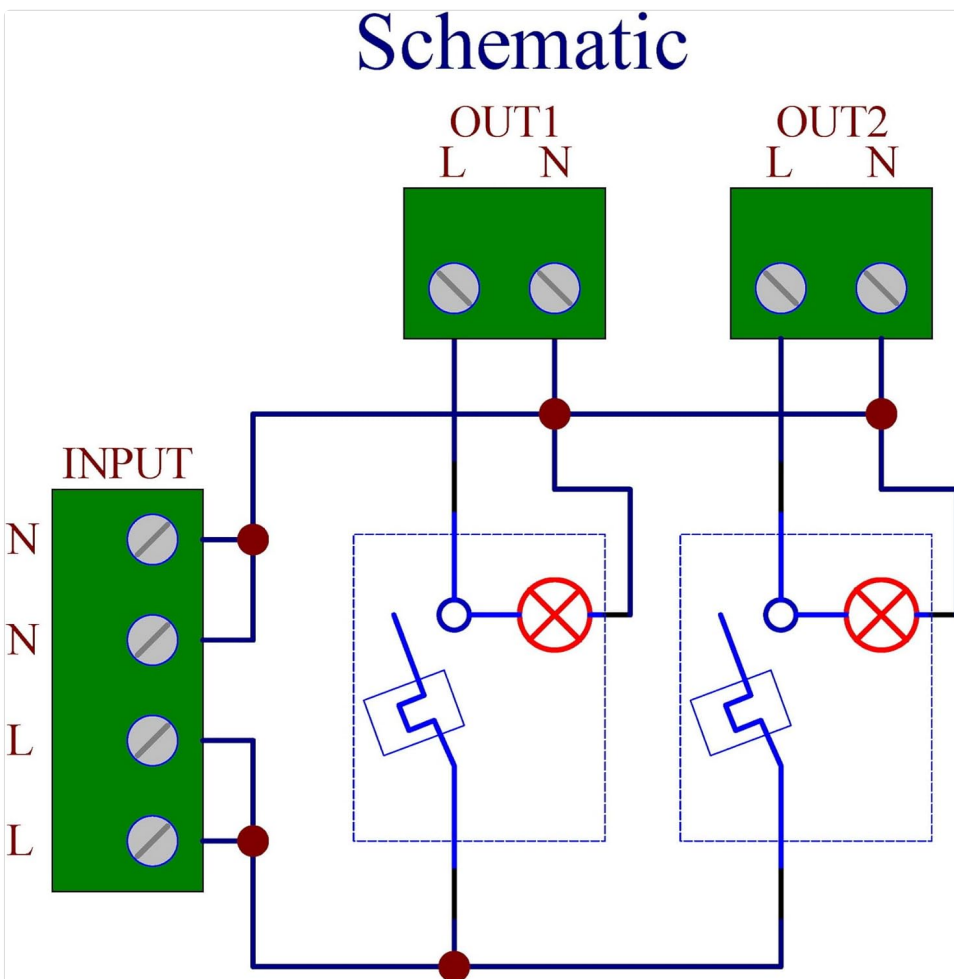

Figure 5.4: Electrical schematic diagram for the OONO D-1437, showing the internal wiring of the input, output, and circuit breaker components.

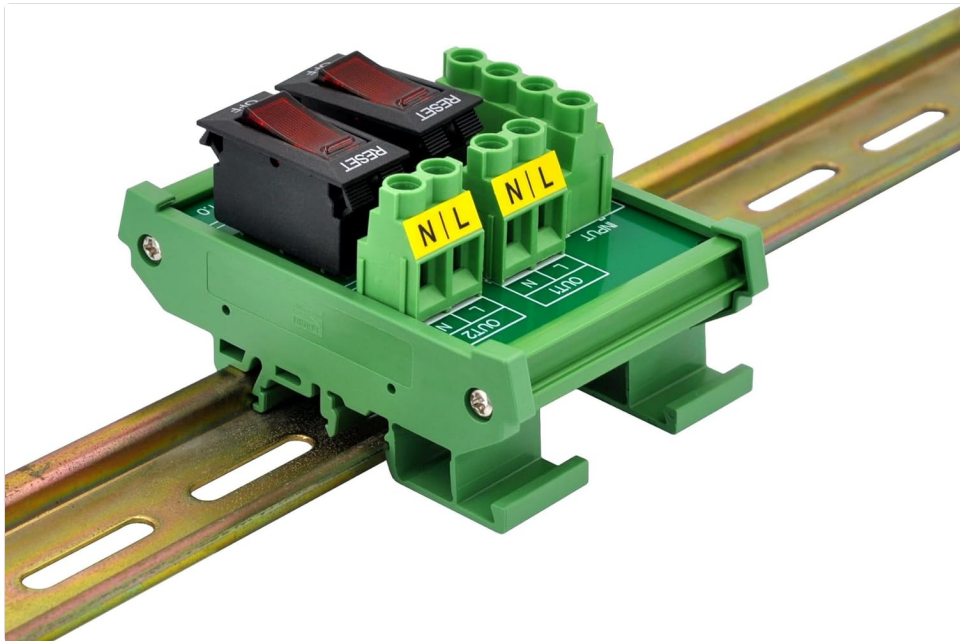

Figure 5.5: A typical connection method demonstrating how multiple OONO D-1437 modules can be wired for expanded power distribution, including input and load connections.

5.3 Dimensions

For precise integration into your electrical panel, refer to the detailed dimensional drawing below.

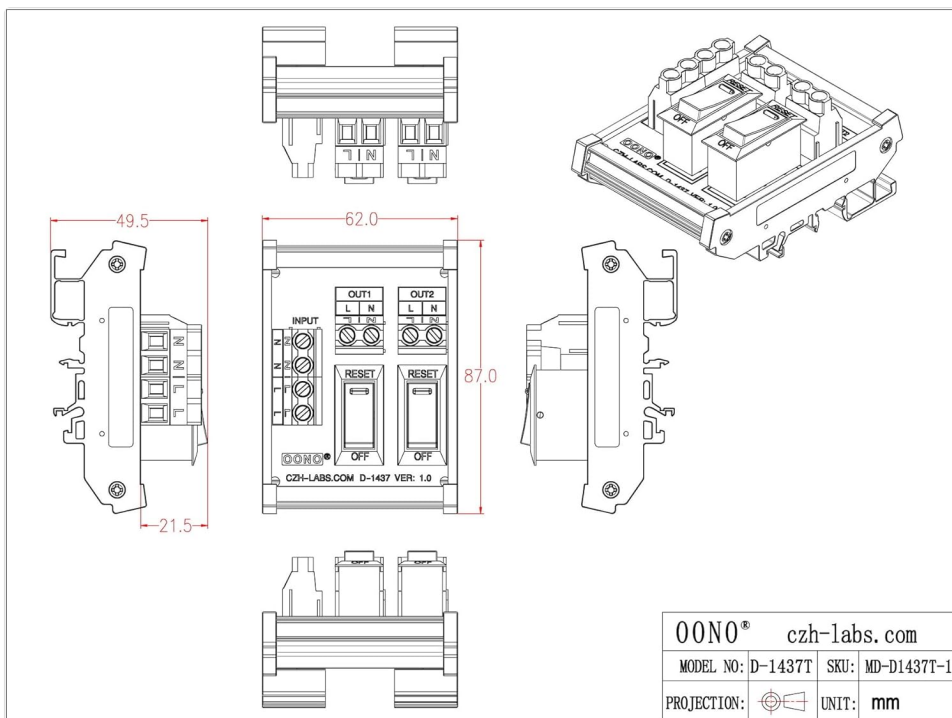

Figure 5.6: Dimensional drawing of the OONO D-1437 module, providing precise measurements in millimeters for installation planning.

5.4 Installation Overview Video

Watch this video for a visual guide on the product's features and installation process.

Your browser does not support the video tag.

Video 5.7: An overview of the OONO D-1437 Rocker Switch Thermal Circuit Breaker, demonstrating its various configurations and DIN rail mounting.

6. OPERATING INSTRUCTIONS

The OONO D-1437 features two independent rocker switches, each controlling one output channel.

- **ON/RESET Position:** When the rocker switch is pressed to the 'RESET' side, the circuit breaker is closed, allowing power to flow to the connected load. A built-in red indicator light will illuminate when the output is normal.
- **OFF Position:** When the rocker switch is pressed to the 'OFF' side, the circuit breaker is open, disconnecting power to the connected load. The red indicator light will be off.
- **Overload Protection:** In the event of an overcurrent, the thermal circuit breaker will automatically trip, moving the rocker switch to the 'OFF' position and disconnecting the load to prevent damage. To reset after an overload, allow a brief cooling period, then manually press the switch to the 'RESET' position. If the breaker trips repeatedly, investigate the cause of the overload.

7. MAINTENANCE

The OONO D-1437 is designed for minimal maintenance. However, periodic inspection is recommended to ensure optimal performance and safety.

- **Cleaning:** Ensure the module is free from dust and debris. Use a dry, soft cloth for cleaning. Do not use liquid cleaners or solvents.
- **Connection Check:** Periodically inspect all wire connections to ensure they remain tight and secure. Loose connections can lead to overheating or intermittent operation.
- **Visual Inspection:** Check for any signs of physical damage, discoloration, or burning on the module or wiring. Replace the unit immediately if any damage is observed.

8. TROUBLESHOOTING

- **No Power to Load:**
 - Check if the rocker switch is in the 'RESET' position.
 - Verify that the input power supply is active.
 - Inspect all wiring connections for looseness or damage.
- **Circuit Breaker Trips Repeatedly:**
 - This indicates an overcurrent condition. Disconnect the load and check for short circuits or excessive current draw.
 - Ensure the connected load does not exceed the 10A rating of the individual channel or the 20A total rating of the module.
 - Allow the breaker to cool down before attempting to reset.
- **Indicator Light Not On:**
 - The indicator light illuminates when the output is normal and the switch is in the 'RESET' position. If it's off, check the switch position, input power, and load connection.
 - If the breaker has tripped, the light will be off.

9. WARRANTY AND SUPPORT

For warranty information and technical support, please refer to the documentation provided at the time of purchase or contact the manufacturer directly. Keep your purchase receipt as proof of purchase.

