



Manuals.plus /

› **Lionelo /**

› Thermup Double Bottle Warmer, 2 Bottles Simultaneously, Heat Milk in 3-5 Minutes, 6 Working Modes, Steriliser and Defrost Function, Quiet Work, Safe to Use

Lionelo C-THERMUP DOUBLE WHITE

Lionelo Thermup Double Bottle Warmer User Manual

Model: C-THERMUP DOUBLE WHITE

INTRODUCTION

The Lionelo Thermup Double Bottle Warmer is a versatile device designed to simplify the feeding process for infants. It offers multiple functions including warming milk and food, fast heating, defrosting, and sterilization, all while maintaining a quiet operation. This manual provides detailed instructions for safe and effective use of your bottle warmer.



Image: The Lionelo Thermup Double Bottle Warmer shown with its product packaging, highlighting its compact design and dual bottle capacity.

SAFETY INFORMATION

Please read all safety instructions carefully before using the device to prevent injury or damage.

- **BPA-Free Materials:** The container and all parts that come into contact with food are made from BPA-free materials, ensuring safety for your child.
- **Overheating Protection:** The device is equipped with an automatic shut-off feature that activates if the temperature becomes too high, preventing damage and ensuring safety.
- **Thermostat and Fuse:** An integrated thermostat and fuse maintain a consistent water temperature and provide additional safety.
- Always ensure the device is placed on a stable, flat surface away from children's reach during operation.
- Do not immerse the main unit in water or other liquids.

- Unplug the device from the power outlet when not in use and before cleaning.



Image: Close-up of the Lionelo Thermup Double Bottle Warmer, showing the "BPA free" symbol, indicating the use of safe materials.

PRODUCT OVERVIEW

Familiarize yourself with the components of your Thermup Double Bottle Warmer.

- **Main Unit:** Houses the heating element and control panel.
- **Control Panel:** Features an LED touch screen with intuitive buttons for mode selection and temperature adjustment.
- **Bottle Compartments:** Two dedicated slots for warming bottles or food jars simultaneously.
- **Lid:** Covers the bottle compartments to retain heat and steam during operation.

Thermup Double



- **LED TOUCH SCREEN**
- **BRIGHT SCREEN - NIGHT-TIME OPERATION**

Image: The Lionelo Thermup Double Bottle Warmer displaying its LED touch screen, which is bright and designed for easy operation, even at night.

SETUP

Before first use, follow these steps:

1. Unpack all components and remove any packaging materials.
2. Wipe the exterior of the main unit with a damp cloth.
3. Clean the bottle compartments and lid with warm soapy water, then rinse thoroughly and dry.
4. Place the warmer on a stable, heat-resistant surface.
5. Ensure the power cord is securely plugged into a grounded electrical outlet.

OPERATING INSTRUCTIONS

The Thermup Double Bottle Warmer features 6 distinct operating modes to cater to various needs.

General Operation:

1. Place the bottle(s) or food jar(s) into the warming compartments.
2. Add the appropriate amount of water to the water reservoir (refer to specific mode instructions for water levels).
3. Place the lid securely on top.
4. Press the power button to turn on the device.
5. Select the desired operating mode using the touch screen controls.
6. The device will indicate when the process is complete. Carefully remove the warmed item.

Working Modes:

- **1. Milk Warming:** Heats milk or water to a selected temperature. Ideal for preparing bottles.



Thermup Double

lionelo
care

60-120ml
120-180ml
180ml ↗

+

−

⏻

Milk Warming Constant Warming Food Heating Fast & Sterilize

- **WARMING 2 BOTTLE AT THE SAME TIME**
- **KEEPS FOOD WARM FOR UP TO 24 HOURS**

Image: The bottle warmer shown warming two bottles simultaneously, demonstrating its dual capacity and efficiency for parents of twins or for warming multiple items.

- **2. Constant Temperature:** Maintains the set temperature of milk or water for up to 24 hours. Baby food can be kept warm for up to 6 hours. This ensures food is ready whenever needed.

- **3. Food Heating:** Allows you to warm baby food in jars or containers.
- **4. Fast Heating:** Rapidly heats milk or water. For example, 30 ml of milk can be heated in approximately 3 minutes.



Image: The bottle warmer highlighting its quick warming capability, stating it can warm in just 3 minutes, which is beneficial for urgent feeding needs.

- **5. Defrost:** Quickly defrosts frozen breast milk or baby food.
- **6. Sterilization:** Effectively sterilizes bottles, pacifiers, and other accessories by reaching temperatures up to 100°C, eliminating 99.9% of bacteria.

Thermup Double



- **TEMPERATURE RANGE UP TO 100° C**
- **KILLS 99,9% OF GERMS AND BACTERIA**

Image: The bottle warmer illustrating its sterilization function, capable of reaching temperatures up to 100°C to kill germs and bacteria.

Thermup Double



6W1

- **PERMANENT DEFROST**
- **STANDARD MILK/WATER WARMING**
- **FOOD WARMING**
- **QUICK WARMING**
- **STERILISATION**
- **QUICK DEFROSTING**

Image: A visual summary of the Lionelo Thermup Double Bottle Warmer's six operating modes: Permanent Defrost, Standard Milk/Water Warming, Food Warming, Quick Warming, Sterilization, and Quick Defrosting.

MAINTENANCE

Regular cleaning ensures optimal performance and hygiene.

- **Daily Cleaning:** After each use, unplug the device and allow it to cool. Empty any remaining water. Wipe the interior and exterior with a soft, damp cloth.
- **Descaling:** Mineral deposits can build up over time. Descale the warmer every 2-4 weeks, or more frequently if you have hard water.
 - a. Mix 50ml of white vinegar with 100ml of cold water.
 - b. Pour the solution into the water reservoir.
 - c. Allow it to soak for 30 minutes to an hour (do not turn on the device).
 - d. Pour out the solution and rinse the reservoir thoroughly with clean water several times.
 - e. Wipe dry with a clean cloth.

- Do not use abrasive cleaning agents, scourers, or solvents.
- Store the device in a dry place when not in use.

TROUBLESHOOTING

If you encounter issues, refer to the following common problems and solutions:

Problem	Possible Cause	Solution
Device does not turn on.	Not plugged in; power outage; faulty outlet.	Check power connection; test outlet with another device.
Warming takes too long.	Insufficient water; excessive mineral buildup; incorrect mode selected.	Ensure adequate water level; descale the device; select appropriate mode (e.g., Fast Heating).
Food/milk is too hot/cold.	Incorrect temperature setting; not enough water for steam.	Adjust temperature setting; ensure proper water level.
Sterilization not effective.	Insufficient water; lid not properly closed.	Ensure water reaches the heating element; close lid tightly to trap steam.

If the problem persists after attempting these solutions, please contact customer support.

SPECIFICATIONS

Feature	Detail
Product Dimensions	5.31 x 8.07 x 8.86 inches (approx. 13.5 x 20.5 x 22.5 cm)
Item Model Number	C-THERMUP DOUBLE WHITE
Material Composition	PP + ABS (BPA-free)
Working Modes	6 (Heating, Warming Meals, Fast Heating, Defrost, Sterilization, Constant Temperature)
Heating Time	3-5 minutes (e.g., 30ml milk in 3 minutes)
Sterilization Temperature	Up to 100°C (eliminates 99.9% of bacteria)
Constant Temperature Duration	Up to 24 hours (milk/water), 6 hours (baby food)
Item Weight	1.65 pounds (approx. 0.75 kg)
Batteries Required	No

Thermup Double

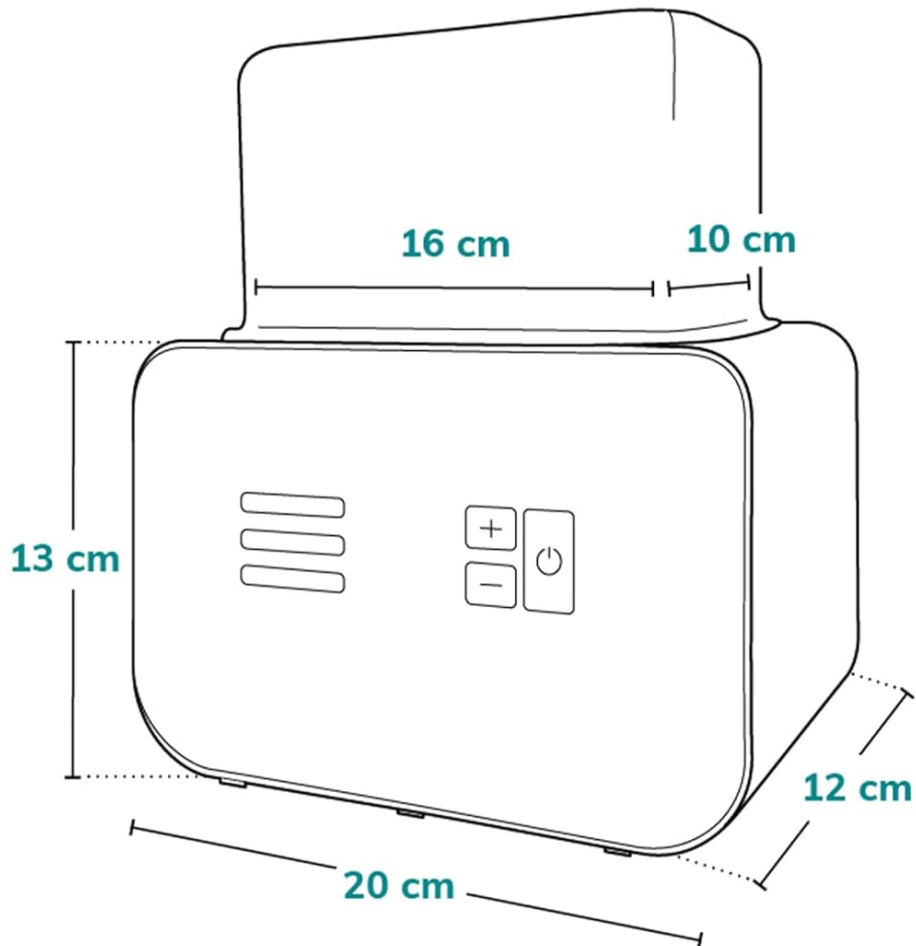

Image: A technical diagram illustrating the dimensions of the Lionelo Thermup Double Bottle Warmer, showing its height, width, and depth in centimeters.

WARRANTY AND SUPPORT

Lionelo products are designed for durability and reliability. For information regarding warranty coverage, please refer to the warranty card included with your product or visit the official Lionelo website.

For technical support, troubleshooting assistance beyond this manual, or spare parts, please contact Lionelo customer service. Contact details can typically be found on the product packaging or the official brand website.

Note: Protection plans may be available for extended coverage. Please check with your retailer for details.