

Manuals+

[Q & A](#) | [Deep Search](#) | [Upload](#)

manuals.plus /

› [Ebm Papst](#) /

› [Ebm Papst R2E190-AO26-30 Centrifugal Fan User Manual](#)

Ebm Papst R2E190-AO26-30

Ebm Papst R2E190-AO26-30 Centrifugal Fan User Manual

Model: R2E190-AO26-30

1. INTRODUCTION

This manual provides essential information for the safe and efficient installation, operation, and maintenance of the Ebm Papst R2E190-AO26-30 Centrifugal Fan. Please read this manual thoroughly before using the product to ensure proper function and longevity. This fan is designed for various industrial and commercial applications requiring efficient air movement.

2. SAFETY INFORMATION

Observe the following safety precautions to prevent injury and damage to the product:

- **Electrical Safety:** Ensure the power supply matches the fan's voltage (230V AC). All electrical connections must be performed by a qualified electrician in accordance with local and national electrical codes. Disconnect power before installation, maintenance, or troubleshooting.
- **Proper Handling:** Handle the fan with care to avoid damage to the blades or housing. Do not drop the unit.
- **Installation Environment:** Install the fan in a stable, secure location. Ensure adequate clearance for airflow and prevent obstruction of the inlet and outlet. The operating temperature range is -25°C to +55°C.
- **Protection:** The fan has an IP44 protection rating, indicating protection against solid objects larger than 1mm and splashing water. It is not suitable for submersion or direct water jets.
- **Moving Parts:** Keep hands, tools, and loose clothing away from moving parts during operation.

3. PRODUCT OVERVIEW

The Ebm Papst R2E190-AO26-30 is an AC centrifugal fan featuring a backward-curved, single-inlet design. It is constructed from durable plastic and utilizes ball bearings for reliable operation. This fan is engineered for efficient

cooling and ventilation in various systems, including those with inverters.



Figure 3.1: Top-down view of the EBM Papst R2E190-AO26-30 centrifugal fan, showing the central motor and backward-curved blades within the housing.

Model:R2E190-AO26-30

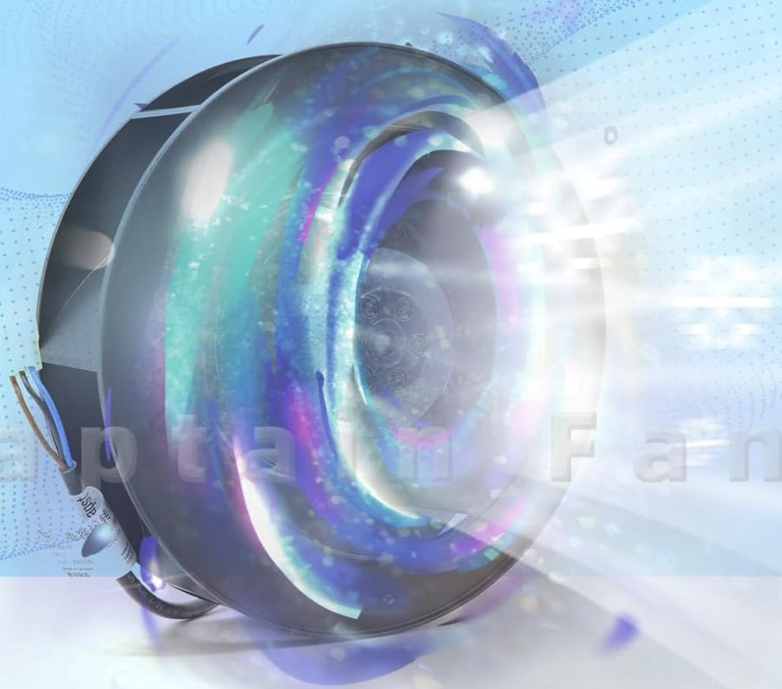

Current
0.26A

Voltage
230V

Power
58W

Speed
2500min⁻¹

Figure 3.2: The R2E190-AO26-30 fan highlighting key electrical parameters: Current 0.26A, Voltage 230V, Power 58W, and Speed 2500 RPM.

Size: ϕ 190mm



Figure 3.3: Dimensions of the R2E190-AO26-30 centrifugal fan, showing a diameter of 190mm and a depth of 68.5mm.

R2E190-AO26-30

AC centrifugal fan

backward-curved, single-intake

Product drawing

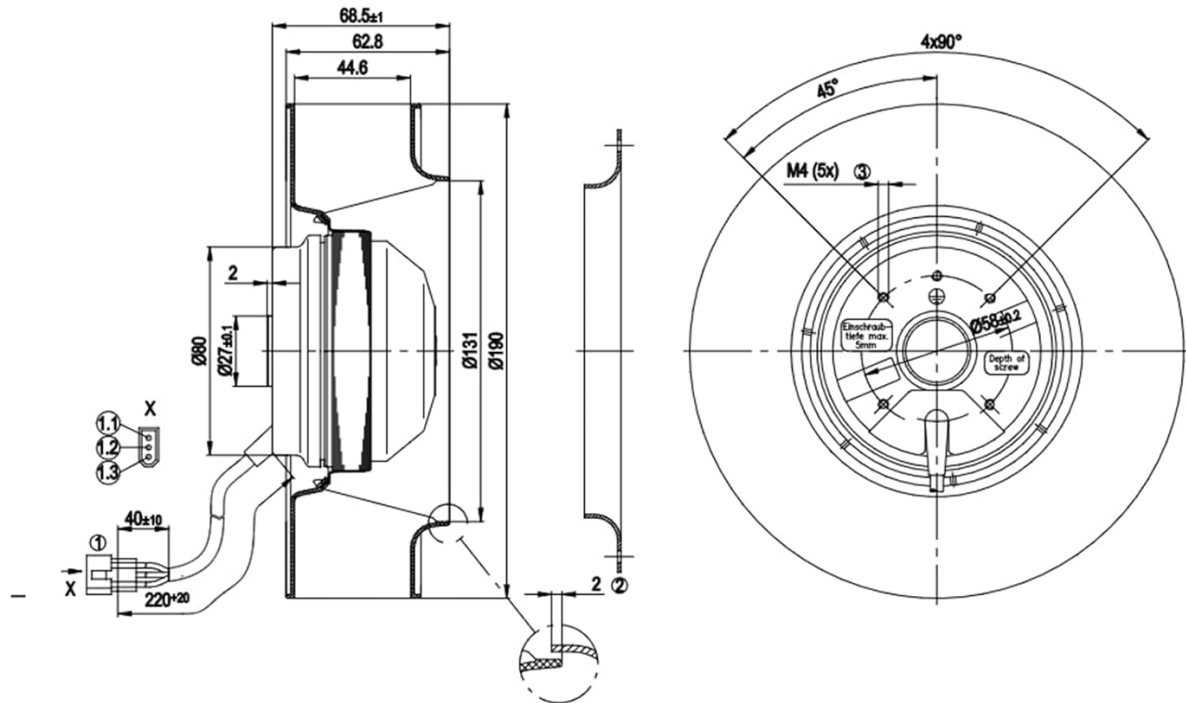

Figure 3.4: Detailed product drawing of the R2E190-AO26-30 AC centrifugal fan, including precise measurements and mounting points.

4. SPECIFICATIONS

Parameter	Value
Model	R2E190-AO26-30
Brand	Ebm Papst
Bearing Type	Ball
Fan Diameter	190 mm
Material	Plastic
Type	Centrifugal cooling fan, backward curved, single-inlet
Number of Blades	7
Maximum Fan Speed	2700 RPM
Operating Temperature	-25°C to +55°C

Parameter	Value
Frequency	50/60 Hz
Current Type	AC
Type of Protection	IP 44
Phase	1~
Current	0.26~0.34 A
Voltage	230 V
Wattage	80 W
Maximum Airflow Volume	365 CFM
Power Connector Type	3-Pin
Cooling Method	Air
Compatible Devices	Inverter
UPC	768681195834

5. SETUP AND INSTALLATION

Proper installation is crucial for the fan's performance and safety. It is recommended that installation be performed by a qualified professional.

- Mounting:** Securely mount the fan using appropriate fasteners. Refer to the product drawing (Figure 3.4) for mounting hole dimensions and patterns. Ensure the fan is mounted on a stable surface that can support its weight and absorb any vibrations.
- Airflow Direction:** Position the fan to ensure the intended airflow direction. The fan is a single-inlet centrifugal type, designed to draw air from one side and expel it radially.
- Electrical Connection:** Connect the fan to a 230V AC power supply using its 3-pin power connector. Ensure all wiring is correctly insulated and secured. Verify that the power circuit is protected by an appropriate circuit breaker or fuse.
- Inverter Compatibility:** This fan is compatible with inverters. When connecting to an inverter, follow the inverter manufacturer's instructions for wiring and parameter settings to ensure optimal performance and prevent damage.
- Clearance:** Maintain adequate clearance around the fan's inlet and outlet to prevent airflow restriction, which can lead to reduced performance and overheating.

6. OPERATION

Once properly installed and connected to the power supply, the Ebm Papst R2E190-AO26-30 fan operates continuously when power is applied. No specific user controls are typically present on the fan unit itself, as its operation is usually managed by the system it is integrated into (e.g., an inverter or control panel).

- **Initial Start-up:** After installation, apply power and observe the fan for smooth operation, unusual noises, or vibrations.
- **Continuous Operation:** The fan is designed for continuous duty within its specified operating temperature range.
- **Monitoring:** Periodically monitor the fan's performance and the temperature of the equipment it is cooling to ensure effective operation.

7. MAINTENANCE

Regular maintenance helps ensure the fan's longevity and optimal performance.

- **Power Disconnection:** Always disconnect power to the fan before performing any maintenance.
- **Cleaning:** Periodically inspect the fan blades and housing for dust, dirt, or debris accumulation. Clean with a soft brush or compressed air. Avoid using harsh chemicals or abrasive materials that could damage the plastic components.
- **Inspection:** Check for any signs of physical damage, loose connections, or unusual wear. Ensure mounting screws remain tight.
- **Bearings:** This fan uses ball bearings, which are typically sealed and require no lubrication. If unusual noise from the bearings is detected, the fan may require replacement.

8. TROUBLESHOOTING

If the fan is not operating as expected, consult the following troubleshooting guide:

Problem	Possible Cause	Solution
Fan does not start	No power supply Incorrect wiring Damaged motor	Check power connection and circuit breaker Verify wiring against diagram Contact support for replacement
Reduced airflow	Blocked inlet/outlet Dirty blades Motor speed issue	Clear obstructions Clean fan blades Check power supply stability or inverter settings
Unusual noise or vibration	Loose mounting Damaged blades/bearings Debris in fan	Tighten mounting screws Inspect blades for damage, contact support if bearings are faulty Clean fan thoroughly

Problem	Possible Cause	Solution
Overheating	Insufficient airflow Operating outside temperature range	Ensure proper clearance and clean fan Verify ambient temperature is within -25°C to +55°C

If problems persist after attempting these solutions, contact customer support.

9. APPLICATIONS

The Ebm Papst R2E190-AO26-30 centrifugal fan is versatile and suitable for a wide range of applications requiring efficient air movement and cooling. Its robust design and compatibility with inverters make it ideal for demanding industrial environments.

- Ventilation systems
- Air conditioning units
- Refrigeration equipment
- Heating systems
- Electrical automation cabinets
- Frequency variators (inverters)
- Rail transit systems
- Air purification systems
- New energy applications



Figure 9.1: The R2E190-AO26-30 fan integrated with Siemens frequency converters, demonstrating its use in inverter-driven systems.

10. WARRANTY AND SUPPORT

For warranty information, please refer to the terms and conditions provided at the time of purchase or contact your vendor. For technical support, troubleshooting assistance beyond this manual, or inquiries regarding spare parts, please contact the seller or manufacturer directly.

Note: No official product videos were provided in the available data for embedding in this manual.