



Manuals.plus /

› Surpass Hobby USA /

› SURPASS HOBBY Rocket Mini 1410 7500KV Brushless Motor and 18A ESC Combo User Manual

**Surpass Hobby USA SP-014102-04**

# **SURPASS HOBBY Rocket Mini 1410 7500KV Brushless Motor and 18A ESC Combo User Manual**

Model: SP-014102-04

---

## **1. INTRODUCTION**

---

This manual provides comprehensive instructions for the SURPASS HOBBY Rocket Mini 1410 7500KV Brushless Motor and Mini 18A Brushless Electronic Speed Controller (ESC) Combo. This high-performance power system is designed for 1/24 and 1/28 scale RC mini cars, offering efficient power conversion and reliable operation. Please read this manual thoroughly before installation and operation to ensure proper use and longevity of your product.



Image 1: The SURPASS HOBBY Rocket Mini 1410 7500KV Brushless Motor and Mini 18A Brushless ESC Combo.

# BRUSHLESS POWER SYSTEM

MINI 1410 brushless motor with MINI 18A brushless ESC combo set

SUITABLE MINI CAR



Image 2: Overview of the brushless power system, highlighting its suitability for mini RC cars.

## 2. SETUP AND INSTALLATION

Proper installation is crucial for optimal performance and safety. Follow these steps carefully:

- 1. Motor Mounting:** Secure the Mini 1410 motor to your RC car's chassis using appropriate M2.0 or M1.6 screws. Ensure the motor is firmly attached to prevent movement during operation.
- 2. Motor to ESC Connection:** Connect the three motor wires to the corresponding output wires on the 18A ESC. While brushless motors can typically be connected in any order, reversing two wires will reverse motor rotation if needed.
- 3. ESC to Receiver Connection:** Plug the ESC's signal cable into the throttle channel (usually Channel 2) of your RC receiver.
- 4. Battery Connection:** Connect your LiPo (1-2 cells) or NiMH (3-4 cells) battery to the ESC's power input connector. Ensure correct polarity.
- 5. ESC Calibration:** Refer to your RC transmitter and receiver manual for throttle range calibration. This typically involves powering on the transmitter, then the ESC while holding the throttle at full, then neutral, then off positions to set the endpoints.



Image 3: Close-up view of the motor's internal windings and external connection points.

### 3. OPERATING INSTRUCTIONS

---

Once installed and calibrated, your brushless power system is ready for operation:

1. Ensure all connections are secure and the battery is fully charged.
2. Turn on your RC transmitter first, then connect the battery to the ESC.
3. The ESC will typically emit a series of beeps indicating successful initialization and battery cell count.
4. Operate your RC car using the transmitter. The brushless motor provides smooth and powerful acceleration.
5. After use, disconnect the battery from the ESC first, then turn off your transmitter.

### 4. MAINTENANCE

---

Regular maintenance helps prolong the life and performance of your motor and ESC:

- **Cleaning:** Periodically clean the motor and ESC to remove dirt, dust, and debris. Use a soft brush or compressed air. Avoid using liquids directly on electronic components.

- **Motor Bearings:** Inspect motor bearings for smooth operation. If they feel rough or noisy, they may need lubrication or replacement.
- **Wiring and Connectors:** Check all wires and connectors for signs of wear, fraying, or corrosion. Replace damaged components immediately.
- **Heat Management:** Ensure adequate airflow around the motor and ESC during operation. Excessive heat can damage components. Monitor temperatures, especially during extended use.

## 5. TROUBLESHOOTING

---

If you encounter issues, refer to the following common troubleshooting steps:

- **No Power:** Check battery charge, all connections (battery to ESC, ESC to receiver), and ensure the ESC is properly armed.
- **Motor Not Spinning:** Verify motor wire connections, ESC calibration, and ensure the motor is not obstructed. Check for any damage to the motor or ESC.
- **Erratic Behavior:** Re-calibrate the ESC throttle range. Check for radio interference or loose connections. Ensure the battery is providing sufficient power.
- **Overheating:** Reduce load on the motor, check for proper gearing, ensure adequate cooling, and verify that the motor and ESC are suitable for the application.

## 6. SPECIFICATIONS

---

Detailed specifications for the SURPASS HOBBY Rocket Mini 1410 Brushless Motor and Mini 18A Brushless ESC:

### Motor Specifications (Mini 1410)

- **KV (RPM/Volt):** 7500KV
- **Watts:** 80
- **Max Voltage:** 8.0V
- **Max Amps:** 11A
- **IO:** 0.6A
- **Resistance:** 0.14Ω
- **Rotor Poles:** 2
- **Max RPM:** 60000
- **Length:** 25mm (0.98in)
- **Diameter:** 15mm (0.59in)
- **Shaft Diameter:** 2mm
- **Length of Extend Shaft:** 10mm (0.39in)
- **Design:** 2 Pole 3 Slot Hi-torque Motor Design
- **Can Material:** CNC Machined 6061 T6 Billet Aluminum Heatsink Can
- **Windings:** High Purity Copper Windings
- **Bearings:** High RPM ABEC5 Oversized Bearings
- **Stator:** Super Thin (0.2mm) Laminations

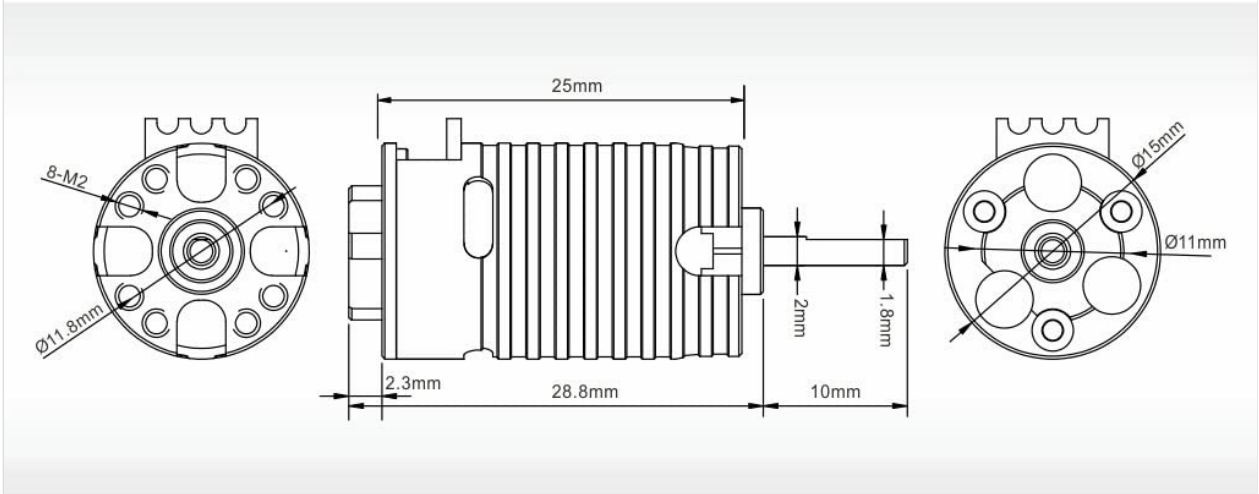

Image 4: Dimensional diagram of the Mini 1410 Brushless Motor, showing key measurements.

- CNC Machined 6061 T6 Billet Aluminum Heatsink Can
- 2 Pole 3 Slot Hi-torque Motor Design
- Stator - Super Thin (0.2mm) Laminations



Product	Item Number	KV (RPM/Volt)	Watts	Max voltage	Max Amps	Rotor Poles	IO	Resistance	Max RPM	Motor size (mm)	Weight (g)	Shaft (mm)	Length of extend shaft
MINI1410	SP-014100-10	2500	80	<8.4V	8A	2	0.1A	1.25	60000	Ø15x25	12.5	Ø2	10mm
MINI1410	SP-014100-11	3500	80	<8.4V	9A	2	0.25A	1.0	60000	Ø15x25	12.5	Ø2	10mm
MINI1410	SP-014100-12	5500	80	<8.4V	10A	2	0.5A	0.28	60000	Ø15x25	12.5	Ø2	10mm
MINI1410	SP-014100-13	7500	80	<8.0V	11A	2	0.6A	0.14	60000	Ø15x25	12.5	Ø2	10mm
MINI1410	SP-014100-14	9500	80	<6.0V	12A	2	0.8A	0.1	60000	Ø15x25	12.5	Ø2	10mm

Image 5: Table detailing specifications for various Mini 1410 motor variants, including KV, Watts, Max Amps, and dimensions.

### ESC Specifications (Mini 18A)

- **Continuous Current / Burst Current:** 12A / 36A
- **Battery Compatibility:** 1-2 cells LiPo; 3-4 cells NiMH
- **Motor Type:** Used for sensorless brushless motor
- **BEC Output:** 5V / 300mA (analog mode)
- **Suitable Car:** Mini car (1/24, 1/28 scale)
- **Dimensions:** 15mm x 26mm x 11.5mm

# MINI 18A Brushless ESC

SUITABLE MINI CAR



<b>Cont. Current/ Burst Current:</b> 12A/36A	<b>Battery:</b> 1~2 cells Lipo , 3~4 cells NiMH
<b>Motor Type:</b> Sensorless Brushless Motor	<b>BEC Output:</b> 5V/300mA (analog mode)
<b>Suitable Car:</b> mini car	<b>Dimension:</b> 15x26x11.5mm

Image 6: The Mini 18A Brushless ESC with its dimensions and key specifications listed.

## 7. WARRANTY AND SUPPORT

SURPASS HOBBY products are manufactured to high standards. This product is covered by a manufacturer's warranty against defects in materials and workmanship. Please retain your proof of purchase for warranty claims. For specific warranty terms and conditions, or for technical support, please contact SURPASS HOBBY USA directly through their official channels.

For further assistance, visit the official SURPASS HOBBY website or contact their customer service department.