

## Manuals+

[Q & A](#) | [Deep Search](#) | [Upload](#)

manuals.plus /

› [ZoneFly](#) /

› [ZoneFly Thermal Fuses for Electric Pressure Cookers: Installation and Operation Manual \(Model VES385\)](#)

## ZoneFly VES385

# ZoneFly Thermal Fuses for Electric Pressure Cookers: Installation and Operation Manual

Model: VES385

## 1. INTRODUCTION

This manual provides essential information for the installation, operation, and troubleshooting of ZoneFly thermal fuses for electric pressure cookers. These thermal fuses are critical safety components designed to protect your appliance from overheating by interrupting the electrical circuit if a dangerous temperature is reached.

Please read this manual thoroughly before attempting any installation or repair to ensure safe and correct usage.

## 2. PRODUCT OVERVIEW

The ZoneFly thermal fuses are designed as replacement parts for various electric pressure cooker models. They act as a safety mechanism, preventing potential damage to the appliance and ensuring user safety by cutting off power when internal temperatures exceed a safe limit.

### 2.1 Key Features

- Rated Operating Temperature: 185 °C
- Rated Current: 10A
- Rated Voltage: 250V / AC (Compatible with 100V to 240V electricity, including 110V in the USA)
- Durable construction for reliable performance.

### 2.2 Compatibility

These thermal fuses are compatible with a wide range of electric pressure cookers, including:

- **Instant Pot Models:** DUO, ULTRA, LUX (3, 6, 8, and 10 Quart sizes)
- **PowerXL/Quick Pot Multi Cooker Models:** Y4D-36, Y6D-36, Y8D-36, Y10D-36



**Fits Many  
Pressure Cooker**

**Image Description:** An image displaying several models of electric pressure cookers, including Instant Pot and PowerXL/Quick Pot, indicating their compatibility with the thermal fuses. The text 'Fits Many Pressure Cooker' is visible at the bottom right.

### 3. SPECIFICATIONS

Parameter	Value
Brand	ZoneFly
Model Number	VES385
Rated Operating Temperature	185 °C
Rated Current	10A
Rated Voltage	250V / AC
Material	Stainless steel (implied for fuse body/leads)
Product Dimensions	1.99"D x 0.98"W x 0.91"H (Overall package dimensions, individual fuse dimensions vary)

Parameter	Value
Item Weight	0.176 ounces (for the 3-pack)

## RY 130°C 250V 10A

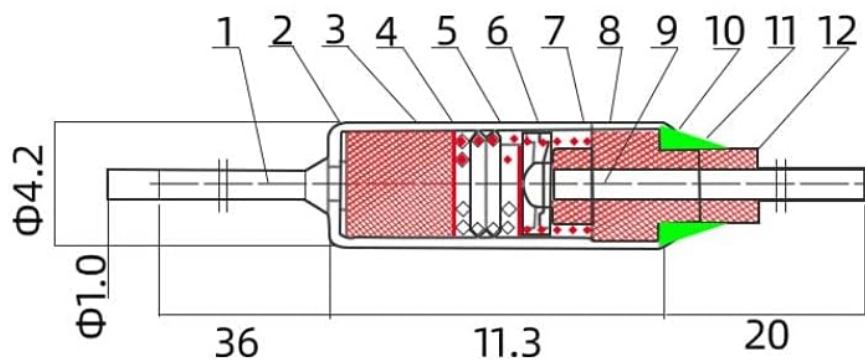
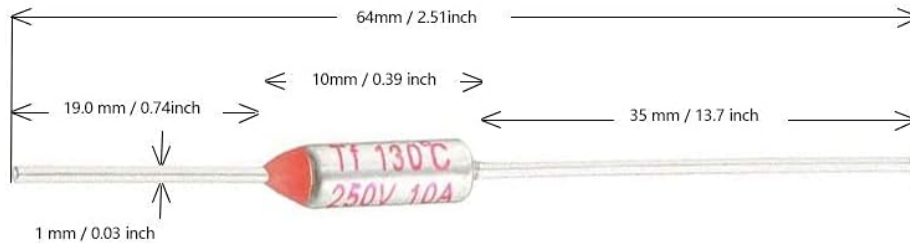

1 : Outgoing line	7 : Spring
2 : Temperature sensitive body	8 : Metal shell
3 : Shim	9 : Electric shock wire
4 : Spring	10 : Magnetic beads
5 : Shim	11 : Sealing glue
6 : Moving contact	12 : Contact wire sleeve (porcelain tube)

**Image Description:** A technical diagram illustrating the internal structure and dimensions of a thermal fuse. Key components like the outgoing line, temperature sensitive body, spring, moving contact, metal shell, electric shock wire, magnetic beads, sealing glue, and contact wire sleeve are numbered and labeled.

## 4. OPERATING PRINCIPLES

A thermal fuse operates as a one-time, non-resettable safety device. Its primary function is to protect electrical appliances from damage caused by overheating. It contains a temperature-sensitive element that melts and breaks the circuit when a specific temperature is reached.

### 4.1 Before Activation

Under normal operating conditions, the current flows continuously through the fuse's lead wires and internal metallic components. The circuit remains closed, allowing the appliance to function.

### 4.2 After Activation

If the appliance's internal temperature rises to the fuse's rated operating temperature (185 °C), the temperature-sensitive body inside the fuse melts. This action causes a drum spring to relax, moving a contact pad away from the contact wire, thereby breaking the electrical circuit and cutting off power to the appliance.

## Working principle

### Before action

At this operating temperature, the current flows from one end of the lead wire through the metal, and from the contact piece to the other end of the lead wire (contact wire), making the circuit smooth (and vice versa)

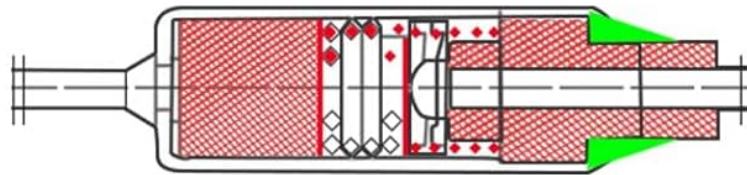

### After action

When the equipment is in the normal working state, due to the temperature rise, when it reaches the set temperature of the thermal fuse, the sensing body temperature melts, the drum spring automatically relaxes, and the contact pad moves under the action of the straight spring, which causes the contact pad and contact wire to break, and the circuit to be cut off

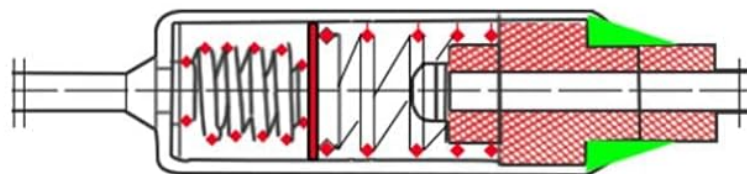

**Image Description:** A two-part diagram showing the internal state of a thermal fuse. The 'Before action' section depicts the fuse in a closed circuit state, with current flowing. The 'After action' section shows the fuse in an open circuit state, where the internal element has melted, breaking the connection due to overheating.

## 5. INSTALLATION AND REPLACEMENT

**Warning:** Working with electrical appliances carries risks. Ensure the pressure cooker is unplugged from the power outlet before beginning any inspection or replacement. If you are not comfortable performing electrical repairs, seek assistance from a qualified technician.

### 5.1 Identifying a Blown Fuse

A common indicator of a blown thermal fuse is when your electric pressure cooker does not power on or its display remains dark after being plugged into a power outlet. This suggests the fuse has activated to protect the appliance.

## 5.2 Replacement Procedure (General Steps)

1. **Disconnect Power:** Unplug the pressure cooker from the wall outlet.
2. **Access Internal Components:** Carefully disassemble the pressure cooker to gain access to the internal wiring and the existing thermal fuse. This usually involves removing the bottom panel. Refer to your specific pressure cooker's service manual or online resources for detailed disassembly instructions.
3. **Locate the Fuse:** Identify the thermal fuse, which is typically a small cylindrical component connected in series with the power supply.
4. **Remove Old Fuse:** Desolder or carefully cut the wires connected to the old fuse. Note the orientation if applicable, though thermal fuses are generally non-polar.
5. **Install New Fuse:** Solder or securely connect the new ZoneFly thermal fuse into the circuit, ensuring a strong electrical connection. Use appropriate heat-shrink tubing or electrical tape for insulation if necessary.
6. **Reassemble:** Carefully reassemble the pressure cooker, ensuring all components are correctly seated and wires are not pinched.
7. **Test:** Plug the pressure cooker back into the power outlet and test its functionality.

**Note:** Replacement of the fuse can often be completed in a few minutes by individuals with basic electrical repair skills. After replacement, your cooker may resume normal operation.



**Image Description:** A product image showing three individual ZoneFly thermal fuses with their specifications (185°C, 250V, 10A) printed on them, positioned next to a modern electric pressure cooker.

## 6. TROUBLESHOOTING

### 6.1 No Power / Display Off

If your pressure cooker shows no signs of power (e.g., display is off, no response to buttons) after being plugged in, the thermal fuse is a primary suspect. This indicates the fuse has likely blown due to an internal overheating event or a fault within the appliance.

- **Solution:** Replace the thermal fuse following the installation steps in Section 5.
- **Important:** If the new fuse blows shortly after replacement, it indicates an underlying issue within the pressure cooker (e.g., faulty heating element, short circuit). In such cases, further diagnosis by a qualified technician is recommended to prevent repeated fuse failures and potential hazards.

## 7. SAFETY INFORMATION

- Always disconnect power to the appliance before performing any maintenance or repair.
- Ensure replacement fuses match the original specifications (185 °C, 10A, 250V) to maintain the

appliance's safety design.

- Do not bypass or attempt to repair a blown thermal fuse. Always replace it with a new, correctly rated fuse.
- If you are unsure about any step of the installation process, consult a professional electrician or appliance repair technician.
- Keep electrical components away from moisture.

## **8. SUPPORT INFORMATION**

---

ZoneFly is committed to providing high-quality products and customer satisfaction. If you encounter any issues or have questions regarding your ZoneFly thermal fuses, please refer to the following:

- For product-related inquiries or assistance, please contact ZoneFly customer service through the retailer where the product was purchased.
- If you received the wrong size or changed your mind, please contact the seller for return or exchange options.