

[Manuals.plus](#) /

› [CNCTOPBAOS](#) /

› CNCTOPBAOS 750W AC Servo Motor Kit with Brake (Model 80F-B0230WML-Z / SDF08NK8X1) Instruction Manual

## CNCTOPBAOS 80F-B0230WML-Z (Motor), SDF08NK8X1 (Driver)

# CNCTOPBAOS 750W AC Servo Motor Kit with Brake

Model: 80F-B0230WML-Z (Motor) / SDF08NK8X1 (Driver)

Instruction Manual

## 1. INTRODUCTION

---

This manual provides essential information for the safe and efficient installation, operation, and maintenance of your CNCTOPBAOS 750W AC Servo Motor Kit. This kit is designed for high-precision motion control applications in CNC routers, robotics, and industrial automation. Please read this manual thoroughly before using the product to ensure proper functionality and to prevent damage or injury.

## 2. SAFETY INFORMATION

---

Always observe the following safety precautions to prevent electric shock, fire, or mechanical injury:

- **Electrical Safety:** Ensure all power connections are made by qualified personnel. Disconnect power before performing any wiring or maintenance. Use appropriate grounding.
- **Mechanical Safety:** Moving parts can cause injury. Keep hands and clothing clear of the motor shaft during operation. Securely mount the motor and driver to prevent unexpected movement.
- **Environmental Conditions:** Operate the unit within specified temperature and humidity ranges. Avoid exposure to moisture, dust, corrosive gases, or excessive vibrations.
- **Proper Use:** Use the servo motor and driver only for their intended purpose. Do not modify the components.

## 3. PRODUCT OVERVIEW

---

The CNCTOPBAOS 750W AC Servo Motor Kit includes a high-performance servo motor and a matched servo driver, designed for precise control and robust operation.

### 3.1 Key Components



Figure 3.1.1: Various views of the 750W AC Servo Motor (Model 80F-B0230WML-Z).



Figure 3.1.2: Various views of the SDF08NK8X1 AC Servo Driver.

### 3.2 Motor Features

- **Model:** 80F-B0230WML-Z
- **Power:** 750W
- **Encoder:** 23-bit multi-turn absolute value optical encoder for high positioning accuracy.
- **Brake:** Integrated braking function.
- **Waterproof Grade:** IP65

### 3.3 Driver Features

- **Model:** SDF08NK8X1
- **Voltage:** AC170-253V (single-phase or three-phase 220V).
- **Control Mode:** SVPWM.

- **Display:** Six-segment seven-segment LED display with four function keys.
- **Protection:** Under-voltage, over-voltage, overload, over-current, encoder exception, position error.
- **Control Modes:** Position control, speed control, torque control, jog operation, and RS485 communication.
- **Internal PLC:** Eliminates the need for an external PLC in simple control scenarios.

## 4. SPECIFICATIONS

---

### 4.1 Motor Specifications (Model 80F-B0230WML-Z)

Parameter	Value
Power	750W
Poles	5 pairs
Voltage	220V
Rated Speed	3000 r/min
Peak Speed	6000 r/min
Rated Torque	2.39 N.m
Instantaneous Max Torque	7.17 N.m
Rated Current	3.8A
Insulation Class	F
Waterproof Grade	IP65
Net Weight	2.97 kg (6.54 lb)

### 4.2 Driver Specifications (Model SDF08NK8X1)

Parameter	Value
Max Current	10.5A
Voltage	AC170-253V
Cooling Method	Heat dissipation air cooling
Control Mode	SVPWM
Operating Temperature	0~55°C
Storage Temperature	-20~80°C
Protection Level	IP54
Display	Six of seven-segment display LED

### 4.3 Dimensions

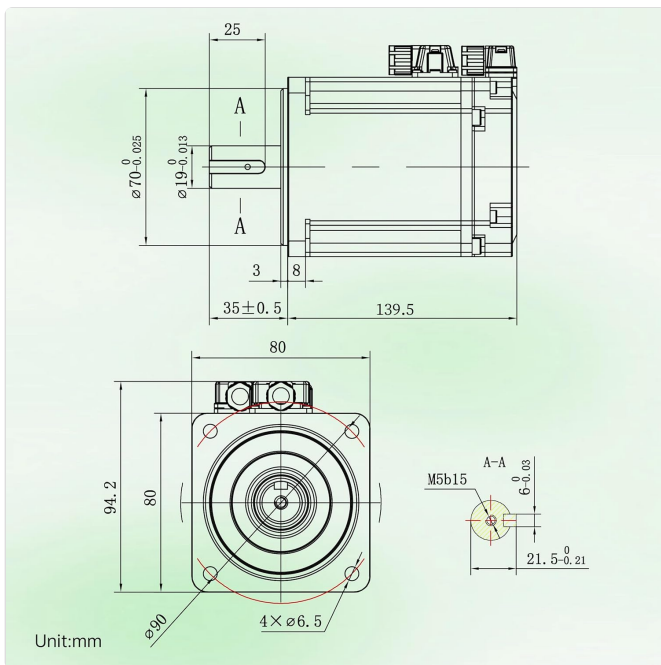

Figure 4.3.1: Motor Dimensions (Unit: mm).

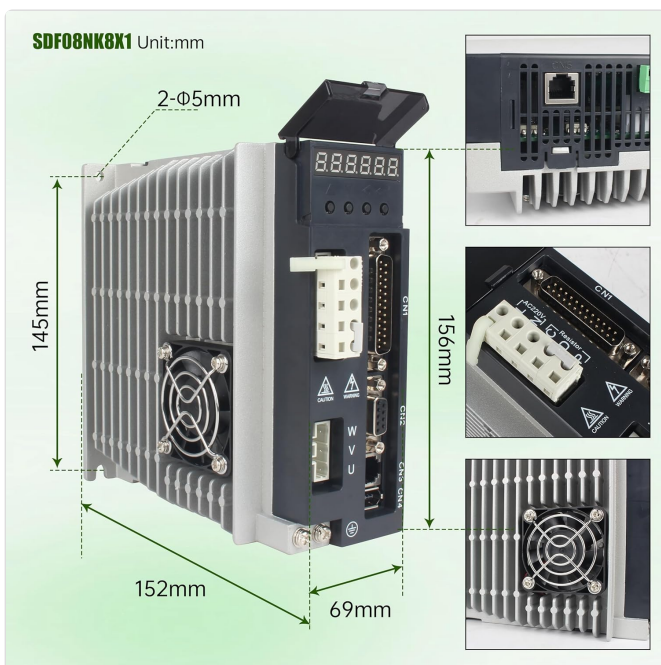

Figure 4.3.2: Driver Dimensions (Unit: mm).

## 5. SETUP

### 5.1 Wiring Connections

Careful wiring is crucial for the proper and safe operation of the servo system. Refer to the following diagrams for correct connections.

# SDF08NK8X1

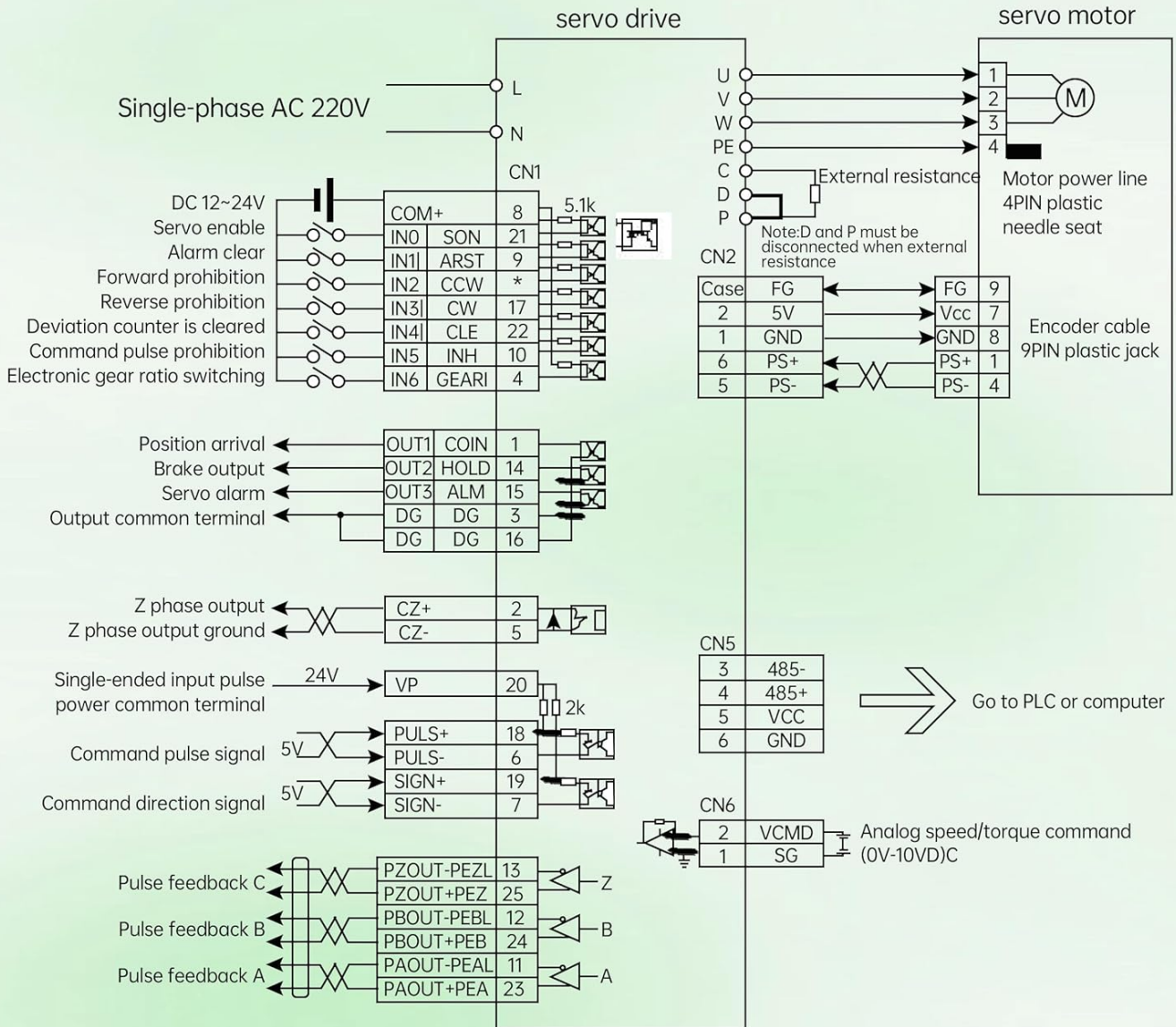

Figure 5.1.1: General Wiring Diagram for Single-phase AC 220V.



Figure 5.1.2: Control Terminal CN1 Pinout.

**Motor Winding and Encoder Connections:**



Figure 5.1.3: Motor Winding and Encoder Socket Wiring.

- The motor winding plug is designed to prevent flying and splashing water.
- The motor wire does not include an adapter plug, which reduces the chance of poor contact.

## 5.2 Initial Power-Up

After all connections are securely made, apply power to the servo driver. Observe the display for any error codes. If an error occurs, refer to the Troubleshooting section.

## 6. OPERATING INSTRUCTIONS

The SDF08NK8X1 servo driver supports multiple control modes and offers extensive parameter customization.

### 6.1 Control Modes

The driver supports the following control modes:

- **Position Control:** For precise positioning applications.

- **Speed Control:** For maintaining a constant motor speed.
- **Torque Control:** For applications requiring constant torque output.
- **Jog Operation:** For manual movement and testing.

## 6.2 Parameter Adjustment

The driver features 137 adjustable parameters covering control modes, gains, I/O definitions, and communication settings. These can be configured via the built-in display and function keys or through debugging software via RS485 communication.

## 6.3 RS485 Communication

The standard RS485 communication function allows for network control, parameter upload/download, and monitoring from a host computer or PLC.

## 6.4 Internal PLC Function

For simple control scenarios, the internal PLC function can eliminate the need for an external PLC, offering a more cost-effective solution.

## 6.5 Operation Demonstration

Your browser does not support the video tag.

Video 6.5.1: Demonstration of AC Servo Motor operation and testing (400W model shown as example).

# 7. MAINTENANCE

---

Regular maintenance ensures the longevity and optimal performance of your servo motor kit.

- **Cleaning:** Keep the motor and driver free from dust and debris. Use a soft, dry cloth for cleaning. Do not use solvents.
- **Inspection:** Periodically check all wiring connections for tightness and signs of wear or damage. Inspect the motor shaft for any obstructions or unusual play.
- **Cooling:** Ensure adequate airflow around the servo driver for proper heat dissipation. Keep cooling fins clear.

# 8. TROUBLESHOOTING

---

This section provides solutions to common issues. For problems not listed here, contact technical support.

## 8.1 Common Error Codes and Solutions

Error Code/Symptom	Possible Cause	Solution
<b>AL03 Alarm</b>	Input voltage outside specified range (e.g., too high for 220V system).	Verify input voltage is within AC170-253V. Adjust power supply if necessary.
<b>Motor not moving/responding</b>	Incorrect wiring, power supply issue, encoder connection problem, parameter misconfiguration.	Check all wiring according to diagrams. Verify power supply. Inspect encoder cable. Review driver parameters.
<b>Motor vibrates excessively</b>	Improper gain settings, mechanical load issues, motor mounting.	Adjust driver gain parameters. Check for mechanical binding or imbalance. Ensure secure motor mounting.

Error Code/Symptom	Possible Cause	Solution
<b>Overload/Over-current alarm</b>	Excessive mechanical load, short circuit, incorrect current limit setting.	Reduce mechanical load. Check for short circuits in motor wiring. Verify current limit parameters.

## 9. WARRANTY AND SUPPORT

---

For warranty information, please refer to the terms and conditions provided at the time of purchase or contact your vendor. For technical support, assistance with setup, operation, or troubleshooting, please contact CNCTOPBAOS customer service or your authorized distributor. Provide your product model and a detailed description of the issue for efficient support.