

[Manuals.plus](#) /

> [coucheta](#) /

> coucheta Full Bed Frame with Storage 14 Inch Metal Platform Bed Frame Full with Steel Slat Support No Box Spring Needed Heavy Duty Full Size Bed Frame Mattress Foundation Easy to Assemble Instruction Manual

coucheta 1

coucheta Full Bed Frame Instruction Manual

Model: 1

1. INTRODUCTION

Thank you for choosing the coucheta Full Bed Frame. This metal platform bed frame is designed for durability, stability, and convenience, offering ample under-bed storage and eliminating the need for a box spring. This manual provides comprehensive instructions for assembly, operation, maintenance, and troubleshooting to ensure a seamless experience and long-term satisfaction with your new bed frame.

2. SAFETY INFORMATION

WARNING:

- Do not exceed the weight limit of **551 lbs**. Overloading may cause structural damage and injury.
- Assemble carefully to prevent instability. Ensure all bolts and connections are securely tightened before use.
- Keep small parts away from children during assembly to prevent choking hazards.
- Periodically check all connections to ensure they remain tight.
- Exercise caution around the frame's corners to prevent injury. Consider adding corner protectors if desired.

3. PACKAGE CONTENTS

Please verify that all components are present before beginning assembly. If any parts are missing or damaged, please contact customer support.

- Headboard and Footboard sections
- Side Rails
- Center Support Bar(s)
- Steel Slats

- Support Legs
- Hardware Pack (bolts, nuts, washers, Allen wrench)
- Protective Foot Plugs
- Anti-skid Baffles for mattress retention
- Assembly Instructions

4. SETUP AND ASSEMBLY

The coucheta Full Bed Frame is designed for easy assembly, typically requiring one to two people and no additional tools beyond what is provided. Follow these general steps:

1. **Unpack and Identify Parts:** Lay out all components on a clean, soft surface to prevent scratches. Refer to the parts list in your included assembly guide.
2. **Assemble Frame Sections:** Connect the headboard and footboard sections to the side rails using the provided hardware. Ensure all connections are snug but do not fully tighten yet.
3. **Install Center Support:** Attach the center support bar(s) and any associated legs to the main frame.
4. **Place Slats:** Position the steel slats across the frame. The design ensures strong support for your mattress without the need for a box spring.
5. **Final Tightening:** Once all components are in place, systematically tighten all bolts and screws.
6. **Attach Protective Features:** Install the protective foot plugs on the bottom of the legs to prevent floor scratches. Place the anti-skid baffles on the frame to prevent mattress movement.



Figure 4.1: The assembled bed frame, showcasing its sturdy metal construction and ample under-bed clearance for storage. A plant and storage bin are visible, demonstrating potential use of the space.

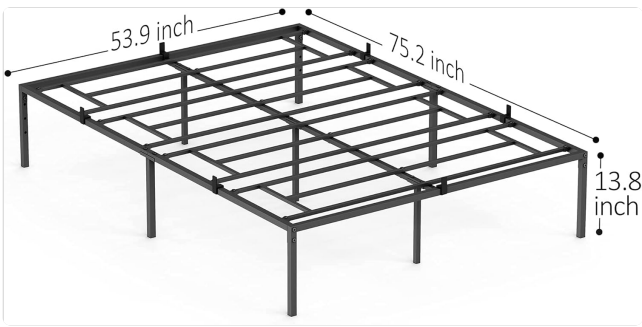

Figure 4.2: Detailed dimensions of the bed frame, showing a length of 75.2 inches, width of 53.9 inches, and height of 13.8 inches. This image helps in planning room layout and understanding the frame's size.



Figure 4.3: The bed frame with all steel slats properly installed, ready to support a mattress. This view highlights the robust slat system that eliminates the need for a box spring.



Figure 4.4: The fully assembled bed frame with a mattress and bedding, demonstrating its sleek, minimalist design that complements various bedroom decors. Two storage boxes are visible underneath.



Figure 4.5: A close-up view of the generous under-bed storage space, showing two fabric storage bins fitting comfortably. The 12.9-inch clearance provides ample room for various items.



Figure 4.6: This image illustrates the practical under-bed clearance, with a large suitcase easily fitting beneath the frame. The 12.8-inch clearance is highlighted, emphasizing the ample storage capacity.



Figure 4.7: A detailed view showcasing the 'No Slip Design' baffles that prevent the mattress from sliding and the 'Protective Foot Pads' at the base of the legs to safeguard floors.



Figure 4.8: Another close-up highlighting the protective foot pads, which prevent floor scratches, and the anti-skid design elements that secure the mattress in place.

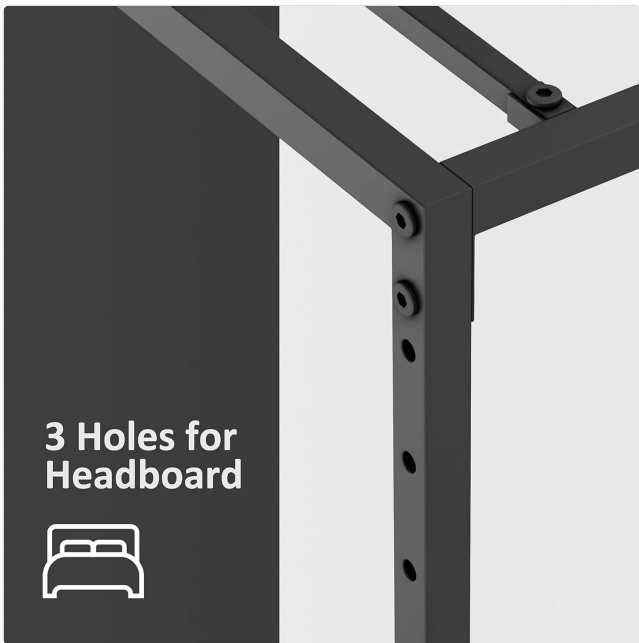

Figure 4.9: A close-up of the bed frame's leg, showing three pre-drilled holes for optional headboard attachment, offering versatility for customization.



Figure 4.10: A detailed image showing how the frame components connect, illustrating the secure and straightforward assembly mechanism.



Figure 4.11: A close-up of a bolted connection point on the bed frame, demonstrating the secure fastening method used for stability.

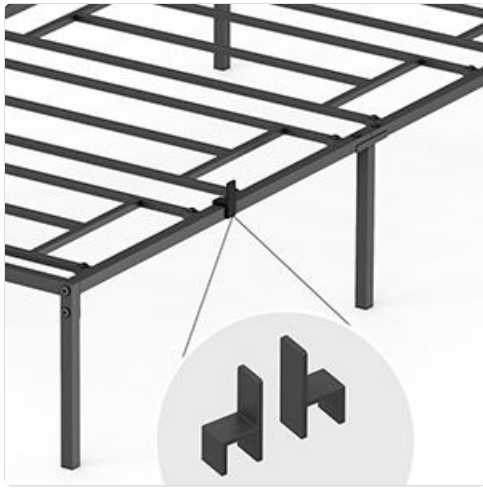

Figure 4.12: A detailed view of the anti-skid baffles, small L-shaped brackets designed to prevent the mattress from shifting on the frame.

5. OPERATING INSTRUCTIONS

Once assembled, the coucheta Full Bed Frame is ready for use. It is designed to support various mattress types, including memory foam, spring, and hybrid mattresses, without the need for a box spring.

- **Mattress Placement:** Carefully place your full-size mattress directly onto the steel slats. The anti-skid baffles will help keep the mattress in position.
- **Weight Distribution:** Ensure weight is distributed evenly across the frame. Do not concentrate heavy loads on a single point.
- **Under-Bed Storage:** Utilize the 12.9-inch clearance for storage. Storage boxes, suitcases, or other items can be neatly stored underneath, helping to keep your room organized.

6. MAINTENANCE

Regular maintenance will help prolong the life and performance of your bed frame.

- **Cleaning:** Wipe the metal frame with a soft, damp cloth. Avoid harsh chemicals or abrasive cleaners that could damage the finish.
- **Check Connections:** Periodically (e.g., every 3-6 months) inspect all bolts and connections to ensure they are still tight. Re-tighten if necessary to maintain stability and prevent squeaking.
- **Slat Inspection:** Ensure all steel slats are properly seated and not bent or damaged.

7. TROUBLESHOOTING

Here are solutions to common issues you might encounter:



Problem	Possible Cause	Solution
Bed frame squeaks	Loose connections; friction between metal parts.	Tighten all bolts. Ensure foam seal tapes are properly placed on the center bearing bar to prevent noise from friction.

Problem	Possible Cause	Solution
Mattress slides on frame	Anti-skid baffles not installed or improperly placed.	Verify that the anti-skid baffles are correctly installed on all four sides of the frame.
Frame feels unstable/wobbly	Loose connections; uneven floor.	Re-tighten all bolts. Ensure the bed frame is on a level surface. Adjust protective foot plugs if possible.
Missing parts upon delivery	Packaging error or transit damage.	Contact coucheta customer support immediately with your order details and a list of missing parts.

8. SPECIFICATIONS

Feature	Detail
Brand	coucheta
Model Number	1
Size	Full
Product Dimensions (L x W x H)	75.2" x 53.9" x 13.8"
Material	Metal & Steel
Color	Black
Weight Capacity (Static Pressure)	Up to 551 lbs
Under-Bed Clearance	12.9 inches
Box Spring Required	No
Assembly Required	Yes
Special Features	No Box Spring Needed, Squeak Resistant, Under Bed Storage, Non-slip & Noise Free Design

Product Dimension

Item	Bed Frame Size	Mattress Size
Queen	L80*W60.3*H13.8"	L80*W60"
Full	L 75.2*W53.9*H13.8"	L75*W54"

Item	Bed Frame Size	Mattress Size
Twin	L75.2*W39*H13.8"	L75*W39"

Figure 8.1: A table detailing the bed frame and compatible mattress sizes for Queen, Full, and Twin models. For the Full size, the bed frame is L75.2" x W53.9" x H13.8" and fits a L75" x W54" mattress.

9. WARRANTY AND SUPPORT

For warranty information, missing parts, or any other inquiries, please contact coucheta customer support through the retailer where you purchased the product. Please have your purchase receipt and model number ready for faster assistance.

You can typically find contact information on the retailer's website or within your order details.