

## HTU BS-G126

# HTU Car Phone Holder Model BS-G126 User Manual

Model: BS-G126 | Brand: HTU

## 1. INTRODUCTION

This manual provides detailed instructions for the installation, operation, maintenance, and troubleshooting of your HTU Car Phone Holder Model BS-G126. Please read this manual carefully before use to ensure proper functionality and safety.

## 2. WHAT'S IN THE BOX

The package includes the following components:

- 1 x Adjustable Phone Holder (fits large phones/thick cases)
- 1 x HTU Cable Manager
- 1 x Suction Cup Mount
- 1 x Air Vent Clip (fits vertical/horizontal air vents)
- 1 x User Manual
- 1 x Packaging Box



Figure 2.1: Included Components

### 3. SETUP AND INSTALLATION

The HTU Car Phone Holder offers multiple mounting options: dashboard, windshield, and air vent.

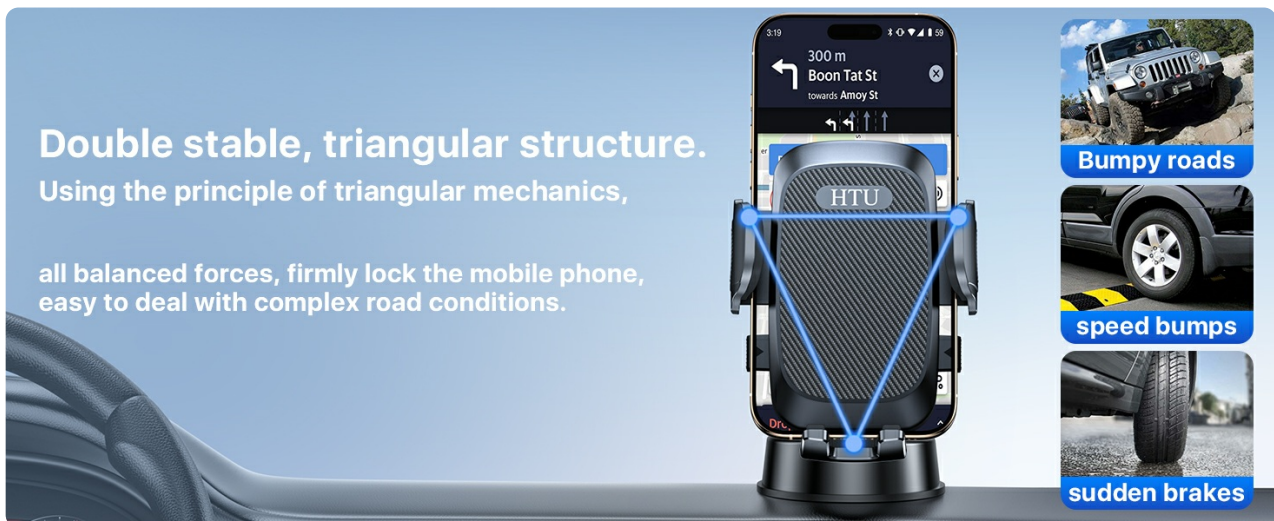

Figure 3.1: Multiple Mounting Options

#### 3.1 General Preparation

1. Ensure the mounting surface (dashboard, windshield, or air vent) is clean and dry. Use a wet cloth to wipe the dashboard if necessary.
2. For optimal adhesion, install the suction cup in a temperature range of 68°F to 77°F (10°C to 25°C) and allow 1 hour before use.

#### 3.2 Suction Cup Mount Installation (Dashboard/Windshield)

1. Unscrew the nut on the back of the phone holder.
2. Place the nut around the ball joint of the telescopic arm.
3. Insert the ball joint into the holder socket and screw the nut tightly to secure.
4. Clean the desired mounting surface thoroughly.
5. Remove the protective film from the suction cup.

6. Press the suction cup firmly onto the surface for 5 seconds.
7. Press the lock button on the suction cup base after 3 seconds to create a strong vacuum seal.
8. Adjust the two knobs on the telescopic arm to find the suitable viewing angle and distance.



Figure 3.2: Suction Cup Installation Steps

Your browser does not support the video tag.  
Video 3.1: Installation on Dashboard and Windshield

### 3.3 Air Vent Clip Installation

1. Unscrew the nut on the back of the phone holder.
2. Place the nut around the ball joint of the air vent clip.
3. Insert the ball joint into the holder socket and screw the nut tightly to secure.
4. Attach the air vent clip to a suitable air vent blade. Ensure it is securely fastened.



Figure 3.3: Air Vent Clip Installation

Your browser does not support the video tag.  
Video 3.2: Air Vent Mounting Demonstration

## 4. OPERATING INSTRUCTIONS

## 4.1 Inserting and Removing Your Phone

1. To open the holder arms, press the release buttons located on the sides of the holder.
2. Place your phone into the holder, ensuring it rests on the bottom support feet.
3. Gently push the side arms inwards until they securely grip your phone. The holder is designed to accommodate phones from 4 to 7 inches, including those with thick cases.
4. To remove your phone, press the release buttons on the sides, and the arms will open.



Figure 4.1: Phone Compatibility and Insertion

Your browser does not support the video tag.

Video 4.1: Phone Insertion and Removal

## 4.2 Adjusting Viewing Angle

The phone holder features a 360° rotatable ball joint and an adjustable telescopic arm (up to 9.84 inches / 24.9 cm) for optimal viewing angles. The installation angle can be adjusted up to 270 degrees.

- Rotate the phone holder to switch between portrait and landscape orientations.
- Adjust the telescopic arm length and angle using the knobs to position your phone for safe and relaxed driving.



Figure 4.2: Multi-Angle Flexible Adjustment

## 4.3 Cable Management

Use the included HTU Cable Manager to keep your charging cable tidy and prevent tangles. Attach it to a suitable position on your dashboard or console.



Figure 4.3: Cable Manager in Use

## 5. MAINTENANCE

### 5.1 Cleaning the Suction Cup

If the suction cup loses its stickiness, rinse it with warm water and air-dry it. This will restore its adhesive properties.



Figure 5.1: Cleaning the Suction Cup

### 5.2 General Cleaning

Wipe the phone holder with a soft, damp cloth as needed. Avoid using harsh chemicals or abrasive cleaners.

## 6. TROUBLESHOOTING

### 6.1 Suction Cup Not Sticking

- Ensure the dashboard or windshield surface is clean and dry before installation.
- Rinse the suction cup with warm water and air-dry to restore stickiness.
- Certain surfaces, such as leather (except faux leather/synthetic leather), waxed, or oiled dashboards, are not compatible with the suction cup. Use the mount on the windshield or air vent instead.
- For maximum adhesion, install the suction cup in a temperature range of 68°F to 77°F (10°C to 25°C) and

leave it for 1 hour before use.

## 6.2 Phone Holder Instability

- Ensure all knobs and the suction cup lock are securely tightened after installation.
- The holder features a triangular structure and robust clamping force to maintain stability even on bumpy roads or during sudden braking.



Figure 6.1: Stable Design for Various Road Conditions

## 6.3 Overheating in High Temperatures

- When the temperature is above 95°F (35°C) or when your car is constantly exposed to direct sunlight, it is recommended to use the air vent clip instead of the suction cup. This can also help cool your phone.

## 6.4 No Wireless Charging

- This product does not include wireless charging functionality. Please use a charging cable with the provided cable manager.

# 7. SPECIFICATIONS

Feature	Detail
Brand	HTU
Model Number	BS-G126
Color	Black
Compatible Devices	iPhone, Samsung, Google, LG, Huawei, Sony, Motorola, Nexus, Asus, Blackberry, Microsoft, ZTE, Alcatel, Amazon, Lenovo, Xiaomi

Compatible Phone Models	iPhone 17/17 Air/17 Pro/17 Pro Max, 16 Pro/16 Pro Max, 15 Pro/15 Pro Max, 14 Pro/14 Pro Max/14 Mini, 13 Pro/13 Pro Max/13/13 Mini, 12 Mini/12 Pro Max/12 Pro/12, SE, 11/Xs Max/XR/X/8/8 Plus/6/6S/7/7 Plus; Samsung Galaxy S25/S25+/S25 Ultra, S24/S24+/S24 Ultra, S23 Ultra/S23+/S23, S22 Ultra/S22+/S22, S21 Ultra/S21+/S21, S20 Ultra/S20+/S20, S23 FE; A71 5G UW/A71 5G/A71/A70, A56 5G/A55 5G/A54 5G/A53 5G/A52 5G/A51 5G UW/A51 5G/A51/A50, A42 5G/A36 5G/A35 5G/A32 5G/A32; Google Pixel 10/10 Pro/10 Pro XL, 9/9 Pro/9 Pro XL/9a, 8/8 Pro/8a, 7/7 Pro/7a, 6/6 Pro/6a, 5/5a 5G, 4/4 XL/4a/4a 5G
Mounting Type	Dashboard, Windshield, Air Vent
Weight Capacity (Maximum)	80 Pounds
Water Resistance Level	Moisture Resistant
Compatible Vehicle Type	Automobile
Item Dimensions	3.95 x 1.15 x 1.18 inches
Item Weight	10.93 ounces
Arm Length	7.2 Inches
Material	PTTE, Shockproof Silicone, Carbon Fiber

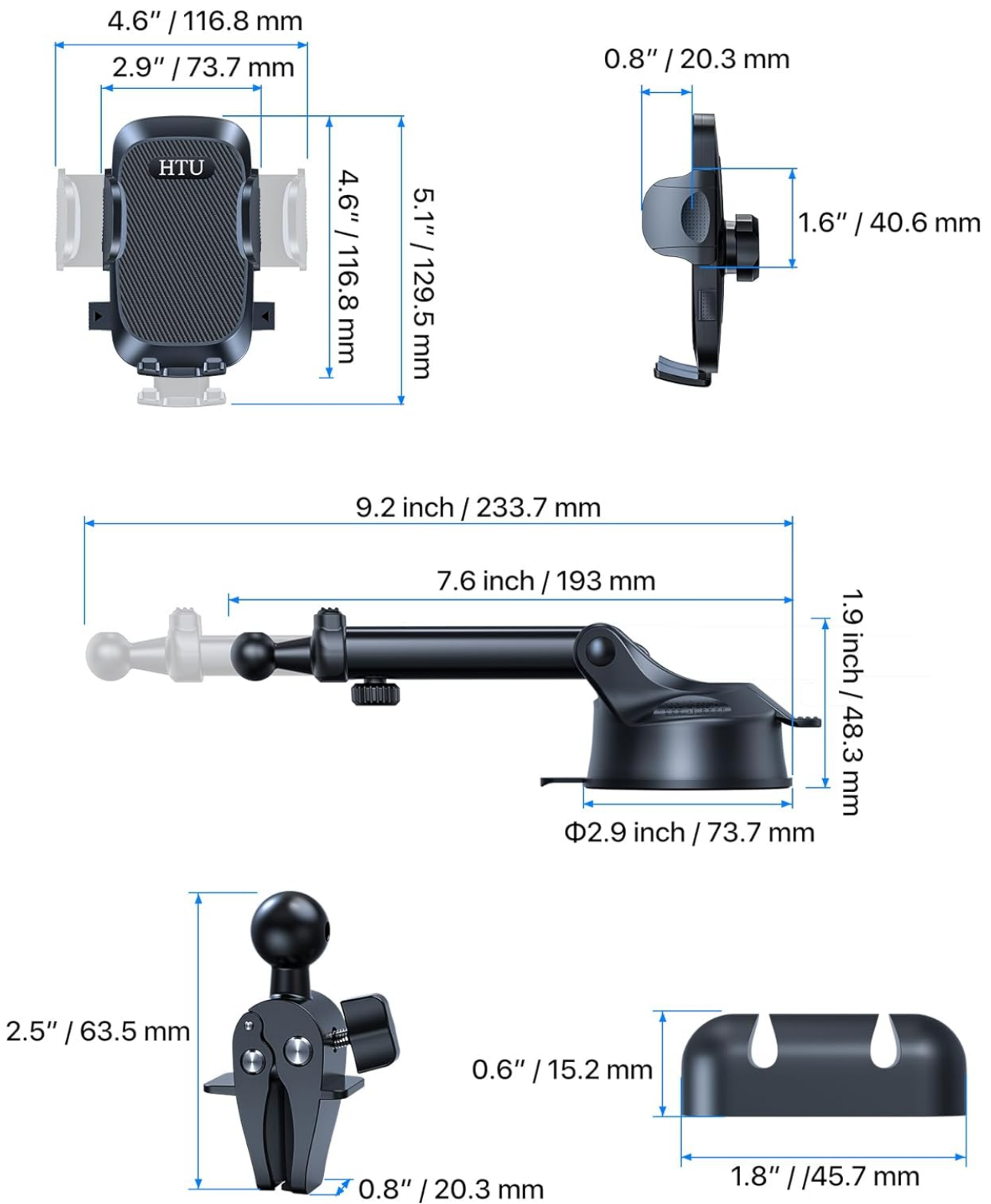

Figure 7.1: Product Dimensions

## 8. WARRANTY AND SUPPORT

The HTU Car Phone Holder Model BS-G126 comes with a 5-year support period, including refund or replacement options. For any inquiries or assistance, please contact HTU customer service.

