



[Manuals.plus](#) /

› [Creole Feast](#) /

› Creole Feast SBK0801 80 Qt Seafood Boiling Kit User Manual

Creole Feast SBK0801

Creole Feast SBK0801 80 Qt Seafood Boiling Kit User Manual

Model: SBK0801

[Introduction](#)

[Safety Information](#)

[Package Contents](#)

[Assembly](#)

[Operation](#)

[Care & Maintenance](#)

[Troubleshooting](#)

[Specifications](#)

[Warranty & Support](#)

1. INTRODUCTION

This manual provides essential instructions for the safe assembly, operation, and maintenance of your Creole Feast SBK0801 80 Qt Seafood Boiling Kit. This kit is designed for outdoor seafood boiling, offering a robust solution for preparing large quantities of seafood and vegetables.

The kit includes an 80-quart boil pot, a 48-quart capacity basket, a high-powered 100,000 BTU propane burner, and a 10 PSI regulator. Please read this manual thoroughly before initial use to ensure proper function and safety.



Figure 1: Creole Feast SBK0801 80 Qt Seafood Boiling Kit components.

2. SAFETY INFORMATION

WARNING: Failure to follow these instructions could result in fire, explosion, or burns, which could cause property damage, personal injury, or death.

- **Outdoor Use Only:** This appliance is designed for outdoor use only. Do not operate indoors or in enclosed spaces.
- **Not for Frying Turkey:** This appliance is specifically designed for boiling and is **NOT** suitable for frying turkeys or other large items in oil.
- **Wear Protective Gear:** Always wear high heat-resistant gloves when handling the pot, basket, or any hot surfaces during and after operation.
- **Stable Surface:** Place the boiling kit on a level, stable, non-combustible surface away from any flammable materials, structures, or vegetation.

- **Propane Tank Safety:**

- Use only a standard 20 lb (9 kg) propane cylinder (LP gas tank) with an OPD (Overfill Protection Device) valve.
- Ensure the propane tank is placed on a stable surface and is not exposed to direct sunlight or excessive heat.
- Check all gas connections for leaks using a soapy water solution before each use. Never use an open flame to check for leaks.
- Keep the propane hose away from hot surfaces.

- **Supervision:** Never leave the boiling kit unattended while in use. Keep children and pets away from the appliance.

- **Hot Surfaces:** The pot, burner, and stand will become extremely hot during operation. Allow ample time for cooling before handling or storing.

- **Water Level:** Ensure the pot is filled with sufficient water before lighting the burner. Never heat an empty pot.

- **Emergency Procedures:** In case of a gas leak, fire, or other emergency, immediately turn off the propane supply, move away from the appliance, and call emergency services.

3. PACKAGE CONTENTS

Verify that all components are present and undamaged before assembly. If any parts are missing or damaged, do not proceed with assembly and contact customer support.

1. 80 Qt Aluminum Pot with Lid
2. 48 Qt Aluminum Basket with Handle
3. Heavy-Duty Steel Stand
4. Propane Burner Assembly (100,000 BTU)
5. 10 PSI Regulator with Hose
6. Electronic Ignition System
7. Hardware Pack (screws, nuts, washers)
8. Instruction Manual

80 QT SEAFOOD BOILER



Figure 2: Key features and components of the boiling kit.

4. ASSEMBLY INSTRUCTIONS

Assembly typically takes about 15-20 minutes. You will need a Phillips head screwdriver (not included) and the included wrench.

- 1. Unpack Components:** Carefully remove all parts from the packaging and lay them out on a clean, flat surface. Ensure all listed package contents are present.
- 2. Assemble the Stand:**
 - Attach the four legs to the main burner support frame using the provided screws and nuts.
 - Secure the bottom shelf to the legs.
 - **Tip:** Do not fully tighten all screws until the stand is approximately 90% assembled. This allows for easier alignment of parts. Once all parts are in place, tighten all fasteners securely.
- 3. Install Burner Assembly:**
 - Mount the burner assembly to the underside of the stand, ensuring the burner head is centered within the stand's opening.
 - Attach the electronic ignitor mechanism to the designated spot on the stand, typically near the

bottom of the control panel, to prevent heat exposure during prolonged use.

4. Connect Regulator and Hose:

- Connect the regulator hose to the burner assembly. Ensure a tight, secure connection.
- The other end of the hose will connect to your propane tank.

5. **Final Check:** Double-check all connections and ensure the stand is stable.

HEAVY-DUTY POT STAND

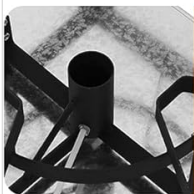
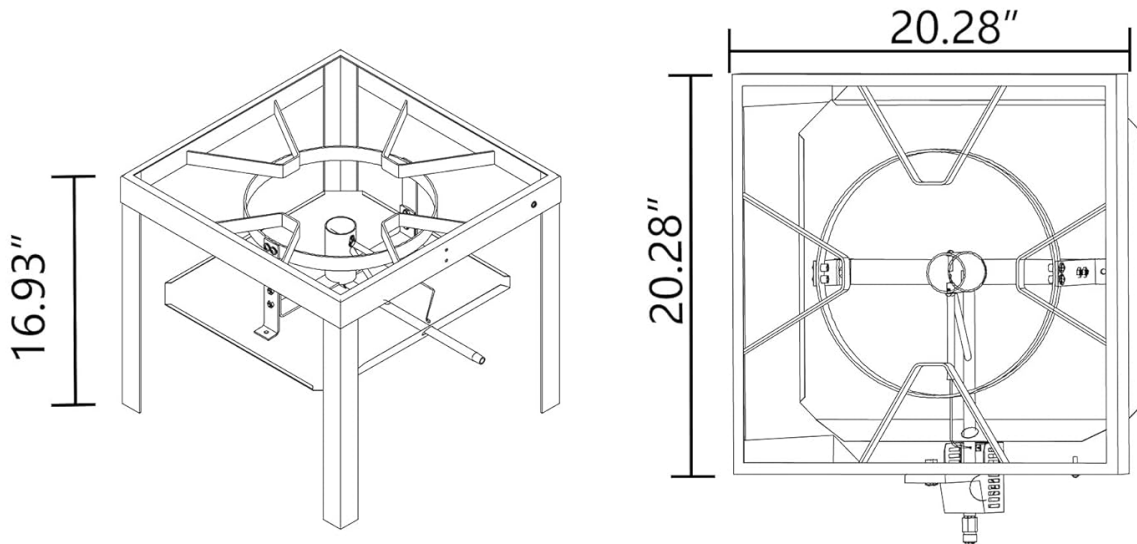

High-powered Jet Burner
100,000 BTU



Bottom Electronic Ignitor
Sure Spark System



Gas Regulator
10 PSI



All-welded Steel Frame

Figure 3: Detailed view of the burner stand and components.



Figure 4: Left: High-powered jet burner flame. Right: Electronic ignitor button.

5. OPERATING INSTRUCTIONS

Follow these steps for safe and effective operation of your seafood boiling kit.

1. **Positioning:** Place the assembled boiling kit on a flat, stable, non-combustible surface outdoors, away from any flammable materials.
2. **Connect Propane Tank:** Connect the regulator hose to a 20 lb (9 kg) propane cylinder. Hand-tighten the connection.
3. **Leak Test:** Before lighting, perform a leak test. Mix soapy water (50% soap, 50% water) and apply it to all gas connections. Open the propane tank valve slowly. If bubbles appear, there is a leak. Close the tank valve immediately and tighten connections. Repeat the test. If leaks persist, do not use the appliance and contact customer support.
4. **Fill Pot:** Place the 80 Qt pot onto the stand. Fill the pot with water to the desired level, ensuring it is sufficient for your ingredients but not overfilled. The 48 Qt basket can hold up to 45 lbs of seafood.
5. **Light the Burner:**
 - Ensure the burner control knob on the regulator is in the "OFF" position.
 - Slowly open the valve on the propane tank fully.
 - Turn the burner control knob to a low setting.
 - Press and hold the electronic ignitor button until the burner lights. If it doesn't light within 5 seconds, turn off the gas, wait 5 minutes, and repeat.
 - Adjust the flame to the desired intensity using the control knob. The 100,000 BTU burner heats water quickly.
6. **Boiling Seafood:**
 - Once the water is boiling, carefully place your seafood and vegetables into the 48 Qt basket.
 - Using high heat-resistant gloves, slowly lower the basket into the boiling water.
 - Place the lid on the pot. The integrated lid hook allows for convenient placement of the lid on the side of the pot when not in use.
 - Boiling times will vary depending on the type and quantity of seafood. The kit can boil up to 45 lbs of seafood in approximately 30 minutes.
7. **Draining:**
 - Once cooking is complete, use high heat-resistant gloves to carefully lift the basket from the pot.
 - Utilize the hang-to-drain slot on the pot to rest the basket and allow excess water to drain.
 - Carefully empty the contents of the basket onto a serving surface.
8. **Shut Down:**
 - Turn the burner control knob to the "OFF" position.
 - Close the valve on the propane tank completely.
 - Allow the entire unit to cool down completely before cleaning or storing.



Figure 5: Lifting the basket after boiling.



Figure 6: Draining and serving cooked seafood.

6. CARE AND MAINTENANCE

Proper care and maintenance will extend the life of your Creole Feast Seafood Boiling Kit.

- **Cleaning the Pot and Basket:**

- Allow the pot and basket to cool completely before cleaning.
- Wash with warm, soapy water and a non-abrasive sponge or cloth.
- Rinse thoroughly and dry completely to prevent water spots and corrosion.
- For stubborn food residue, soak the pot and basket in warm soapy water before scrubbing.

- **Cleaning the Stand and Burner:**

- Ensure the burner and stand are cool.
- Wipe down the stand with a damp cloth.
- Inspect the burner for any blockages (e.g., insect nests). Clean with a soft brush if necessary.
- Do not immerse the burner assembly or regulator in water.

- **Storage:**

- Store the boiling kit in a dry, protected area when not in use.
- Disconnect the propane tank and store it upright in a well-ventilated area, away from direct sunlight or heat sources.
- Consider covering the kit with a weather-resistant cover if storing outdoors.
- **Regular Inspection:** Periodically inspect the hose and connections for signs of wear, cracks, or damage. Replace any damaged components immediately.

7. TROUBLESHOOTING

Problem	Possible Cause	Solution
Burner does not light with ignitor.	Propane tank valve closed. Low propane level. Ignitor electrode dirty or misaligned. Gas flow blockage.	Open propane tank valve fully. Check propane tank level; replace if empty. Clean or adjust ignitor electrode. Inspect burner for obstructions; clear if found.
Low flame or inconsistent flame.	Low propane level. Regulator bypass activated. Burner ports clogged.	Check propane tank level; replace if empty. Turn off all gas, disconnect regulator, wait 30 seconds, reconnect, and slowly open tank valve. Clean burner ports with a wire brush.
Gas odor detected.	Gas leak. Loose connections.	Immediately turn off propane tank valve. Perform a leak test with soapy water. Tighten connections. If odor persists or leak cannot be stopped, do not use and contact emergency services.

8. SPECIFICATIONS

Feature	Detail
Model Number	SBK0801
Pot Capacity	80 Quarts
Basket Capacity	48 Quarts (up to 45 lbs seafood)
Burner BTU	100,000 BTU
Regulator Pressure	10 PSI
Product Dimensions (assembled)	20.28 x 20.28 x 33.07 inches (L x W x H)

Feature	Detail
Item Weight	32.8 pounds
Material	Aluminum Pot & Basket, Steel Stand
Ignition Type	Electronic Ignition
Power Source	Propane Gas (LP)



Figure 7: Product dimensions.

9. WARRANTY AND SUPPORT

Creole Feast products are manufactured with quality and performance in mind. For specific warranty details, please refer to the warranty card included with your product or visit the official Creole Feast website. If you have any questions, require technical assistance, or need to order replacement parts, please contact Creole Feast customer support.

Manufacturer: Royal Gourmet Corp

For the most up-to-date support information, please visit the [Creole Feast Store on Amazon](#).

