



Manuals.plus /

- › COBI /
- › COBI Historical Collection Messerschmitt Me 262A-1A Building Block Model Instruction Manual

## COBI 5721

# COBI Historical Collection Messerschmitt Me 262A-1A

Model Number: 5721

---

## INTRODUCTION

This instruction manual provides detailed guidance for the assembly, operation, and maintenance of your COBI Historical Collection Messerschmitt Me 262A-1A building block model. The Messerschmitt Me 262 was the world's first operational jet-powered fighter aircraft, introduced by Germany during World War II. This COBI model accurately recreates this iconic aircraft using high-quality construction blocks, offering an engaging building experience and a detailed display piece.

Please read these instructions carefully before beginning assembly to ensure a smooth and enjoyable building process.



Image: Front view of the COBI Messerschmitt Me 262A-1A model kit box, showing the assembled aircraft and included pilot figure.

## SAFETY INFORMATION

This product contains small parts and is recommended for ages 6-13 years. Adult supervision is advised for younger builders. Keep small parts away from children under 3 years of age to prevent choking hazards. Always follow the assembly instructions provided in the box.

## PACKAGE CONTENTS

Upon opening the box, please verify that all components are present. The COBI Messerschmitt Me 262A-1A model kit includes:

- 390 high-quality construction blocks
- 1 pilot figure
- 1 display stand with name plate
- 1 detailed instruction manual (this document refers to the physical manual included in the box)

If any parts are missing or damaged, please refer to the 'Warranty and Support' section for assistance.

## ASSEMBLY INSTRUCTIONS

The assembly of the Messerschmitt Me 262A-1A model is guided by the comprehensive, step-by-step graphical instruction manual included in your kit. Each step is clearly illustrated with icons and drawings to facilitate the building process.

1. **Unpack Components:** Carefully open all bags containing the building blocks. It is recommended to sort the blocks by color or type to simplify the assembly process.
2. **Follow the Manual:** Refer to the included physical instruction manual. Each step shows which blocks are needed and how they connect. Pay close attention to the orientation of the blocks.
3. **Secure Connections:** Ensure all blocks are firmly pressed together to create a stable and durable model.
4. **Pilot Figure Assembly:** Assemble the pilot figure as shown in the manual.
5. **Display Stand Assembly:** Assemble the display stand and attach the name plate.

The COBI blocks are designed for a precise fit and are fully compatible with other leading brands of construction blocks, allowing for creative expansion if desired.



Image: The fully assembled COBI Messerschmitt Me 262A-1A model, including the pilot figure and its dedicated display stand.

## OPERATING THE MODEL

Once assembled, your Messerschmitt Me 262A-1A model features several interactive elements:

- **Movable Cockpit Canopy:** The cockpit canopy can be opened to place or remove the pilot figure.
- **Retractable Landing Gear:** The landing gear can be manually retracted or extended, allowing for display in either flight or landing configuration.
- **Movable Flaps:** The wing flaps can be adjusted, adding to the realism of the model.

The included display stand allows for a stable presentation of the aircraft, highlighting its design and historical significance.



Image: A detailed view of the Messerschmitt Me 262A-1A cockpit, showing the open canopy and interior.

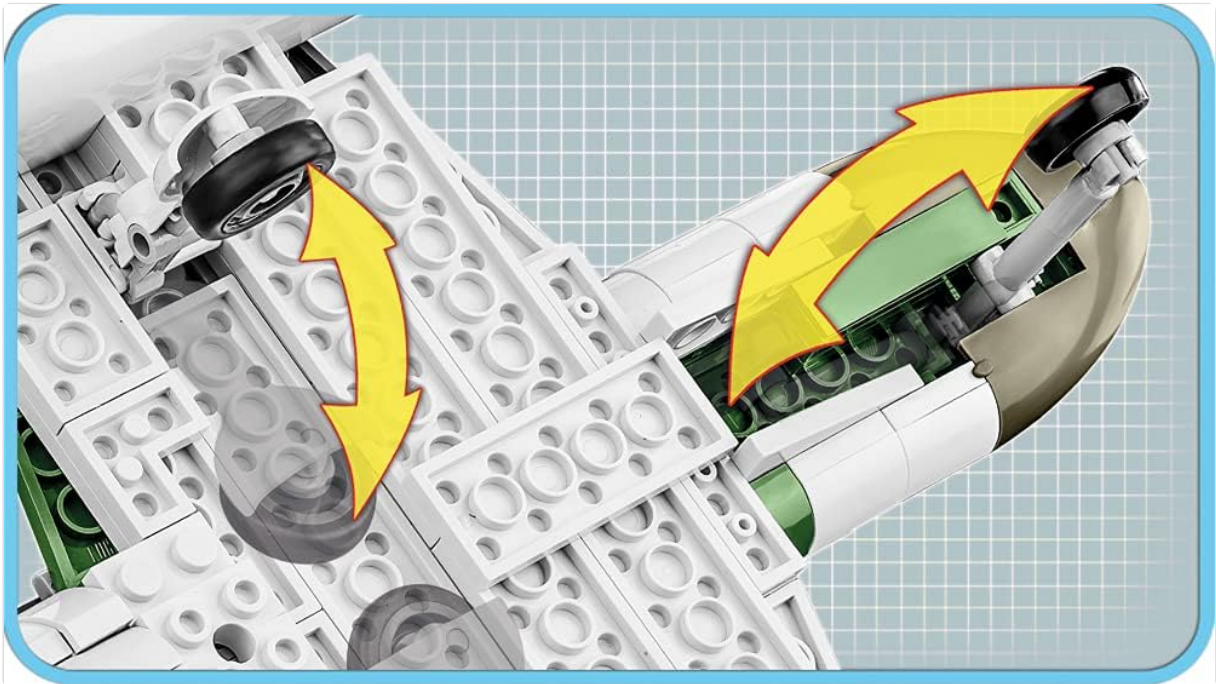

Image: A close-up illustrating the retractable landing gear mechanism on the underside of the aircraft.

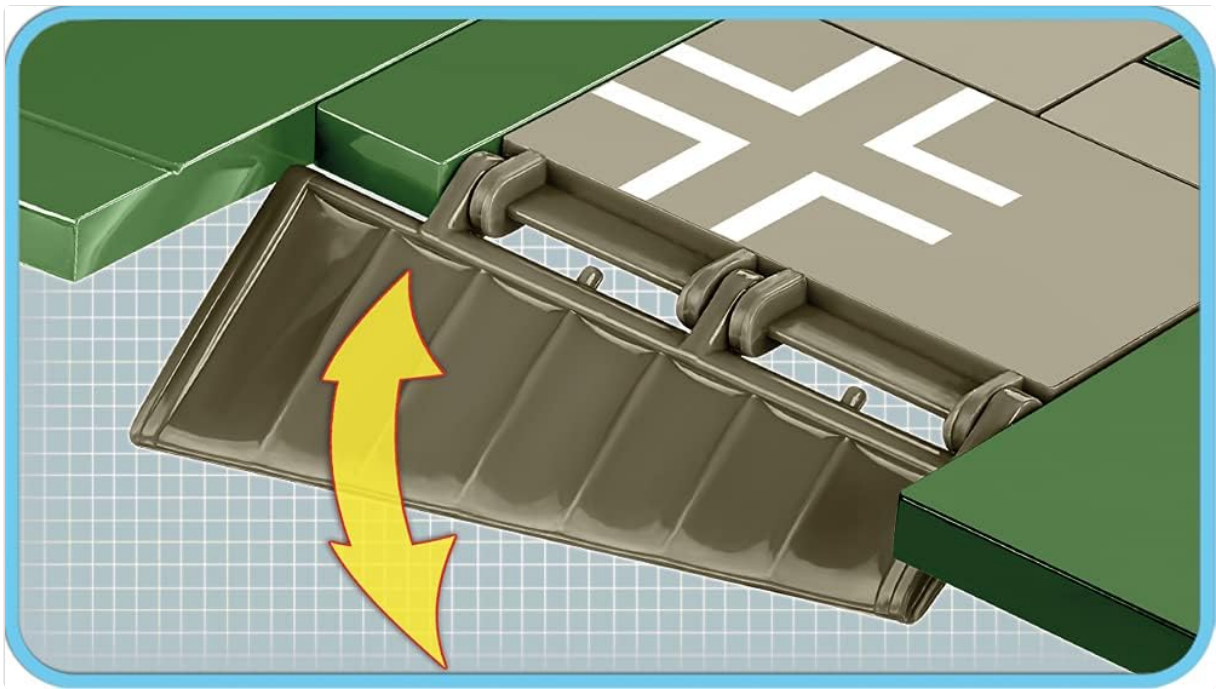

Image: A detailed view of the movable wing flaps on the COBI Messerschmitt Me 262A-1A model.

Your browser does not support the video tag.

Video: An overview of the COBI Messerschmitt Me 262A-1A model, showcasing its features and design.

## MAINTENANCE

To ensure the longevity and appearance of your COBI model, follow these simple maintenance guidelines:

- **Cleaning:** Dust the model regularly with a soft, dry cloth or a soft brush. For more stubborn dirt, lightly dampen a cloth with water (no harsh chemicals) and gently wipe the affected areas.
- **Storage:** Store the model in a cool, dry place away from direct sunlight to prevent discoloration or warping of the plastic blocks.
- **Handling:** Handle the model carefully, especially when moving it, to avoid accidental disassembly of parts.

## TROUBLESHOOTING

While COBI models are designed for high quality and ease of assembly, you might encounter minor issues. Here are some common troubleshooting tips:

- **Missing Parts:** If you believe a part is missing, double-check all packaging and the surrounding area. Sometimes small pieces can be overlooked. If still missing, contact COBI customer support as detailed in the 'Warranty and Support' section.
- **Difficulty Connecting Blocks:** Ensure blocks are correctly oriented and aligned. Apply firm, even pressure. If a connection feels unusually tight, verify you are using the correct pieces as per the manual.
- **Model Instability:** Re-examine the connections in the unstable section. Loose connections are often the cause. Ensure all blocks are fully seated.

## SPECIFICATIONS

Key specifications for the COBI Messerschmitt Me 262A-1A model (Model 5721):

| Feature                        | Detail  |
|--------------------------------|---|
| Model Number                   | 5721  |
| Number of Blocks               | 390   |
| Product Dimensions (assembled) | Approximately 32.5 cm (12.8 inches) length, 11.5 cm (4.5 inches) height |
| Item Weight                    | 1.56 pounds   |
| Manufacturer Recommended Age   | 6 - 13 years  |
| Release Date                   | September 13, 2022  |
| Compatibility                  | Fully compatible with other brands of construction blocks               |



Image: Side profile of the assembled model showing its length (32.5cm / 12.8") and height (11.5cm / 4.5").



# MESSERSCHMITT ME 262A-1A



**PLACE OF ORIGIN - GERMANY**

**IN SERVICE - 1944 - 1945**

**ROLE - FIGHTER / FIGHTER BOMBER**

**CREW - 1**

**WINGSPAN - 12,6M (41' - 4")**

**LENGTH - 10,6M (34' - 9")**

**HEIGHT - 3,5M (11' - 5")**

**MAXIMUM WEIGHT - 6100KG (13448,2LB)**

**ENGINE - 2x JUNKERS JUMO 004 B-1**

**TURBOJETS 8,8KN (900KP) THRUST EACH**

**RANGE - 1050KM (652MI)**

**RATE OF CLIMB - 20M/S (3,900FT/MIN)**

**MAXIMUM FLIGHT LEVEL - 1200M (39370FT)**

**SPEED - 870KM/H (541MPH)**

**ARMAMENT - 4x 30MM (1.18") CANNON**

Image: A graphic detailing historical specifications of the Messerschmitt Me 262A-1A aircraft, including wingspan, length, engine type, and armament.

## WARRANTY AND SUPPORT

COBI is committed to providing high-quality construction blocks and an excellent building experience. If you encounter any issues with your product, such as missing or defective parts, or require further assistance with assembly, please contact COBI customer support. Refer to the contact information provided on the product packaging or the official COBI website for the most up-to-date support channels.

COBI products are produced in the EU by a company with over 20 years of tradition in creating quality construction blocks, ensuring a reliable and enjoyable product.