

EARUMZDQ 769282788210

EARUMZDQ 4-20MA Output Integral Level Transmitter User Manual

Model: 769282788210

Brand: EARUMZDQ

1. PRODUCT OVERVIEW

The EARUMZDQ 4-20MA Output Integral Level Transmitter is designed for precise and stable liquid level measurement. Constructed from 304 stainless steel, it offers excellent anti-corrosion performance and durability for various liquid applications, including oil and water. Its robust design ensures high accuracy and reliability.

Key Features:

- **Stable Design:** Features anti-bending properties, high accuracy, high stability, and an anti-blocking hole design for easy cleaning.
- **Premium Quality:** Utilizes anti-corrosion materials, primarily 304 stainless steel, ensuring durability and longevity.
- **Operational Range:** Suitable for detecting liquid levels within a 0-5 meter range.
- **Output:** Provides a standard 4-20mA transmission output, compatible with digital displays, PLCs, inverters, and recorders.
- **Power Supply:** Operates on a DC 10-30V power supply.
- **Cable:** Includes a 6-meter waterproof cable for flexible installation.
- **Performance:** Equipped with reverse polarity and current limit protection, laser-proof temperature compensation, and programmable adjustment capabilities.



Figure 1: EARUMZDQ 4-20MA Output Integral Level Transmitter with cable.

This image displays the complete level transmitter unit, featuring the stainless steel probe and the coiled 6-meter cable with exposed wires for electrical connection.

2. SPECIFICATIONS

Technical Specifications

Feature	Detail
Model Number	769282788210
Measurement Range	0-5 meters (0-5M)
Output Signal	4-20mA
Power Supply	DC 10-30V

Feature	Detail
Cable Length	6 meters
Probe Material	304 Stainless Steel
Product Dimensions	12 x 7.5 x 1 inches (packaged)
Item Weight	1.54 Pounds



Figure 2: Key dimensions of the level transmitter probe.

This image illustrates the physical dimensions of the sensor probe, showing a length of 110mm, a diameter of 27mm, and a cable connection length of 49mm.

3. SAFETY INFORMATION

Adhering to safety guidelines is crucial for preventing injury and damage to the equipment. Please read and understand the following precautions:

- **Power Disconnection:** Always ensure the power supply is disconnected before performing any installation, wiring, or maintenance tasks.
- **Voltage and Current:** Do not exceed the specified DC 10-30V power supply range or the 4-20mA current limits. Incorrect voltage can damage the sensor.
- **Physical Protection:** Avoid subjecting the sensor probe or cable to physical impact, bending, or abrasion. Protect the cable from sharp edges and excessive tension.
- **Qualified Personnel:** Installation and wiring should ideally be performed by qualified and experienced personnel familiar with electrical systems and liquid level sensing equipment.
- **Environmental Use:** Do not use this sensor in explosive, flammable, or otherwise hazardous environments unless it is specifically certified for such applications.
- **Liquid Compatibility:** Ensure the sensor's 304 stainless steel construction is compatible with the liquid being measured to prevent corrosion or damage.

4. SETUP AND INSTALLATION

4.1 Unpacking and Inspection

Carefully remove the level transmitter from its packaging. Inspect the sensor probe, cable, and connections for any signs of shipping damage or manufacturing defects. If any damage is found, do not proceed with installation and contact customer support.

4.2 Mounting the Sensor

The sensor is designed for submersible applications. For accurate readings, the probe must be suspended vertically in the liquid to be measured. Ensure the sensor is positioned such that its entire measurement range (0-5 meters) can be utilized within the liquid container or tank.

- Secure the cable at the top of the tank or container to prevent strain on the sensor connection and to maintain the probe's vertical alignment.
- Avoid placing the sensor near inlets or outlets where turbulence could affect readings.



Figure 3: Level transmitter probe submerged in liquid.

This image demonstrates the sensor probe partially submerged in water, indicating its typical operational environment for liquid level detection.

4.3 Wiring Diagram and Connections

The sensor utilizes a 2-wire current output (4-20mA). Connect the sensor to your power supply and receiving device (e.g., PLC, digital display) according to the following instructions and diagram:

- **Red Cable (V+):** Connect this wire to the positive (+) terminal of your DC 10-30V power supply.
- **Black Cable (V-):** Connect this wire to the negative (-) terminal of your DC 10-30V power supply. This wire also serves as the signal return and should be connected to the input of your receiving device (e.g., the 'A' terminal for current input).

WIRING DIAGRAM

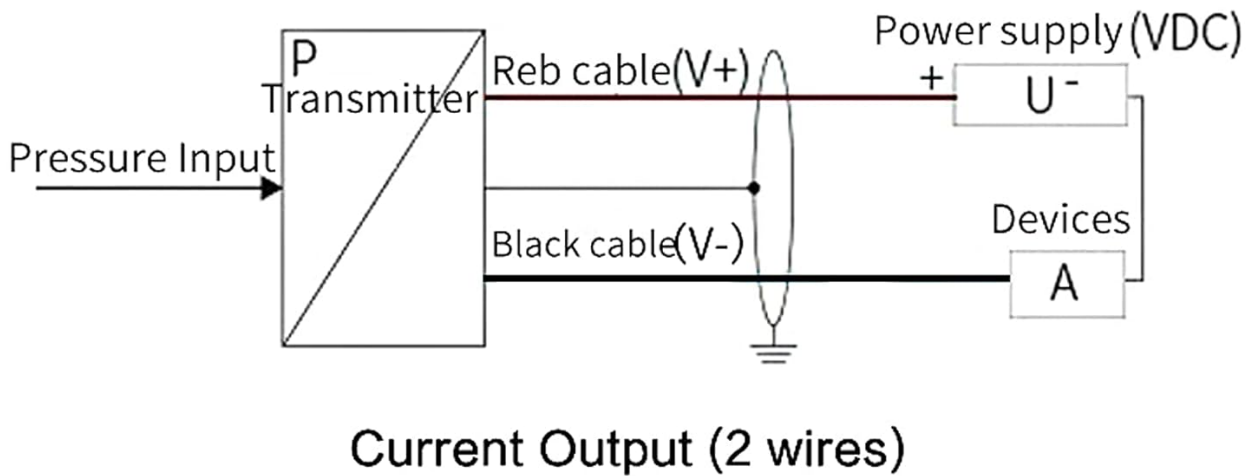

Current Output (2 wires)

Figure 4: Two-wire current output wiring diagram.

This diagram illustrates the electrical connections for the 2-wire current output sensor. The red cable (V+) connects to the positive power supply, and the black cable (V-) connects to the negative power supply and the device input (A).



Figure 5: Exposed cable ends for wiring.

This image shows the stripped ends of the sensor's cable, revealing the red (V+) and black (V-) wires ready for electrical connection.

Important: Always ensure correct polarity and that the power supply voltage is within the specified DC 10-30V range to prevent irreversible damage to the sensor.

5. OPERATION

Once the level transmitter is correctly installed and wired, it will continuously measure the liquid level and transmit a proportional 4-20mA current signal. This signal can then be interpreted by a connected receiving device.

- **Minimum Level (0 meters):** Corresponds to a 4mA output signal.
- **Maximum Level (5 meters):** Corresponds to a 20mA output signal.
- **Intermediate Levels:** Any liquid level between 0 and 5 meters will produce a current output proportionally scaled between 4mA and 20mA.

Connecting to a Display or Controller:

The 4-20mA output signal is a standard industrial signal that can be connected to various control and monitoring

devices. These include:

- Digital displays for local level indication.
- Programmable Logic Controllers (PLCs) for automated control systems.
- Inverters for pump control based on liquid level.
- Data recorders for logging historical level data.

Refer to the instruction manual of your specific receiving device for details on its 4-20mA input requirements, scaling, and configuration.

6. MAINTENANCE

Regular maintenance is essential to ensure the optimal performance, accuracy, and extended lifespan of your level transmitter.

- **Cleaning the Probe:** Periodically inspect the sensor probe for any accumulation of dirt, debris, sludge, or scale. If buildup is present, gently clean the probe surface with a soft cloth and a cleaning solution compatible with 304 stainless steel and the measured liquid. The anti-blocking hole design assists in preventing severe blockages. Ensure no abrasive materials are used that could scratch the sensor surface.
- **Cable and Connection Inspection:** Regularly check the entire length of the cable for any signs of wear, cuts, cracks, or insulation damage. Verify that all electrical connections are secure, tight, and free from corrosion. Damaged cables or loose connections can lead to intermittent readings or complete signal loss.
- **Calibration Verification:** If you suspect inaccuracies or drift in readings, perform a calibration check. This involves comparing the sensor's output against known liquid levels. If significant deviations are observed, recalibration or professional servicing may be required.
- **Environmental Monitoring:** Ensure the operating environment (temperature, pressure, chemical exposure) remains within the sensor's specified limits. Extreme conditions can affect performance and durability.

7. TROUBLESHOOTING

This section provides solutions to common issues encountered during the operation of the level transmitter.

Troubleshooting Guide

Problem	Possible Cause	Solution
No output or incorrect 4-20mA signal	<ul style="list-style-type: none">◦ Incorrect wiring◦ No power supply or incorrect voltage◦ Sensor damage◦ Heavy buildup on sensor probe	<ul style="list-style-type: none">◦ Verify wiring against the diagram (Figure 4).◦ Check power supply (DC 10-30V) and ensure all connections are secure.◦ Inspect sensor for physical damage; replace if necessary.◦ Clean the sensor probe thoroughly.

Problem	Possible Cause	Solution
Inaccurate or fluctuating readings	<ul style="list-style-type: none"> ◦ Sensor not vertically aligned ◦ Buildup on sensor probe ◦ Turbulence in liquid ◦ Environmental interference (e.g., strong electromagnetic fields) ◦ Sensor requires calibration 	<ul style="list-style-type: none"> ◦ Ensure the probe is suspended vertically and securely. ◦ Clean the sensor probe. ◦ Relocate sensor away from turbulent areas or install a stilling well. ◦ Check for and mitigate sources of electrical interference. ◦ Perform a calibration check against known levels.
Intermittent signal	<ul style="list-style-type: none"> ◦ Loose wiring connections ◦ Damaged cable ◦ Unstable power supply 	<ul style="list-style-type: none"> ◦ Check and secure all wiring connections. ◦ Inspect the cable for damage; replace if necessary. ◦ Ensure a stable and clean power supply.

8. WARRANTY AND SUPPORT

For specific warranty terms and conditions, please refer to the documentation provided at the time of purchase or contact EARUMZDQ customer service. Keep your purchase receipt as proof of purchase.

Product Information for Support:

- **Manufacturer:** EARU ELECTRICAL
- **ASIN:** B09658BFR4
- **Model Number:** 769282788210
- **Date First Available:** May 29, 2021

For further assistance, technical support, or to inquire about replacement parts, please visit the official [EARUMZDQ brand page on Amazon](#) or contact your local distributor.

© 2024 EARUMZDQ. All rights reserved.

This manual is subject to change without prior notice.