

[Manuals.plus](#) /

› [HQRP](#) /

› HQRP Pedestal Sump Pump Float Switch User Manual

HQRP 887774402092111

HQRP Pedestal Sump Pump Float Switch User Manual

Model: 887774402092111

INTRODUCTION

This manual provides essential information for the safe and effective installation, operation, and maintenance of your HQRP Pedestal Sump Pump Float Switch. Please read these instructions thoroughly before use and retain them for future reference. This float switch is designed to provide automatic water level control for pedestal-style sump pumps.

SAFETY INFORMATION

WARNING: Electrical shock hazard. Always disconnect power to the sump pump before installing, servicing, or performing any maintenance on the float switch or pump system.

- This product is UL Listed, indicating compliance with recognized safety standards.
- Rated Current: 15A at 125V; 8A at 250V. Ensure your pump's electrical requirements are within these limits.
- This product may contain chemicals known to the State of California to cause cancer and birth defects or other reproductive harm. Wash hands after handling.
- Installation should be performed by a qualified individual if you are unsure about electrical wiring or plumbing procedures.

PRODUCT OVERVIEW

The HQRP Pedestal Sump Pump Float Switch is a replacement component designed for automatic water level detection in sump pump applications. It features a durable metal switch arm and is engineered for reliable performance.

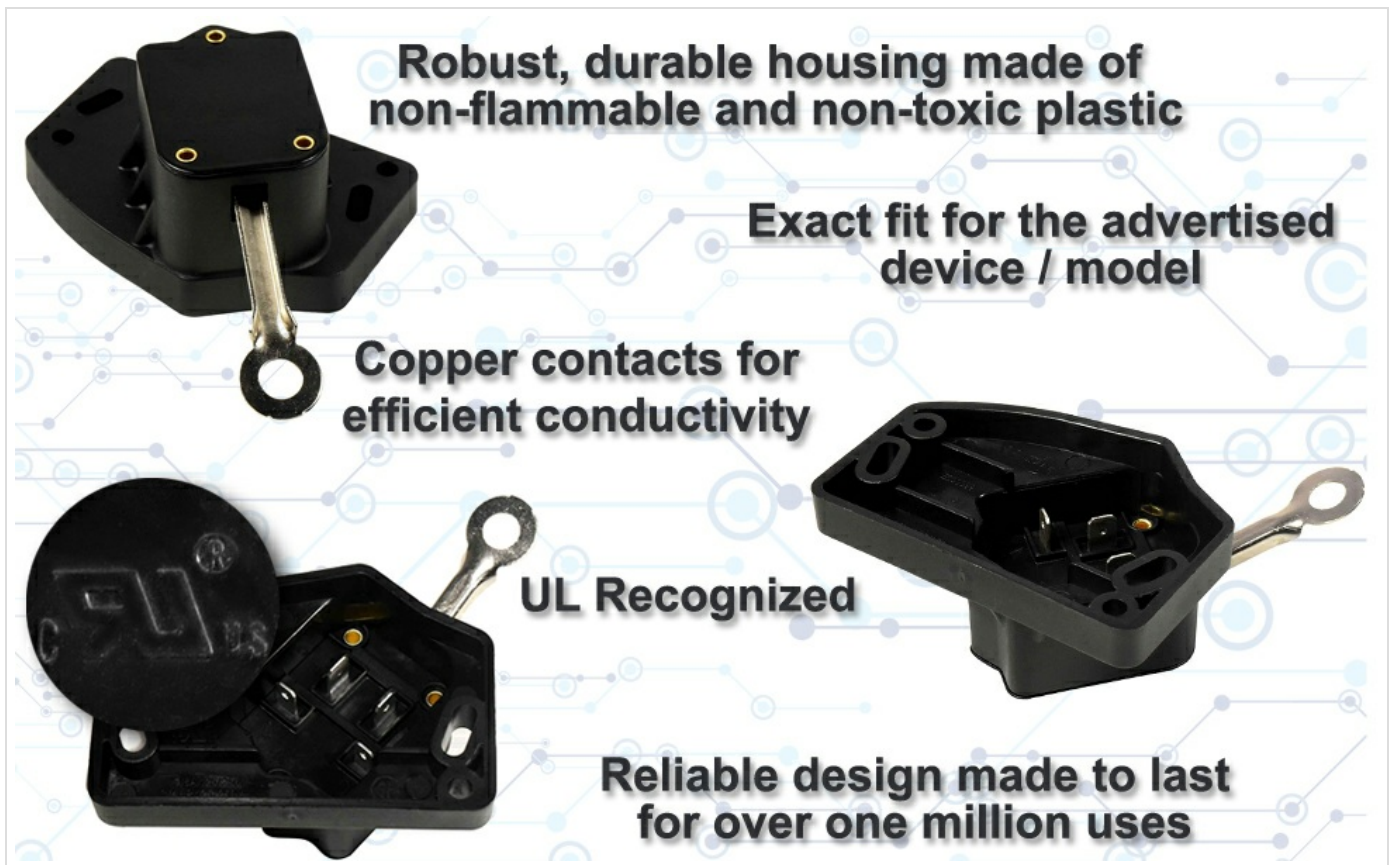

Image: Key features of the HQRP Pedestal Sump Pump Float Switch, highlighting its robust housing, copper contacts for efficient conductivity, UL recognition, and durable design.

Key Features:

- Durable metal switch arm for extended lifespan.
- Robust, non-flammable, and non-toxic plastic housing.
- Copper contacts for efficient electrical conductivity.
- UL Recognized component.
- Designed for over one million uses.

Compatibility:

This float switch is a universal design that replaces most external pedestal pump float switches. It is compatible with models such as Superior Pump 99100, Everbilt, Wayne, Craftsman, and those similar to Home Depot QKS5-05. It is suitable for residential and light commercial pedestal-style sump pump systems.

Note: This is a replacement product and not an Original Equipment Manufacturer (OEM) part. Always verify your pump's specifications and existing float switch type for best fit before purchase and installation.

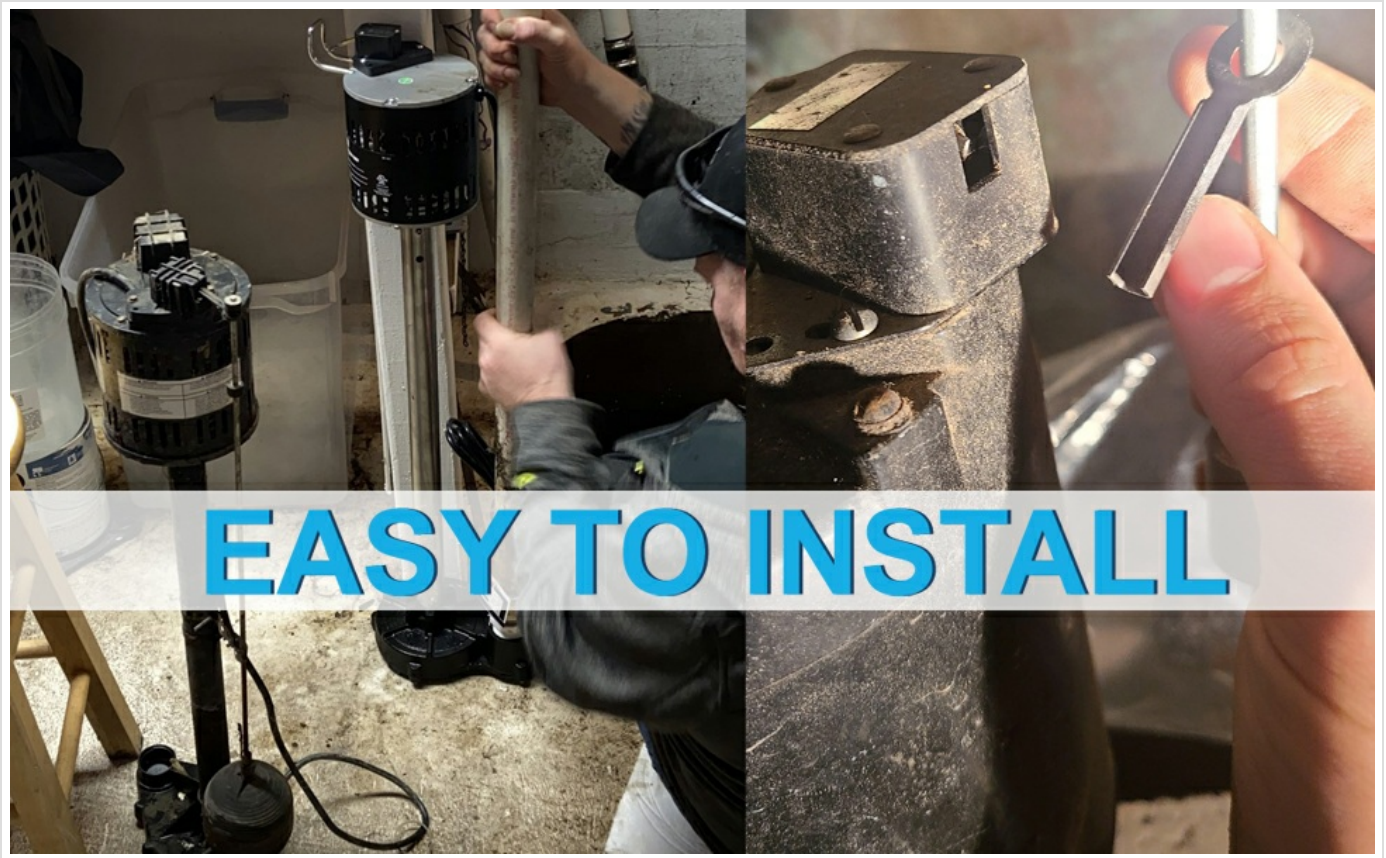

Image: Illustration of wide compatibility with various pedestal sump pump motors.

SETUP AND INSTALLATION

The HQRP Pedestal Sump Pump Float Switch is designed for straightforward installation. Follow these general guidelines:

1. **Disconnect Power:** Ensure the sump pump is completely disconnected from its power source before beginning installation.
2. **Remove Old Switch:** Carefully remove the existing float switch from your pedestal sump pump. Note its mounting position and wiring connections.
3. **Mount New Switch:** Secure the HQRP float switch to the pedestal pump using appropriate hardware. Ensure it is positioned to allow the metal arm to move freely and activate the pump at the desired water level. Refer to the technical drawing for dimensions.

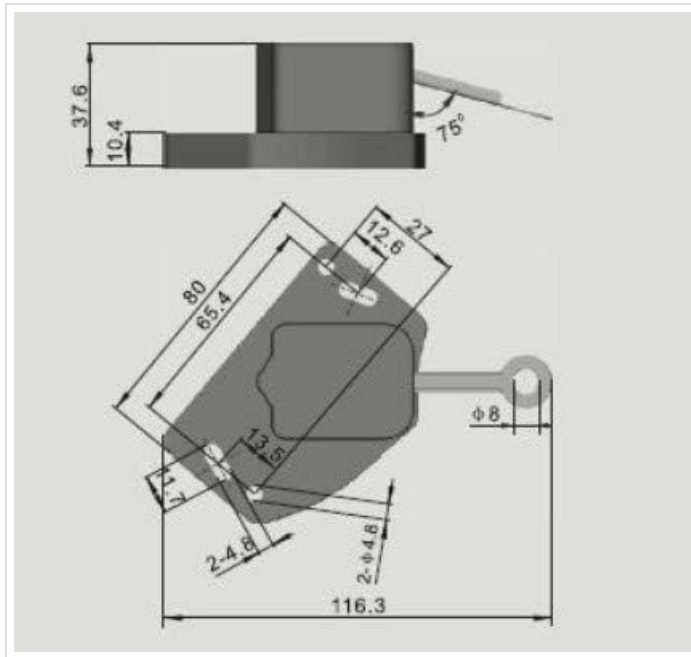

Image: Technical drawing providing dimensions for the HQR Pedestal Sump Pump Float Switch, useful for installation planning.

4. **Wire Connections:** Connect the float switch wiring to the sump pump's electrical system according to the pump manufacturer's instructions. Typically, this involves connecting the switch in series with the pump's power supply.
5. **Test Operation:** Once installed and wired, restore power to the pump. Manually lift the float arm to simulate rising water levels and ensure the pump activates. Lower the arm to ensure the pump deactivates.



Image: A visual guide demonstrating the ease of installing the HQR Pedestal Sump Pump Float Switch.

OPERATING INSTRUCTIONS

The HQR Pedestal Sump Pump Float Switch operates automatically to control your sump pump based on water levels.

- When water levels rise and lift the float arm to a predetermined height, the switch will close, activating the sump pump.

- The pump will then remove water from the sump pit.
- As the water level drops, the float arm will lower. Once it reaches the lower activation point, the switch will open, deactivating the sump pump.

This cycle ensures automatic water removal, preventing basement flooding.

MAINTENANCE

Regular inspection of your sump pump system, including the float switch, is recommended to ensure proper function.

- Periodically check the sump pit for debris that could obstruct the float switch's movement.
- Ensure the float arm moves freely without any interference.
- Test the pump's operation by pouring water into the sump pit to observe the float switch activating and deactivating the pump.

TROUBLESHOOTING

If your sump pump is not operating as expected, consider the following:

- **Pump Not Activating:**
 - Check if the float switch is obstructed by debris or positioned incorrectly.
 - Verify that the pump is receiving power and that all electrical connections are secure.
 - Ensure the float arm can move freely to the 'on' position.
- **Pump Not Deactivating:**
 - Check for obstructions preventing the float arm from returning to the 'off' position.
 - Ensure the sump pit is draining properly and not holding water at a level that keeps the float engaged.
- **Intermittent Operation:**
 - Inspect wiring for loose connections or damage.
 - Ensure the float switch is securely mounted and not shifting.

If issues persist after checking these points, it is advisable to consult a qualified plumber or electrician.

SPECIFICATIONS

Attribute	Specification
Brand	HQRP
Model Number	887774402092111
UPC	884667800162
Rated Current	15A at 125V; 8A at 250V
Voltage	125 Volts
Material	Metal (arm), Plastic (housing)
Color	Black
Item Weight	0.04 Kilograms (1.44 ounces)
Power Source	Battery Powered (refers to the pump it controls, not the switch itself)

Certifications	UL Listed
----------------	-----------

WARRANTY

This HQRP Pedestal Sump Pump Float Switch comes with a 200-day warranty from the date of purchase. Please retain your proof of purchase for warranty claims.

SUPPORT

For further assistance, technical inquiries, or warranty support, please contact HQRP customer service or the retailer from whom the product was purchased. You may also visit the official HQRP website for additional resources.



© 2023 HQRP. All rights reserved. All brand names and logos are registered trademarks of their respective owners. Any use of brand names or model designations for this product is made solely for purposes of demonstrating compatibility.