



Manuals.plus /

› RECOIL /

› Recoil S2P-38 Busbar Dual 3/8" (M10) Studs Power Distribution Block Instruction Manual

RECOIL S2P-38

Recoil S2P-38 Busbar Dual 3/8" (M10) Studs Power Distribution Block Instruction Manual

Model: S2P-38 | Brand: RECOIL

1. INTRODUCTION

This manual provides essential information for the safe and effective installation, operation, and maintenance of your Recoil S2P-38 Dual 3/8" (M10) Studs Power Distribution Block. Please read these instructions thoroughly before use and retain them for future reference.

2. PRODUCT OVERVIEW

The Recoil S2P-38 Busbar is designed to provide a centralized point for power distribution in various electrical systems, including marine, automotive, and RV applications. It features dual 3/8" (M10) stainless steel studs for secure connections and a reinforced polycarbonate cover for protection against accidental short circuits. The nickel-plated brass plate ensures low resistance and maximum conductivity.



Image: Recoil S2P-38 Busbar with connected wires, illustrating its function as a power distribution point.

3. SPECIFICATIONS

Feature	Detail
Model Number	S2P-38
Stud Size	Dual 3/8" (M10) Stainless Steel Studs
Max Voltage	48V DC
Max Continuous Amperage	250A DC
Base Material	Polycarbonate (PC)
Conductor Plate Material	Nickel Plated Brass
Mounting Type	Panel Mount
Item Weight	242 g
Parcel Dimensions	14.2 x 11.6 x 5.4 cm

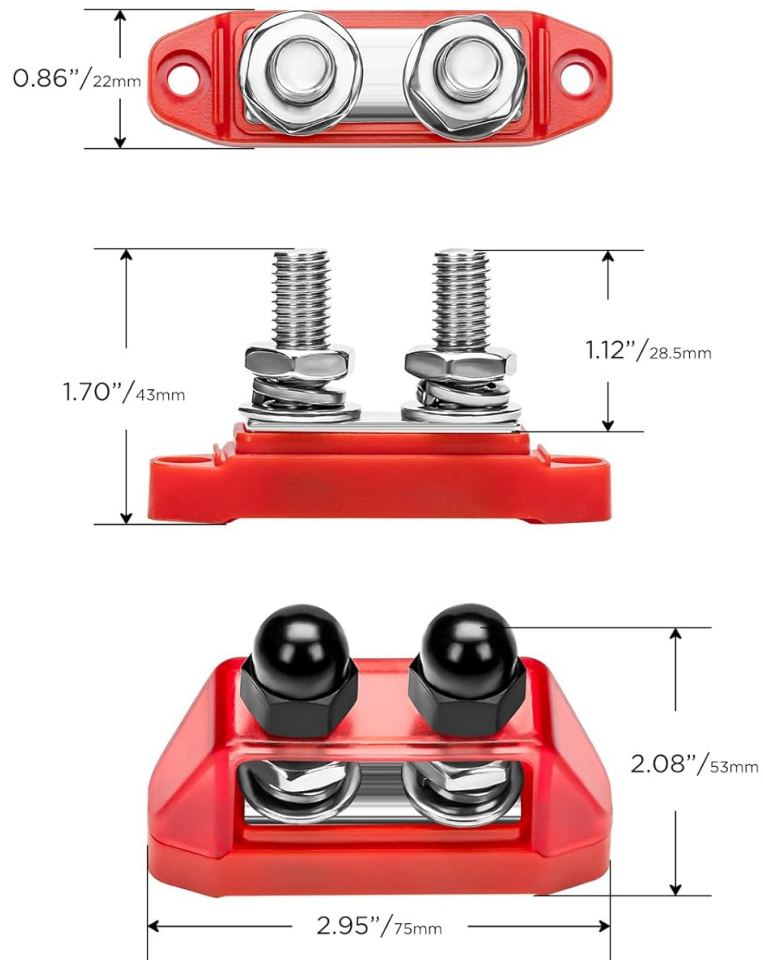

Image: Detailed dimensions of the Recoil S2P-38 Busbar, showing measurements for installation planning.

4. PACKAGE CONTENTS

The Recoil S2P-38 Busbar package includes the following items:

- 2 x Busbars (Red & Black)
- 8 x 8AWG Ring Terminals
- 4 x Stainless-Steel Screws



Image: Contents of the Recoil S2P-38 package, including two busbars (red and black), ring terminals, and mounting screws.

5. SAFETY INFORMATION

WARNING: Electrical systems can be dangerous. Improper installation or use can result in serious injury or damage. Always consult with a qualified professional if you are unsure about any part of the installation process.

- Always disconnect the power source (e.g., battery) before installing or servicing the busbar.
- Wear appropriate personal protective equipment (PPE), including safety glasses and insulated gloves.
- Ensure all connections are tight and secure to prevent arcing and overheating.
- Do not exceed the maximum voltage (48V DC) or continuous amperage (250A DC) ratings.
- Install the busbar in a dry, protected location away from flammable materials.
- The polycarbonate cover must be securely attached after installation to prevent accidental short circuits.

6. SETUP AND INSTALLATION

Follow these steps for proper installation of your Recoil S2P-38 Busbar:

1. **Choose a Mounting Location:** Select a flat, stable surface for mounting the busbar. Ensure it is easily accessible for wiring but protected from physical damage and moisture.
2. **Mark Mounting Points:** Use the busbar as a template to mark the locations for the four stainless-steel mounting screws.
3. **Drill Pilot Holes:** Drill appropriate pilot holes for the mounting screws.
4. **Secure the Busbar:** Attach the busbar to the chosen surface using the provided stainless-steel screws. Ensure it is firmly secured.
5. **Prepare Wires:** Strip the insulation from your power cables and crimp the provided 8AWG ring terminals onto the ends. Ensure a strong, secure crimp.
6. **Connect Wires:**
 - Loosen the nuts on the 3/8" (M10) studs.
 - Place the ring terminals onto the studs. For multiple connections, stack terminals neatly.
 - Tighten the nuts securely. Do not overtighten, but ensure there is no play in the connection.
7. **Install Protective Cover:** Place the reinforced polycarbonate cover over the studs and secure it with the nylon nuts. This cover protects against accidental contact and short circuits.
8. **Verify Connections:** Double-check all connections for tightness and proper polarity before restoring power.

Gives a neat and clean finish to any installation in your boat, car or caravan.

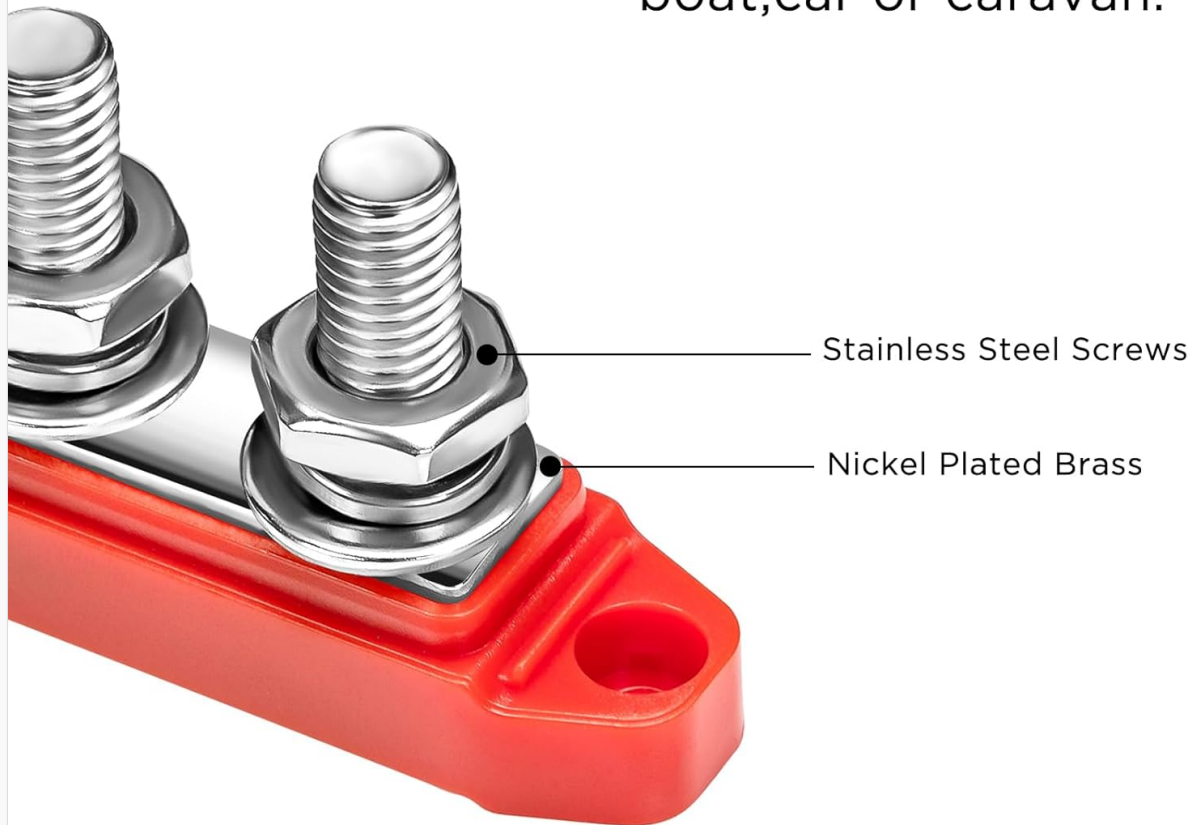

Stainless Steel Screws

Nickel Plated Brass

Image: Close-up view of the nickel-plated brass plate and stainless steel studs, highlighting the robust construction for secure electrical connections.

Installation Video Reference:

Your browser does not support the video tag.

Video: This video demonstrates the installation of a similar dual 3/8" stud busbar, providing visual guidance for connecting wires and securing the unit. (Source: Joinfworld)

Your browser does not support the video tag.

Video: This video illustrates the installation process for a dual stud power distribution block, showing how to connect cables and secure the protective cover. (Source: RED WOLF)

7. OPERATING INSTRUCTIONS

The Recoil S2P-38 Busbar is a passive power distribution component. Its operation involves maintaining secure electrical connections for multiple circuits from a single power source.

- Ensure all connected devices draw current within the busbar's maximum continuous amperage rating (250A DC).
- Regularly inspect connections for any signs of loosening or corrosion.
- The protective cover should always remain in place during operation to prevent accidental contact

with live terminals.

8. MAINTENANCE

Regular maintenance ensures the longevity and safe operation of your busbar:

- **Periodic Inspection:** Annually, or more frequently in harsh environments, inspect the busbar for any signs of corrosion, discoloration, or physical damage.
- **Check Connections:** Verify that all nuts on the studs are tight. Loose connections can lead to resistance, heat buildup, and potential failure.
- **Cleaning:** If necessary, disconnect power and gently clean the busbar and terminals with a dry, non-abrasive cloth. Do not use harsh chemicals or solvents.
- **Cover Integrity:** Ensure the polycarbonate cover is intact and securely fastened. Replace if damaged.

9. TROUBLESHOOTING

If you encounter issues with your power distribution system, consider the following:

- **No Power to Device:**
 - Check the main power source (battery) for charge.
 - Inspect all connections at the busbar and device for tightness.
 - Verify that the wire gauge is appropriate for the current draw.
 - Check any inline fuses or circuit breakers in the circuit.
- **Overheating Connections:**
 - Immediately disconnect power.
 - This usually indicates a loose connection or an overloaded circuit. Tighten all connections.
 - Ensure the total current draw does not exceed the busbar's 250A DC rating.
 - Verify that the wire gauge is sufficient for the current being carried.
- **Corrosion:**
 - Disconnect power.
 - Clean any corrosion with a wire brush and a baking soda solution (for battery terminals) or a specialized electrical contact cleaner.
 - Ensure the busbar is installed in a dry environment.

10. WARRANTY AND SUPPORT

For warranty information or technical support, please refer to the RECOIL official website or contact your retailer. Keep your purchase receipt as proof of purchase.

Manufacturer: RECOIL

Website: RECOIL Store on Amazon