



Manuals.plus /

› Sportsroyals /

› Sportsroyals Power Tower FB-20YTXS01 Instruction Manual

## Sportsroyals FB-20YTXS01

# Sportsroyals Power Tower FB-20YTXS01 Instruction Manual

Model: FB-20YTXS01

Introduction	Safety Information	Package Contents	Assembly	Operation	Maintenance
	Troubleshooting	Specifications	Warranty & Support		

## 1. INTRODUCTION

---

Thank you for choosing the Sportsroyals Power Tower FB-20YTXS01. This instruction manual provides essential information for the safe assembly, operation, and maintenance of your new fitness equipment. Please read this manual thoroughly before use and retain it for future reference.

The Sportsroyals Power Tower is designed for home gym use, offering a stable and versatile platform for various strength training exercises, including pull-ups, dips, leg raises, and push-ups. Its robust construction ensures durability and safety during your workouts.

## 2. SAFETY INFORMATION

---

**WARNING:** Failure to follow these safety instructions may result in serious injury or death.

- Consult a physician before beginning any exercise program.
- Keep children and pets away from the equipment during use.
- Place the power tower on a flat, stable surface. Ensure adequate clearance around the equipment.
- Inspect the equipment for loose parts, wear, or damage before each use. Do not use if damaged.
- Ensure all bolts and nuts are securely tightened before and after each use.
- Do not exceed the maximum weight capacity of 450 lbs (approximately 204 kg).
- Use proper form and controlled movements during exercises. Avoid sudden or jerky motions.
- Wear appropriate athletic clothing and footwear.
- Stop exercising immediately if you feel pain, dizziness, or nausea.

### 3. PACKAGE CONTENTS

---

Carefully unpack all components and verify that you have received all items listed below. If any parts are missing or damaged, please contact Sportsroyals customer support.

- Main Frame Components (Vertical supports, base bars, pull-up bar, dip station arms)
- Backrest and Armrest Pads
- Assembly Hardware (Bolts, nuts, washers, caps)
- Assembly Tools (Wrenches, Allen keys)
- Instruction Manual





*Image 1: Sportsroyals Power Tower FB-20YTXS01. This image shows the fully assembled power tower, including the pull-up bar, dip handles, and backrest.*

## 4. ASSEMBLY INSTRUCTIONS

---

Assembly requires two people and approximately 1-2 hours. Follow the steps carefully. While the included instructions may be general, paying close attention to the diagrams and part types will ensure correct assembly.

1. **Prepare the Area:** Clear a spacious area for assembly. Lay out all components and hardware. It is recommended to organize bolts, nuts, and washers before starting.
2. **Assemble the Base:** Connect the main base bars using the appropriate bolts and washers. Ensure the "H" shaped base is stable. The design features a stable dual-triangle frame with oversized anti-slip pads.

# Reinforced Frame, Holds 450LBS



Image 2: Reinforced Frame and Anti-Slip Pads. This image highlights the 2mm thick steel tubing, stable dual-triangle frame, and oversized anti-slip pads at the base, contributing to the power tower's stability.

3. **Attach Vertical Supports:** Secure the main vertical support beams to the assembled base. Ensure they are oriented correctly.
4. **Install Dip Station and Backrest:** Attach the dip station arms and the backrest support to the vertical beams. The backrest is adjustable with 7 positions and the armrests are inclined at 10 degrees for ergonomic support.



*Image 3: Adjustable Backrest and Inclined Armrests. This image details the 7-position adjustable backrest and the 10-degree inclined armrests, designed for comfort and support during exercises like leg raises.*

5. **Mount Pull-up Bar:** Secure the pull-up bar to the top of the vertical supports. This bar offers multiple grip options: overhand, neutral, and underhand.

## 3 Grips Activate Your Muscles



*Image 4: Multiple Grip Options. This image illustrates the three primary grip positions available on the pull-up bar: overhand, neutral, and underhand, allowing for varied muscle activation.*

- 6. Adjust Height:** The pull-up bar height is adjustable to 6 levels, suitable for users up to 6'6" (approximately 198 cm). Adjust to your preferred height using the quick-release pins.

## 6-levels, Ideal for Heights ≤ 6'6



Image 5: 6-Level Height Adjustment. This image demonstrates the power tower's height adjustment feature, showing how the pull-up bar can be set to six different levels, ideal for various user heights.

- 7. Final Tightening:** Once all components are in place, go back and securely tighten all bolts and nuts. Do not overtighten.
- 8. Stability Check:** Gently shake the assembled power tower to ensure it is stable and does not wobble. Adjust foot covers if necessary to compensate for uneven flooring.

## 5. OPERATING INSTRUCTIONS (EXERCISES)

The Sportsroyals Power Tower allows for a variety of bodyweight exercises. Always warm up before exercising and cool down afterward.

### 5.1. Pull-ups

- Grip the pull-up bar with an overhand, underhand, or neutral grip.
- Hang with arms fully extended.
- Pull your body upwards until your chin clears the bar.
- Lower yourself slowly and with control.

### 5.2. Dips

- Grip the dip handles firmly.
- Lift your body, supporting yourself with straight arms.
- Lower your body by bending your elbows until your shoulders are below your elbows.
- Push back up to the starting position.

### 5.3. Leg Raises

- Rest your forearms on the armrests and your back against the backrest.
- Keep your legs straight or slightly bent.
- Raise your legs towards your chest, engaging your core muscles.
- Lower your legs slowly and with control.

### 5.4. Push-ups

- Utilize the lower push-up grips on the base of the power tower.
- Assume a push-up position with hands on the grips.
- Lower your chest towards the floor, keeping your body straight.
- Push back up to the starting position.



Image 6: Exercise Demonstrations. This image displays various exercises that can be performed on the power tower,

including pull-ups, dips, leg raises, and push-ups, illustrating the versatility of the equipment.



## Why Choose Sportsroyals



**10+ Countries**

Top-Selling in  
10+ Countries



**Pro Quality Control**

Professional Quality  
Control Team



**6 Million+ Users**

Trusted By  
6 Million+ Users

*Image 7: Enhanced Back Support for Leg Raises. This image shows a user performing leg raises, highlighting the elastic cushioning and spinal support provided by the backrest for comfort during abdominal exercises.*

## 6. MAINTENANCE

---

Regular maintenance ensures the longevity and safe operation of your Sportsroyals Power Tower.

- **Cleaning:** Wipe down the equipment with a damp cloth after each use to remove sweat and dirt. Avoid abrasive cleaners.
- **Inspection:** Periodically check all bolts, nuts, and connections for tightness. Tighten any loose fasteners.
- **Wear and Tear:** Inspect pads, grips, and frame for any signs of wear, cracks, or damage. Replace worn or damaged parts immediately.
- **Storage:** Store the power tower in a dry, clean environment away from direct sunlight and extreme temperatures.

## 7. TROUBLESHOOTING

---

If you encounter issues with your Sportsroyals Power Tower, refer to the following common problems and solutions.

- **Equipment is Wobbly:**

- Ensure all bolts and nuts are securely tightened.
- Check that the power tower is placed on a flat, level surface. Adjust the foot covers if the floor is uneven.

- **Difficulty during Assembly:**

- Refer to the assembly diagrams carefully. Some parts may appear similar but have specific orientations.
- Ensure you are using the correct hardware for each step. It is helpful to sort and label hardware before starting.
- Do not fully tighten bolts until all components for a section are loosely assembled, then tighten progressively.

- **Backrest Adjustment is Stiff:**

- Ensure the adjustment pin is fully disengaged before attempting to slide the backrest.
- Check for any obstructions or debris in the adjustment mechanism.

## 8. SPECIFICATIONS

---

Feature	Detail
Brand	Sportsroyals
Model Number	FB-20YTXS01
Material	Alloy Steel
Color	Black
Maximum Weight Recommendation	450 lbs
Item Weight	28 Kilograms
Product Dimensions (L x W x H)	107.44 x 81.28 x 235.46 cm
Handle Type	Fixed
Included Components	Assembly tools and instructions
UPC	788481660783

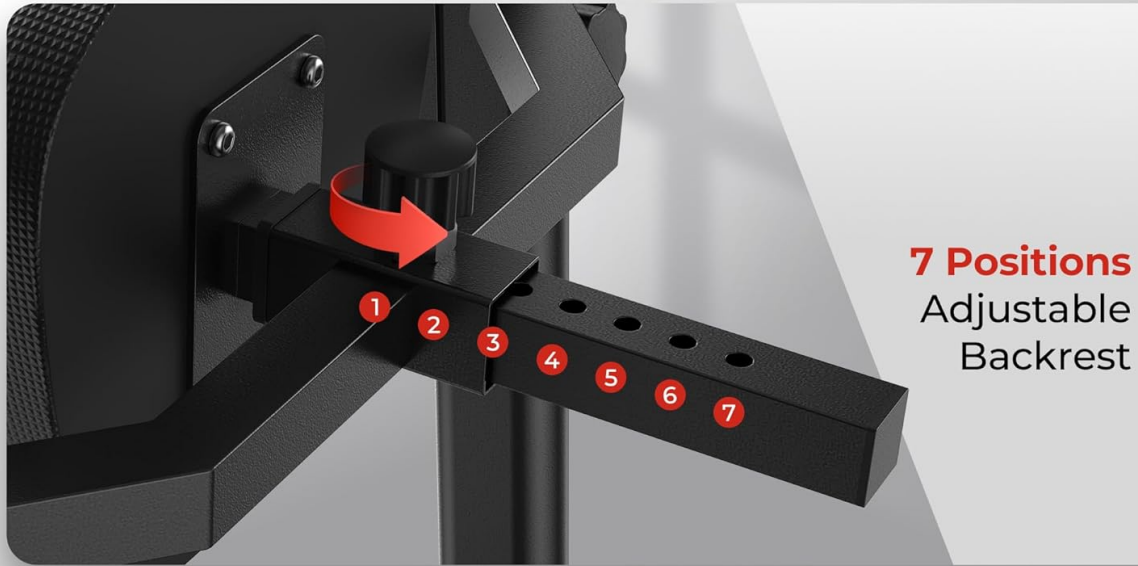

**7 Positions**  
Adjustable  
Backrest



**10°** Inclined Armrests



**3 Angle** Push-up Grips

*Image 8: Product Dimensions. This diagram provides detailed measurements of the Sportsroyals Power Tower, including its adjustable height range from 70.1 to 92.7 inches, width, and depth.*

## 9. WARRANTY AND SUPPORT

---

For warranty information, product support, or to order replacement parts, please contact Sportsroyals customer service. Refer to your purchase documentation for specific warranty terms and contact details. Typically, Sportsroyals products come with a limited warranty covering manufacturing defects. Keep your proof of purchase for warranty claims.

For assistance, visit the official Sportsroyals website or contact their support team directly.