

Manuals+

[Q & A](#) | [Deep Search](#) | [Upload](#)

manuals.plus /

› [Ariston](#) /

› [Ariston PRO1 ECO 50 L Electric Storage Water Heater User Manual](#)

Ariston PRO1 ECO 50 L

Ariston PRO1 ECO 50 L Electric Storage Water Heater User Manual

Model: PRO1 ECO 50 L (3820019)

1. IMPORTANT SAFETY INFORMATION

Please read this manual carefully before installing, operating, or performing maintenance on your Ariston PRO1 ECO 50 L Electric Storage Water Heater. Retain this manual for future reference. Failure to follow these instructions could result in property damage, personal injury, or death.

- Installation must be performed by a qualified professional in accordance with all local and national regulations.
- Ensure the electrical supply matches the specifications of the water heater.
- Do not operate the water heater if it is damaged or malfunctioning.
- The appliance is equipped with an ABS safety package providing protection for both the product and its users.
- The integrated Anti Legionella system performs a heating cycle to 65°C periodically to sanitize the water and remove bacteria.
- Always disconnect power before performing any maintenance or service.

2. PRODUCT OVERVIEW

The Ariston PRO1 ECO 50 L is an electric storage water heater designed for energy efficiency and durability. It is suitable for domestic and light commercial environments.

Key Features:

- **WaterPlus Technology:** Reduces the mixing of incoming cold water with stored hot water, providing up to 16% more hot water availability.
- **Eco Evo Function:** Learns daily usage patterns to optimize heating and save up to 14% on energy bills.
- **TitanShield Technology:** The inner tank is enamelled with titanium for anti-corrosion and rust resistance, complemented by a large magnesium anode for extended product life.
- **T-MAX Function:** Boosts the heating process to quickly meet unexpected hot water demands.
- **Unvented Kit:** Supplied with a full unvented kit including an expansion vessel, tundish, and pressure reducing valve.



Figure 1: Ariston PRO1 ECO 50 L Electric Storage Water Heater, front view.

PRO1 ECO ELECTRIC STORAGE WATER HEATER



Figure 2: Internal and external features of the PRO1 ECO water heater, including TitanShield Technology, Absolute Safety System, Modern Curved Design, Electronic Control with Indicative LEDs, High Quality Heating Elements, Premium Insulation Material, Function Buttons, and Selection Buttons.

The energy label features a blue background with a white border. On the left, there is a large Union Jack flag. To the right of the flag, the word 'ENERGY' is written in large, white, bold, sans-serif capital letters. Below the flag and the word 'ENERGY', there is a small house icon followed by the text 'ARISTON PRO1 ECO 50 V UK EU'. To the right of this text, the number '(3201491)' is displayed in a smaller font. At the bottom left, there is a black icon of a water tap with the letter 'M' below it.

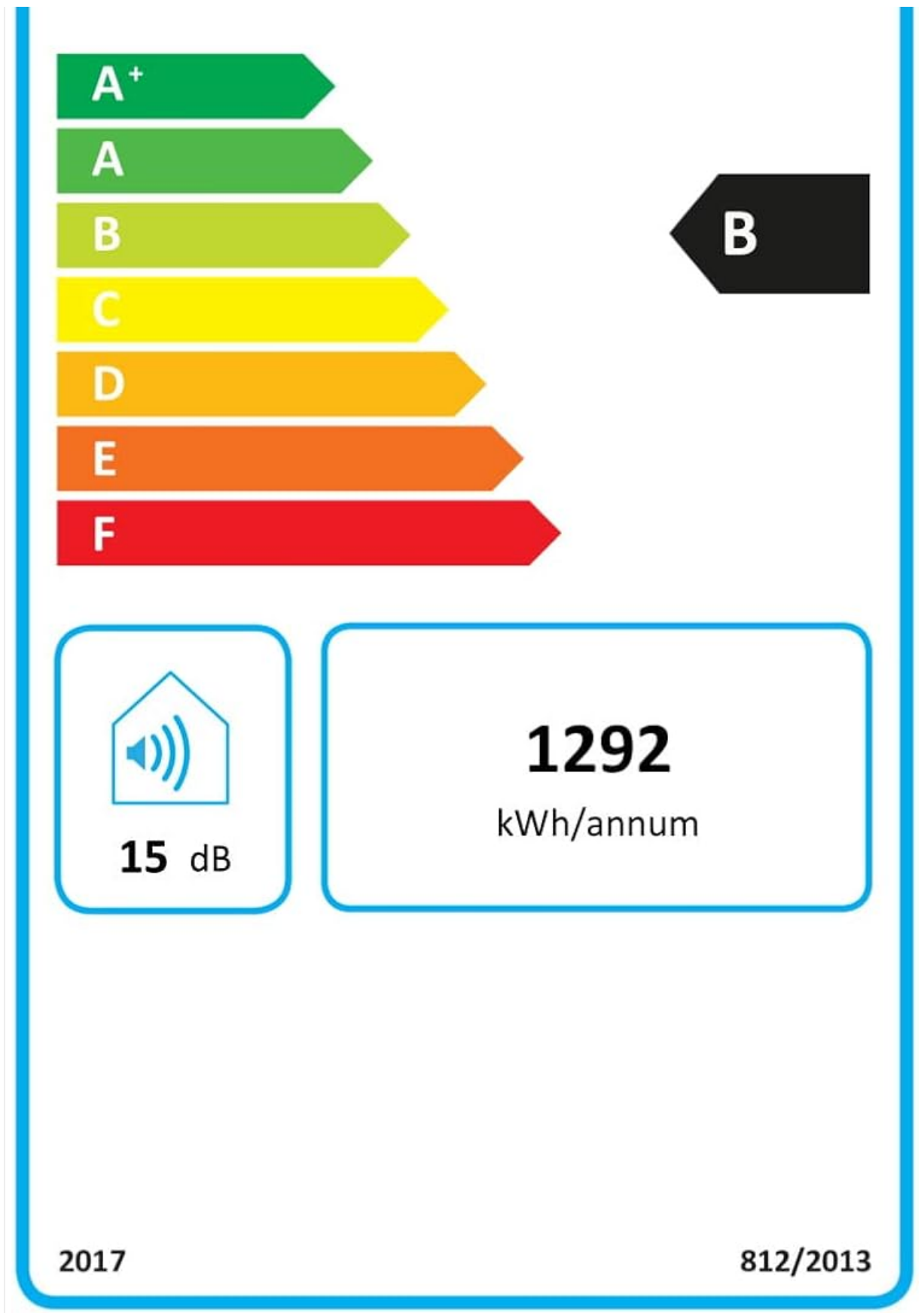

Figure 3: Energy efficiency label for the Ariston PRO1 ECO 50 L water heater, showing a B class ERP rating and annual energy consumption of 1292 kWh.

3. SETUP AND INSTALLATION

This water heater is designed and manufactured to comply with regulations for installation in the UK. Installation must be carried out by a qualified professional.

3.1 Unvented Kit Components

The PRO1 ECO 50 L is supplied with a complete unvented kit to ensure safe and compliant operation. This kit includes:

- Expansion Vessel & Non-Return Valve
- Combination Valve
- Discharge Tundish



Figure 4: Ariston PRO1 ECO 50L and 80L models shown alongside the included unvented kit components: expansion vessel & non-return valve, combination valve, and discharge tundish.

3.2 Dimensions

The PRO1 ECO 50 L has been designed with a compact width of 470mm to fit various spaces.

- Height: 605 mm
- Width: 470 mm
- Depth: 480 mm

PRO1 ECO 50

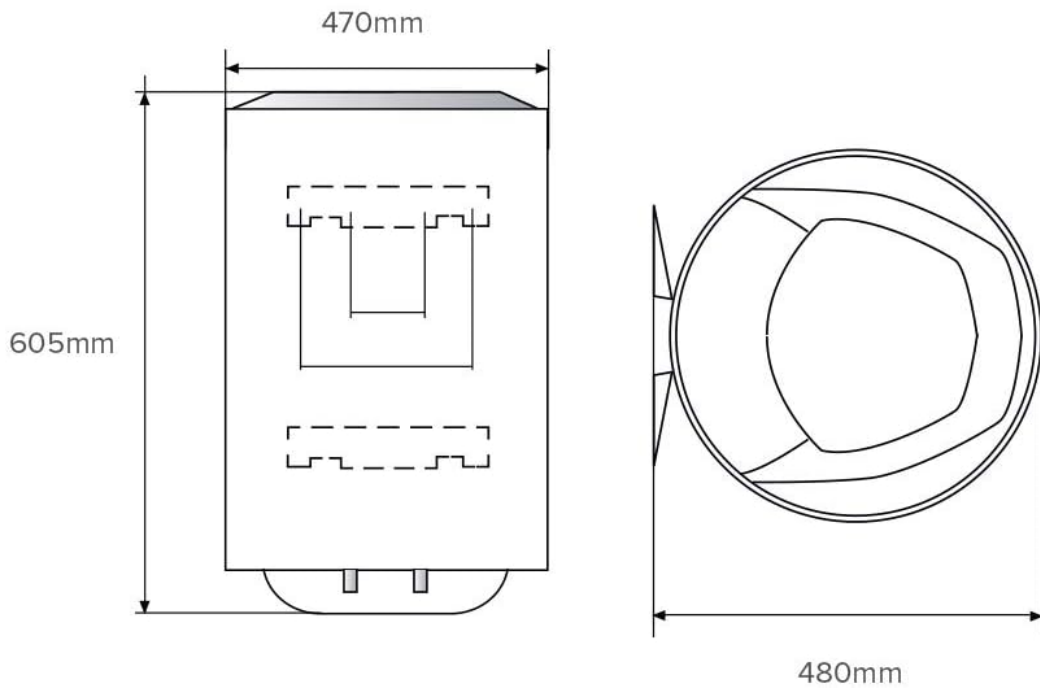

Figure 5: Technical drawing illustrating the dimensions of the Ariston PRO1 ECO 50 L water heater, showing a height of 605mm, width of 470mm, and depth of 480mm.

4. OPERATING INSTRUCTIONS

4.1 Control Panel

The water heater features a user-friendly control panel for setting temperature and activating special functions.

HI-TECH DISPLAY PANEL



ECO EVO: Learns end user hot water requirements during first week. Temperature is then adjusted automatically between 40°C and the maximum set, to supply the quantity of hot water analysed previously.

T-MAX: Boost function that raises the water temperature to 65°C when activated. Then, returns to previously set temperature automatically. This is useful when additional hot water is required.

SHOWER READY: Indicates when there is enough hot water available to have one shower.

Figure 6: Close-up of the Ariston PRO1 ECO Hi-Tech Display Panel, highlighting the ECO EVO, T-MAX, and SHOWER READY indicators and controls.

- **ECO EVO Function:** This intelligent function learns your hot water requirements during the first week of use. It then automatically adjusts the temperature between 40°C and the maximum set temperature to efficiently supply the required hot water, optimizing energy consumption.
- **T-MAX Function:** Activate this boost function to rapidly raise the water temperature to 65°C. After reaching the desired temperature, it returns to the previously set temperature. This is useful for situations requiring a quick increase in hot water availability.
- **SHOWER READY Indicator:** This indicator illuminates when there is sufficient hot water available for a shower.

4.2 Temperature Adjustment

Use the '+' and '-' buttons on the control panel to adjust the desired water temperature. The display will show the current setting.

5. MAINTENANCE

Regular maintenance ensures the longevity and efficient operation of your water heater. Always disconnect the power supply before performing any maintenance.

- **Anode Inspection:** The TitanShield technology includes a magnesium anode that protects the tank from corrosion. This anode should be inspected and replaced periodically by a qualified technician, typically every 1-2 years, depending on water quality.
- **Anti Legionella Cycle:** The water heater automatically performs an Anti Legionella cycle by heating the water to 65°C to sanitize the tank. Ensure the unit remains powered for this function to operate.
- **Pressure Relief Valve:** Periodically check the pressure relief valve for proper operation. Consult a qualified professional for this inspection.
- **Cleaning:** Clean the exterior of the water heater with a soft, damp cloth. Do not use abrasive cleaners or solvents.

6. TROUBLESHOOTING

If you experience issues with your water heater, refer to the following common problems and solutions. For complex issues, contact a qualified technician.

- **No Hot Water:** Check the power supply to the unit. Ensure the circuit breaker has not tripped. Verify the temperature setting on the control panel.
- **Insufficient Hot Water:** The Eco Evo function may be learning your usage patterns. Allow time for it to adapt. Consider activating the T-MAX function for a temporary boost. Ensure the water heater capacity meets your household's demand.
- **Water Leaks:** Immediately turn off the water supply and power to the unit. Contact a qualified professional for inspection and repair.
- **Unusual Noises:** Minor noises during heating are normal. Persistent or loud noises may indicate sediment buildup or other issues. Contact a technician.

7. SPECIFICATIONS

Technical data for the Ariston PRO1 ECO 50 L Electric Storage Water Heater.



Figure 7: Detailed technical data sheet for Ariston PRO1 ECO electric storage water heaters, including specifications for 50L, 80L, and 100L models.

Ariston PRO1 ECO 50 L Technical Data

Parameter	Value (50 L Model)
Model	PRO1 ECO 50 V UK EU
Capacity	50 Liters
Power / Wattage	2000 W
Voltage	230-240 V
Max Working Temperature	80 °C
Max Working Pressure	8 bar
Heat Dispersion at 65°C	0.92 kWh/24h
IP Protection	IPX3
ERP Class	B
Weight Empty	17 kg
Weight Full	67 kg
Dimensions (H x W x D)	605 x 470 x 480 mm
Material	Titanium finished steel

Parameter	Value (50 L Model)
Energy Efficiency Class	A to G
Special Features	Eco Evo Function, WaterPlus Technology, TitanShield Technology, Anti Legionella System

8. WARRANTY AND SUPPORT

8.1 Warranty Information

The Ariston PRO1 ECO 50 L Electric Storage Water Heater typically comes with a 5-year warranty. Please refer to your purchase documentation or the official Ariston website for specific warranty terms and conditions applicable to your region.

The image displays two Ariston PRO1 ECO electric storage water heaters, one labeled '50L' and the other '80L'. Both units are white with a black base and feature the Ariston logo. To the left of the 50L unit is a red circular badge with a white house icon containing the number '5' and the text '5 YEAR WARRANTY AVAILABLE' around the perimeter. Below the heaters, the text 'INCL. UNVENTED KIT' is centered. Underneath this text, three components are shown: an expansion vessel & non-return valve, a combination valve, and a discharge tundish. Each component is accompanied by a red plus sign indicating it is included in the kit.

Figure 8: Image indicating a 5-year warranty available for Ariston PRO1 ECO water heaters.

8.2 Customer Support

For technical assistance, spare parts, or warranty claims, please contact Ariston customer support.

- **Official Website:** www.aristonthermo.com or www.ariston.com
- **Product Database Email:** info.product.db@ariston.com
- **Telephone:** +39073260011
- **EPREL Product Information:** <https://eprel.ec.europa.eu/qr/798936>