

Maclean MC-884

Maclean MC-884 Dual Monitor Desk Mount Instruction Manual

INTRODUCTION

Thank you for choosing the Maclean MC-884 Dual Monitor Desk Mount. This manual provides comprehensive instructions for the safe and efficient installation, operation, and maintenance of your new monitor mount. This desk mount is designed to support up to two LED, LCD, QLED, or OLED screens with diagonal sizes ranging from 17 to 32 inches, and a maximum load capacity of 8 kg per arm. It features full motion capabilities, including height adjustment, swiveling, tilting, and rotating, to achieve an optimal viewing angle. The mount is compatible with VESA sizes of 75 x 75 mm and 100 x 100 mm and includes an integrated cable management system for a tidy workspace.

Please read this manual thoroughly before beginning installation and retain it for future reference.

SAFETY INFORMATION

- **Weight Capacity:** Do not exceed the maximum weight capacity of 8 kg (17.6 lbs) per arm. Overloading can result in serious injury or product damage.
- **Screen Size:** Ensure your monitors are within the recommended screen size range of 17-32 inches.
- **VESA Compatibility:** Verify that your monitors have VESA mounting patterns of 75x75mm or 100x100mm.
- **Desk Thickness:** Confirm your desk thickness is compatible with the clamp mechanism (minimum 10mm, maximum 88mm).
- **Assembly:** Assemble the product exactly as described in this manual. Incorrect assembly may cause damage or injury.
- **Tools:** Use appropriate tools for assembly.
- **Children:** Keep small parts away from children.
- **Maintenance:** Regularly check all screws and connections to ensure they remain secure.

PACKAGE CONTENTS

Please check that all components are present and undamaged before proceeding with installation. If any parts are missing or damaged, contact your retailer for assistance.

- Main Pole with Desk Clamp
- Dual Monitor Arm Assembly
- VESA Mounting Plates (x2)
- Cable Management Clips
- Hardware Kit (screws, washers, Allen keys)



Image: All components of the Maclean MC-884 dual monitor desk mount laid out, including the main pole, dual arms, VESA plates, and hardware.

SPECIFICATIONS

Feature	Specification
---------	---------------

Feature	Specification
Manufacturer	Maclean
Model Number	MC-884
Mounting Type	Table Clamp
Movement Type	Articulating (Full Motion)
Material	Alloy Steel, Aluminum
Color	Black
Compatible Screen Size	17-32 inches
VESA Compatibility	75x75mm, 100x100mm
Load Capacity	Up to 8 kg (17.6 lbs) per arm
Desk Thickness Compatibility	10mm - 88mm
Item Weight	3.72 Kilograms

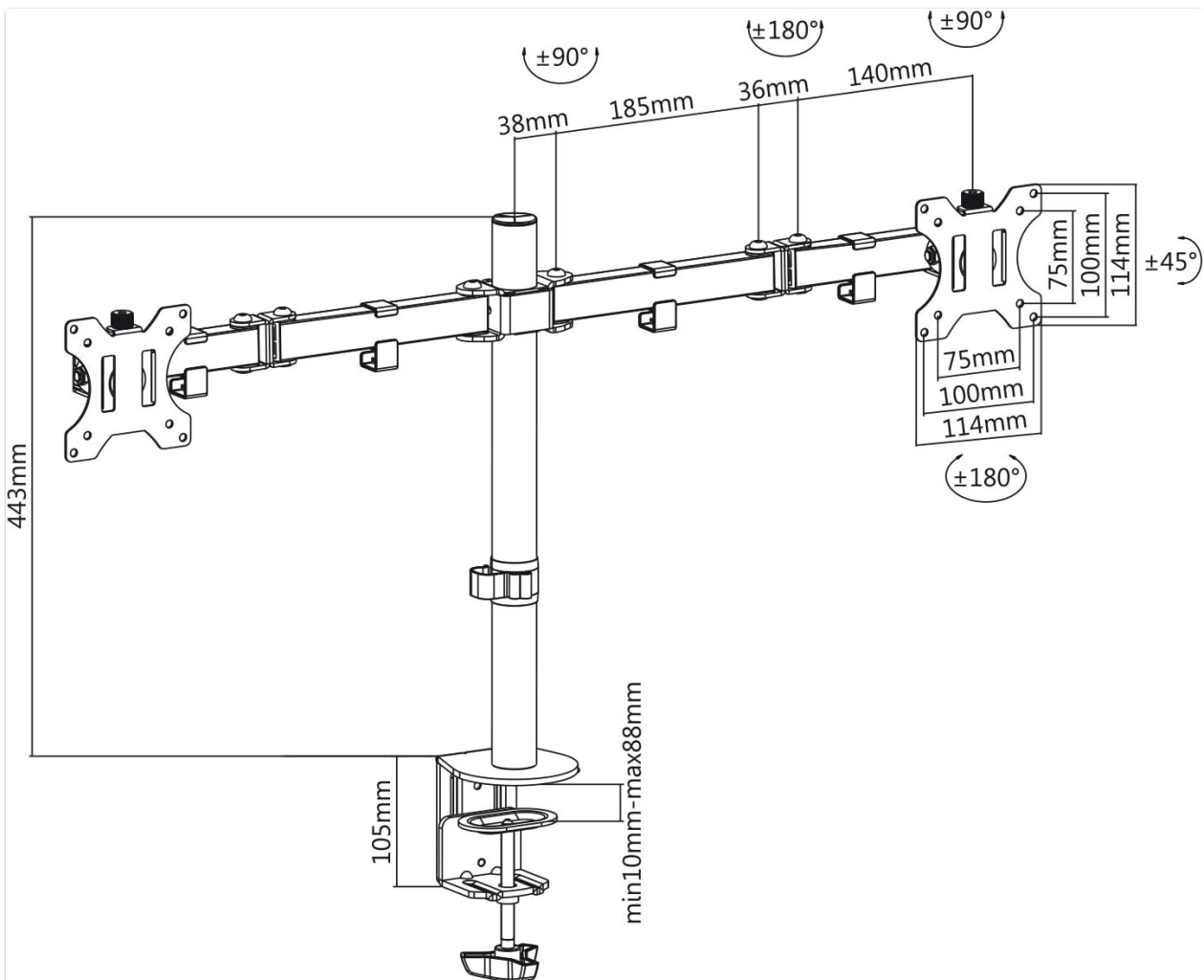

Image: Technical drawing illustrating the dimensions and articulation capabilities of the monitor mount, including VESA patterns.

SETUP AND INSTALLATION

Follow these steps carefully to install your Maclean MC-884 Dual Monitor Desk Mount.

Step 1: Attach the Desk Clamp

1. Place the main pole assembly onto your desk.
2. Adjust the desk clamp to fit your desk thickness (10mm to 88mm).
3. Tighten the clamp screw securely until the mount is stable on the desk. Ensure it is firm but do not overtighten.



Image: A detailed view of the desk clamp mechanism, showing how it secures the main pole to the desk surface.

Step 2: Attach VESA Plates to Monitors

1. Carefully place your monitor face down on a soft, clean surface to prevent scratches.
2. Align a VESA mounting plate with the VESA holes on the back of your monitor (75x75mm or 100x100mm).
3. Secure the VESA plate to the monitor using the appropriate screws from the hardware kit. Do not overtighten. Repeat for the second monitor.



Image: A close-up showing the VESA plate and its connection point to the monitor arm, ready for monitor attachment.

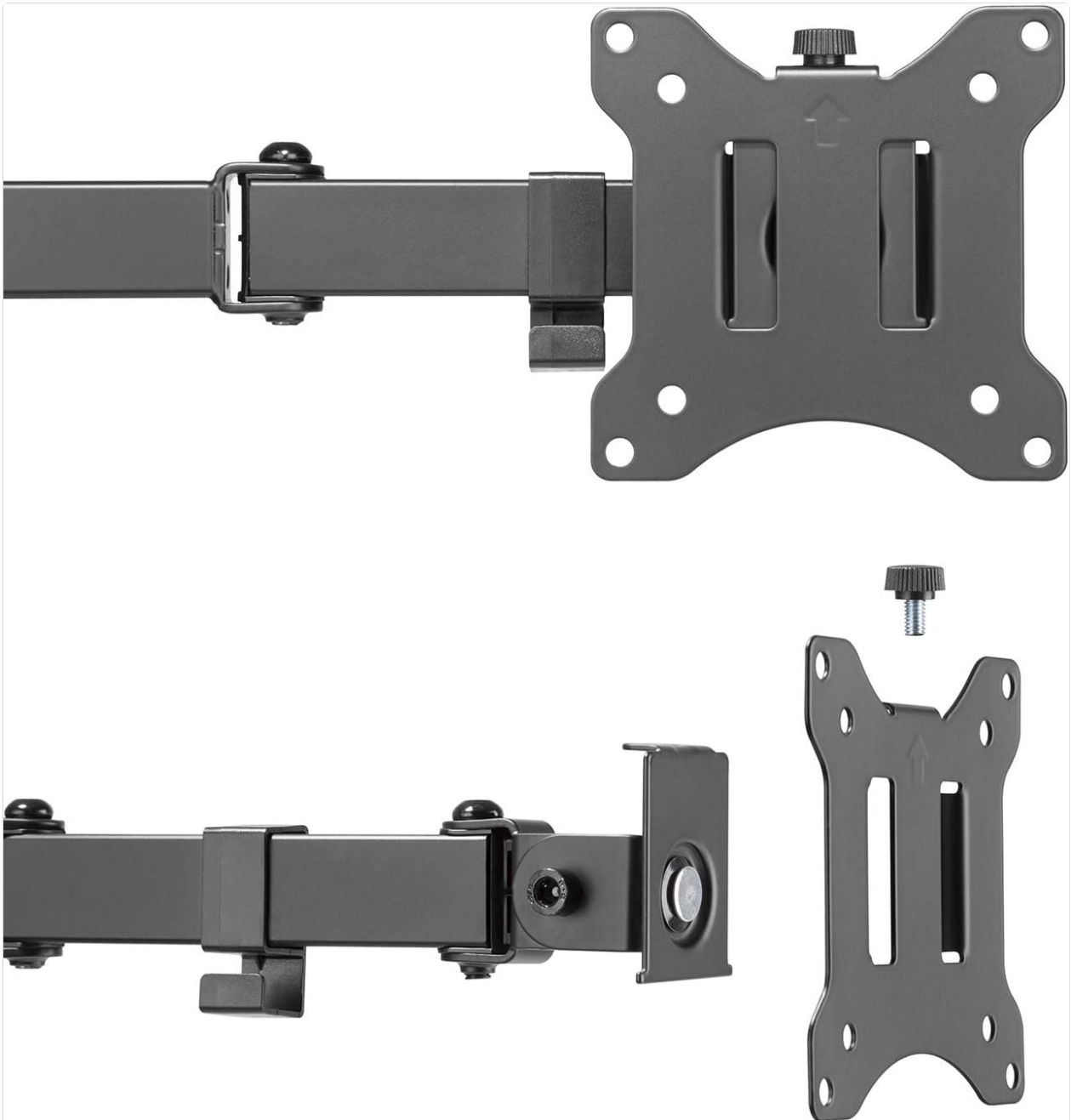

Image: A VESA plate shown with a screw, illustrating the method of attachment to the back of a monitor.

Step 3: Mount Monitors to Arms

1. With assistance, carefully lift each monitor and slide the VESA plate attached to the monitor onto the corresponding arm bracket.
2. Ensure the monitor is securely seated on the arm bracket. Tighten any safety screws or clips if provided.



Image: A view from behind the dual monitor setup, showing two monitors securely attached to the arms and initial cable routing.

Step 4: Cable Management

1. Route your monitor cables (power, video, etc.) through the integrated cable management clips along the arms and down the main pole.
2. Close the clips to hold the cables neatly in place, reducing clutter and preventing damage.

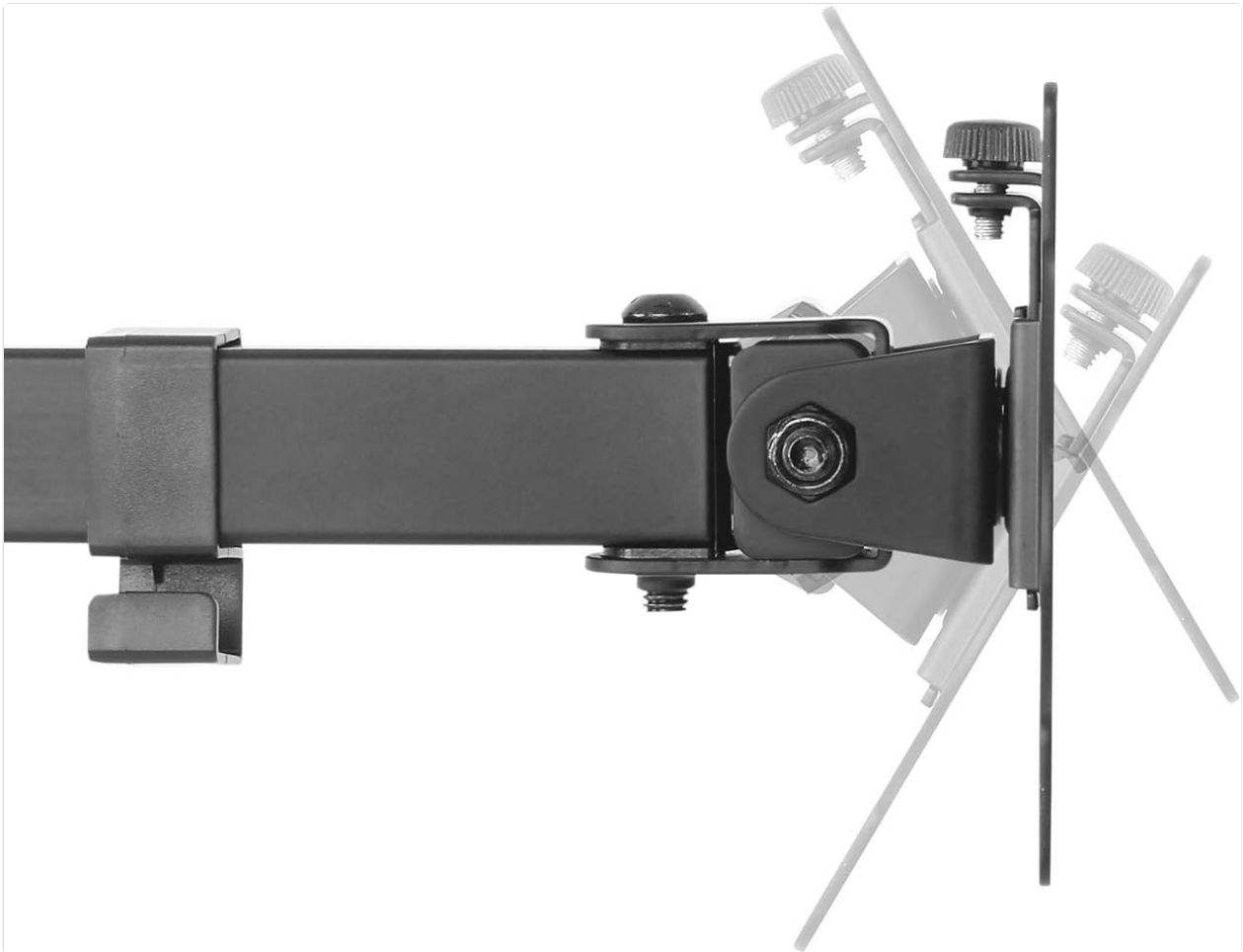

Image: A close-up of the cable management clips integrated into the monitor arm, designed to keep cables organized.

OPERATING INSTRUCTIONS

Adjusting Monitor Position

The Maclean MC-884 offers full motion adjustability for optimal viewing comfort.

- **Height Adjustment:** Loosen the collar on the main pole to slide the entire arm assembly up or down. Retighten the collar once the desired height is reached.
- **Tilt Adjustment:** The monitor can be tilted up or down to reduce glare and improve viewing angles. Loosen the tilt knob behind the VESA plate, adjust the angle, and then retighten.



Image: A close-up view of the monitor tilt mechanism, showing the range of vertical adjustment.

- **Swivel Adjustment:** Each arm can swivel horizontally up to 180 degrees at two pivot points, and the entire arm assembly can pivot 360 degrees around the main pole. This allows for flexible screen positioning.
- **Rotation Adjustment:** The VESA plate allows for 360-degree rotation, enabling you to switch your monitor between landscape and portrait orientations.

Always support your monitor when making adjustments to prevent accidental drops or damage.

MAINTENANCE

To ensure the longevity and proper function of your Maclean MC-884 Dual Monitor Desk Mount, follow these simple maintenance guidelines:

- **Cleaning:** Wipe the mount with a soft, damp cloth. Avoid using abrasive cleaners or solvents, as they may damage the finish.
- **Inspection:** Periodically check all screws, bolts, and connections to ensure they are tight and secure. Loose connections can lead to instability.
- **Lubrication:** No lubrication is typically required for the moving parts. If any joints become stiff, consult customer support.

TROUBLESHOOTING

If you encounter any issues with your monitor mount, refer to the following common problems and solutions:

- **Mount is unstable:** Ensure the desk clamp is tightened securely to the desk. Check that the desk surface is stable and can support the weight of the mount and monitors.
- **Monitors are not level:** Adjust the tilt and rotation mechanisms on each VESA plate to align the

monitors. Ensure the main pole is vertically straight.

- **Difficulty adjusting monitor position:** Check if any adjustment knobs or screws are overtightened. Loosen them slightly to allow movement, then retighten to hold the position.
- **Cables are messy:** Re-route cables through the integrated cable management clips, ensuring they are properly secured.

If the problem persists, please contact Maclean customer support for further assistance.

WARRANTY AND SUPPORT

For warranty information and customer support, please refer to the documentation provided with your purchase or visit the official Maclean website. Keep your proof of purchase for any warranty claims.