

[Manuals.plus](#) /

› [tectake](#) /

› tectake Fitness Multi-Gym (Model 402756-NL) User Manual

tectake 402756-NL

tectake Fitness Multi-Gym (Model 402756-NL) User Manual

Comprehensive instructions for assembly, operation, and maintenance.

INTRODUCTION

The tectake Fitness Multi-Gym is engineered to deliver a complete strength training experience within your home environment. This versatile equipment supports a wide array of exercises, effectively targeting various muscle groups. Its design accommodates all fitness levels, from beginners to advanced users, helping you achieve your personal fitness objectives. Key features include adjustable weight resistance, a robust steel frame, and durable plastic-coated steel cables, all contributing to maximum safety and stability during workouts. Its compact footprint also makes it an ideal solution for smaller living spaces or home gyms.

SETUP AND ASSEMBLY

The tectake Fitness Multi-Gym requires assembly prior to use. For detailed, step-by-step instructions, please refer to the dedicated assembly guide included with your product packaging. It is crucial to ensure all components are present and undamaged before commencing assembly.

- **Preparation:** Unpack all parts and verify against the parts list in the assembly guide.
- **Location:** Choose a flat, stable, and spacious area for assembly and use. A protective mat is recommended to safeguard your flooring and minimize noise.
- **Tools:** Gather all necessary tools as specified in the assembly guide.
- **Safety:** Always follow the safety instructions provided in the assembly guide. It is advisable to have a second person assist with assembly.

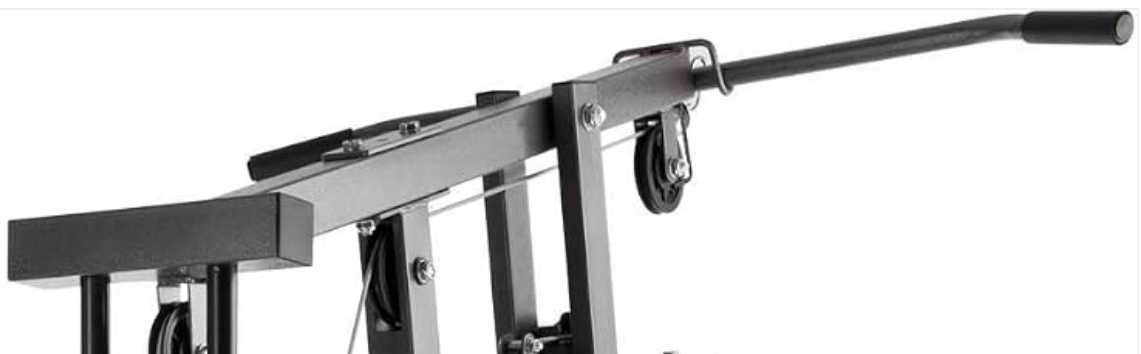



Figure 1: Front view of the assembled tectake Fitness Multi-Gym. This image shows the complete structure including the weight stack and various exercise stations.



Figure 2: Side view of the tectake Fitness Multi-Gym. This perspective highlights the depth and arrangement of the different exercise components.

OPERATING INSTRUCTIONS

The tectake Fitness Multi-Gym offers a diverse range of exercises to effectively train your torso, arms, and legs. Always perform exercises with controlled movements and proper form to prevent injury.

- **Weight Adjustment:** To adjust the resistance, simply insert the selector pin into the desired weight plate

within the stack. Always start with a lighter weight to become familiar with the exercise movement before increasing resistance.

- **Upper Pulley System:** This station is ideal for exercises such as lat pulldowns, triceps pushdowns, and abdominal crunches. Ensure a firm and secure grip on the attachment and execute movements smoothly.
- **Butterfly / Chest Press:** Utilize the padded arms for both chest press and butterfly (pec deck) exercises. Adjust the seat height to ensure proper alignment of your shoulders and chest with the pivot points.
- **Lower Pulley System:** This versatile station is suitable for seated rows, bicep curls, and various leg exercises when an ankle strap (if included) is attached. Maintain a stable posture throughout the exercise.
- **Leg Developer:** Perform leg extensions and leg curls using the padded leg developer. Proper alignment of your knees with the machine's pivot point is essential for effective and safe training.



Figure 3: User performing a chest press exercise. This demonstrates the proper form for engaging chest muscles using the multi-gym's press station.



Figure 4: User performing a lat pulldown exercise. This illustrates the use of the upper pulley system for back muscle development.



Figure 5: Close-up of exercise handles. This image highlights the ergonomic design of the handles for comfortable and secure grip during workouts.

MAINTENANCE

Regular maintenance is essential to ensure the longevity, optimal performance, and safe operation of your tectake Fitness Multi-Gym.

- **Cleaning:** After each use, wipe down the frame, seat, backrest, and all padded surfaces with a damp cloth to remove sweat and dust. Avoid abrasive cleaners.
- **Lubrication:** Periodically inspect all moving parts, especially cables and pulleys, for smooth operation. Apply a silicone-based lubricant to pivot points and cable pathways if any friction or stiffness is detected.
- **Inspection:** Regularly check all nuts, bolts, and connections for tightness. Over time, vibrations from use can loosen fasteners. Inspect cables for any signs of fraying, wear, or damage. Examine pulleys for cracks or excessive wear. Replace any worn or damaged parts immediately to prevent accidents.
- **Storage:** Store the multi-gym in a dry, temperate environment, away from direct sunlight, excessive humidity, or extreme temperature fluctuations, which can degrade materials.

TROUBLESHOOTING

If you encounter any issues with your tectake Fitness Multi-Gym, consult the following common troubleshooting tips:

- **Squeaking Noises:** If you hear squeaking during operation, first identify the source. Check all moving parts, especially pulleys, cable guides, and pivot points. Apply a silicone-based lubricant to the affected areas. Ensure all bolts and connections are securely tightened.
- **Cable Snagging or Rough Movement:** Inspect the entire cable path for any obstructions or debris. Ensure all pulleys are clean and rotate freely. Check the cables themselves for any signs of fraying or damage. If a cable is damaged, it must be replaced immediately.
- **Unstable Frame:** If the multi-gym feels unstable, verify that it is placed on a completely level surface. Retighten all frame bolts and nuts. Ensure that all rubber feet caps or stabilizers are properly installed and making full contact with the floor.
- **Weight Plates Sticking:** Ensure the guide rods for the weight stack are clean and free of debris. A light application of silicone lubricant on the guide rods can help. Check that the selector pin is fully inserted and not bent.

SPECIFICATIONS

Below are the key technical specifications for the tectake Fitness Multi-Gym (Model 402756-NL):

Feature	Value
Brand	tectake
Model Number	402756-NL
Overall Dimensions (L x W x H)	Approx. 160 x 101 x 203 cm (63 x 40 x 80 inches)
Product Dimensions (L x W x H)	203P x 101l x 203H centimeters
Maximum Load Capacity	150 kg (330 lbs)
Weight Stack	8 x 4.5 kg & 1 x 3.5 kg (Total 39.5 kg / 87 lbs)
Frame Material	Steel (approx. 5 x 5 cm / 2 x 2 inches)
Cable Type	Plastic-coated steel cables
Upholstery Thickness	Approx. 4 cm (1.6 inches)
Color	Grey (schwarz.)

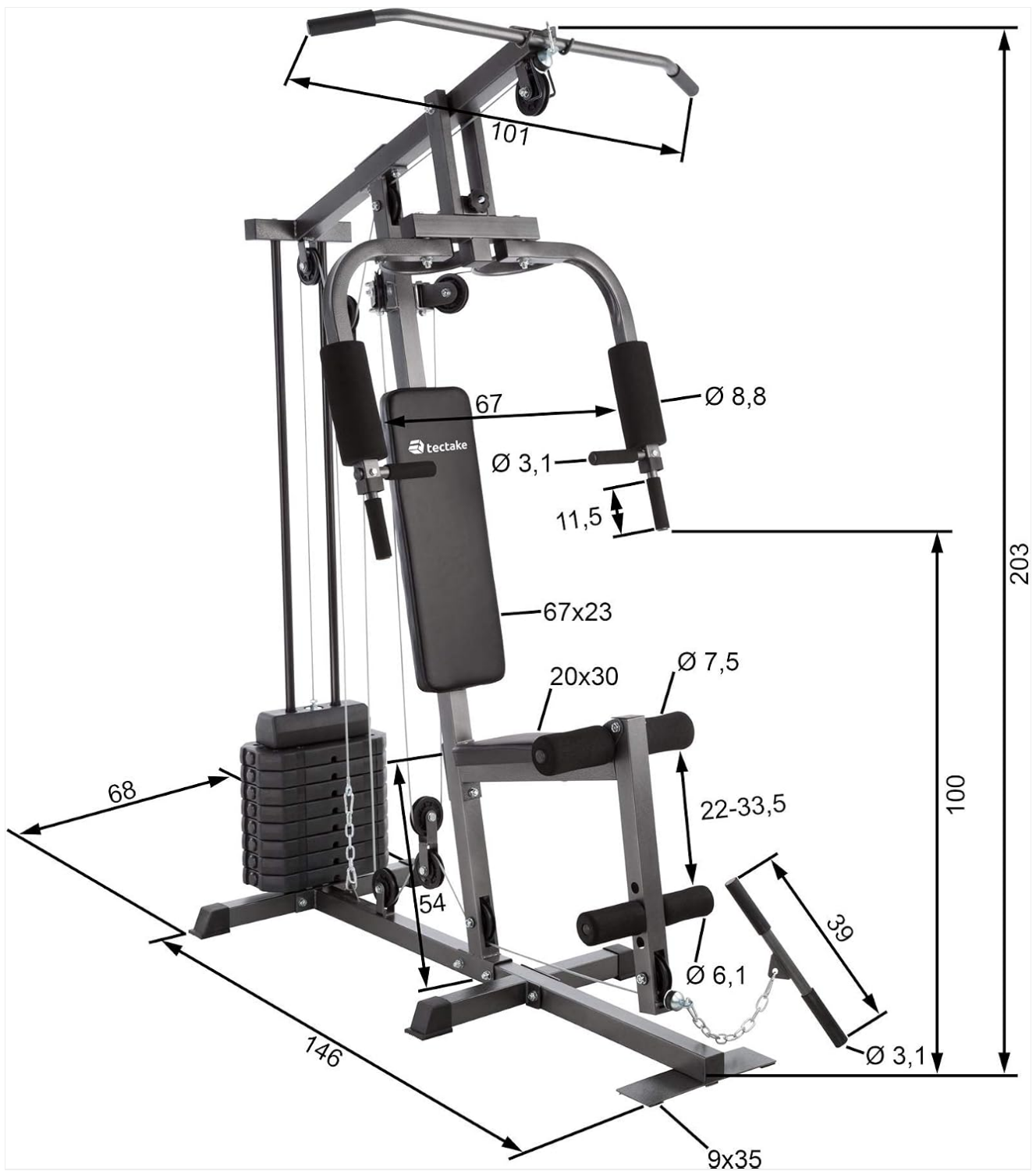

Figure 6: Dimensional diagram of the multi-gym. This illustration provides precise measurements for planning your space.





Figure 7: Close-up of the weight stack. This shows the individual weight plates and the selector pin mechanism.



Figure 8: Detail of the pulley system. This image highlights the robust construction of the pulleys and cable connections.

WARRANTY INFORMATION

This tectake Fitness Multi-Gym is covered by a standard manufacturer's warranty. For complete details regarding the terms, conditions, and duration of your warranty, please refer to the warranty card included in your product packaging. You may also visit the official tectake website for the most up-to-date warranty information and registration procedures.

CUSTOMER SUPPORT

Should you require technical assistance, need to order spare parts, or have any further inquiries regarding your tectake Fitness Multi-Gym, please do not hesitate to contact tectake customer support. Contact information, including phone numbers and email addresses, can typically be found on the tectake website or within the product documentation provided with your purchase.