

hntoolight WS2815

hntoolight WS2815 DC12V RGB LED Strip Light User Manual

Model: WS2815

1. INTRODUCTION

Thank you for choosing the hntoolight WS2815 DC12V RGB LED Strip Light. This individually addressable LED strip features a dual-signal design, ensuring continuous operation even if one LED fails. It operates on 12V DC, offers vibrant RGB lighting, and is suitable for various indoor lighting applications. This manual provides essential information for safe installation, operation, and maintenance of your LED strip light.



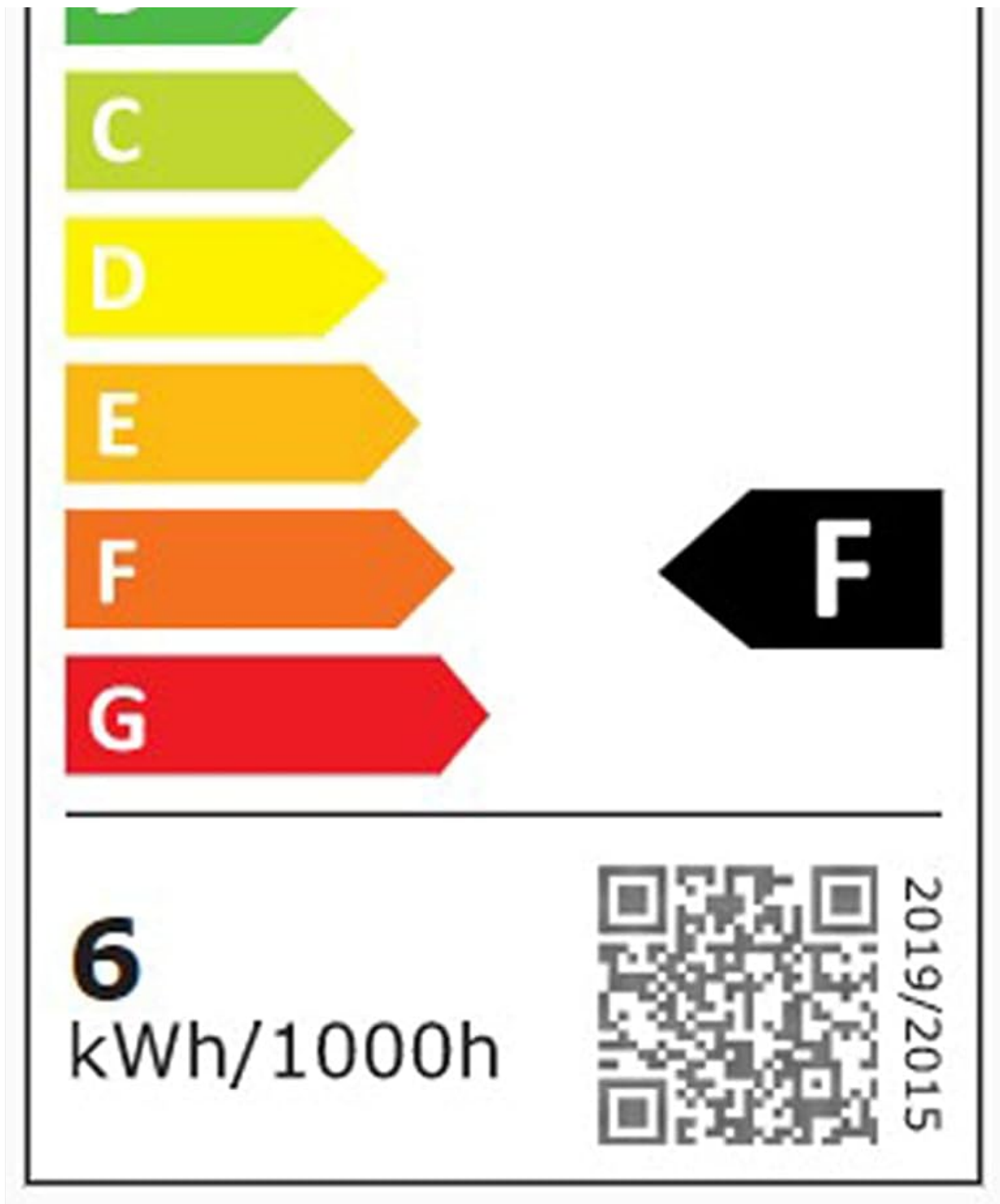

Image 1.1: Overview of the hntoolight WS2815 LED Strip Light, showing its flexible design and individual LED segments.

2. SAFETY INFORMATION

- Ensure the power supply is disconnected before installation or maintenance.
- Only use a DC12V power supply. Using an incorrect voltage will damage the product.
- Do not bend the LED strip sharply, as this may damage the circuit board or LEDs.
- This product is rated IP30, meaning it is not waterproof. Avoid exposure to water or high humidity.
- Keep out of reach of children.
- Do not stare directly into the illuminated LEDs for extended periods.

3. PACKAGE CONTENTS

- 1 x hntoolight WS2815 DC12V RGB LED Strip Light (5 meters, 60 LEDs/meter)

4. SETUP AND INSTALLATION

4.1 Understanding the WS2815 LED Strip

The WS2815 LED strip features individually addressable LEDs with a dual-signal design. Each LED has an integrated control IC (WS2815 IC) and is connected with copper brackets and pure gold wires for reliable performance.

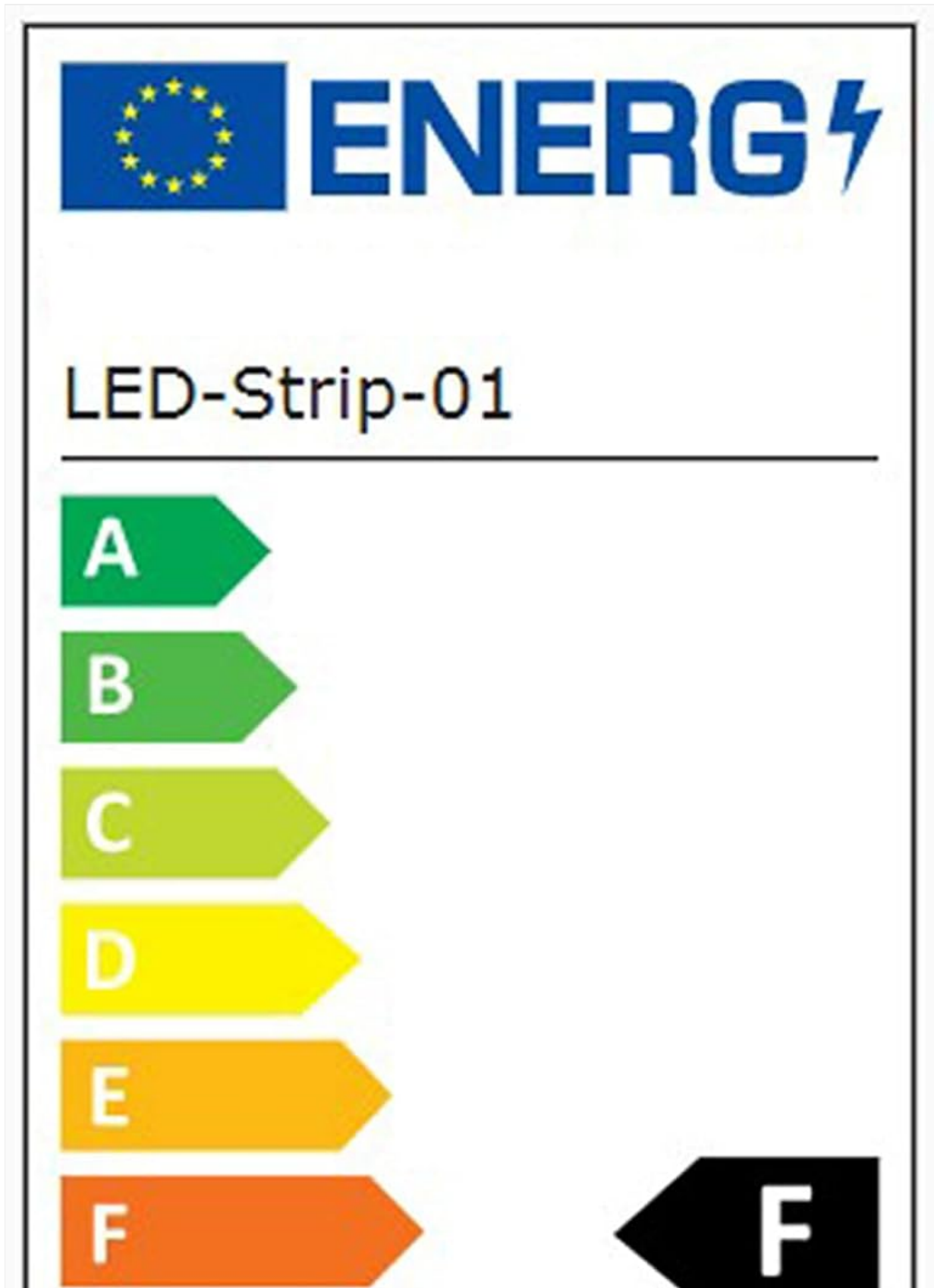



Image 4.1: Diagram illustrating the internal structure of a WS2815 LED, highlighting the dual data lines, IC, copper bracket, and pure gold wires.

4.2 Connecting the LED Strip

The LED strip comes with 4-pin connectors for power and data input/output. Ensure correct polarity and data direction when connecting to a controller and power supply.



SPECIFICATION

WS2815 LED STRIP

Signal Break-Point Continuous Transmission

If one LED is defective, the following LEDs can still work.



WS2815 LED Strip

Image 4.2: Illustration of the 4-pin connectors on the LED strip, showing male and female ends for data input/output and voltage-adding wires.

4.3 End-to-End Connection and Voltage Adding

For longer installations or when connecting multiple strips end-to-end, it is recommended to add voltage every 16.4 feet (5 meters) or every 300 LEDs. This prevents voltage drop and ensures consistent brightness along the entire length of the strip.

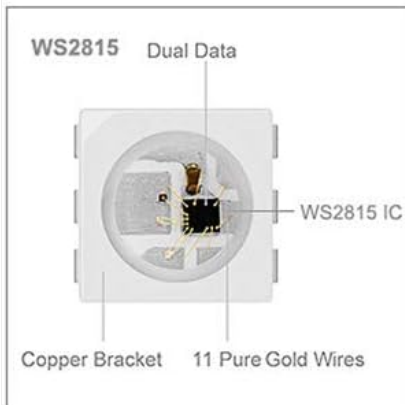

Image 4.3: Diagram showing how to connect LED strips end-to-end and where to add additional voltage for longer runs to maintain brightness.

4.4 Cutting the LED Strip

The WS2815 LED strip is cuttable. You can cut the strip at designated marks, typically every LED segment, without affecting the functionality of the remaining sections. Always cut along the marked lines to avoid damaging the circuit.

FEATURES



Individually Addressable
Every LED is Addressable. One IC Controls One LED



Cuttable
You Can Cut Every LED, The Rest Of Them Can Work Fine

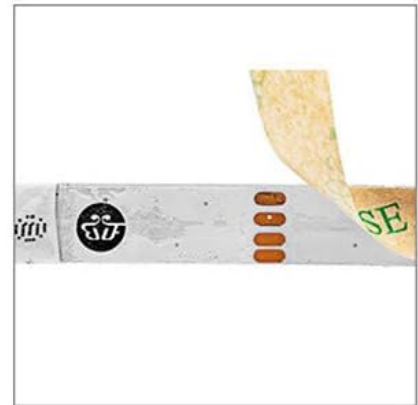

3M Adhesive
There is 3M Tape On The PCB's Back. (Only IP30 And IP65) Note: IP67 Gets No 3M Tape.

WS2815

IP30



IP65



IP67

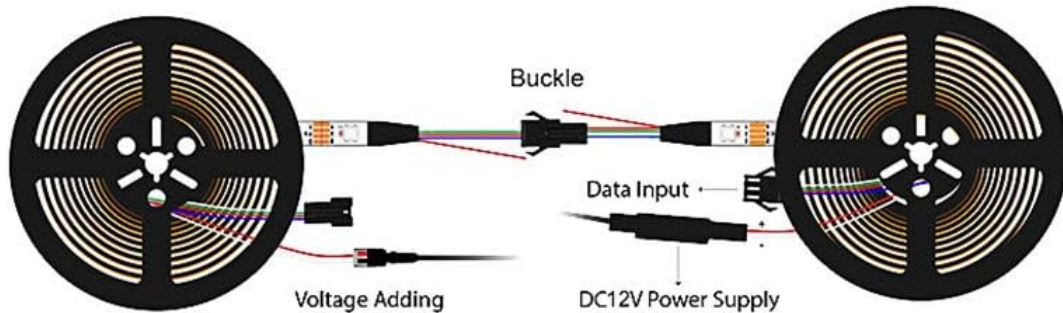
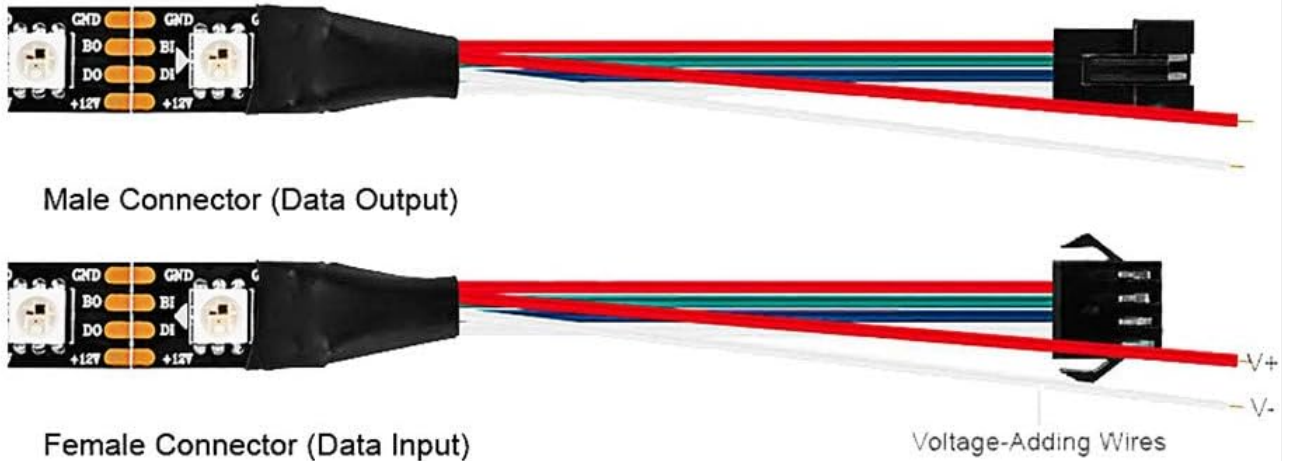

Image 4.4: Illustration demonstrating where to safely cut the LED strip using scissors, indicating that the rest of the strip will continue to function.

4.5 Mounting the LED Strip

The IP30 version of this LED strip comes with 3M adhesive tape on its back for easy mounting. For IP67 versions, 3M tape is not included, and alternative mounting methods should be used.

Ends of the LED Strip with 4Pin Connector.



END TO END CONNECT

- End to End connect
- DC12V Voltage-Adding . It is Better to Add DC5V Voltage Every 16.4ft or 300EDs, Because the LEDs at the Far End of the Strip Might Be Dimmer.

Image 4.5: Close-up view of the 3M adhesive tape on the back of the LED strip, used for mounting.

5. OPERATING INSTRUCTIONS

The WS2815 LED strip is controlled via a compatible LED controller (not included). Connect the data input of the strip to the data output of your controller. Use the controller to select desired colors, patterns, and brightness levels. This strip supports various dynamic lighting effects due to its individually addressable LEDs.

5.1 Dual-Signal Break-Point Continuous Transmission

A key feature of the WS2815 is its dual-signal design. If one LED becomes defective, the signal can bypass it, allowing the subsequent LEDs to continue functioning normally. This enhances reliability and reduces the impact of individual LED failures.

Product Information Sheet

COMMISSION DELEGATED REGULATION (EU) 2019/2015 with regard to energy labelling of light sources

Supplier's name or trade mark: Zhongshan Duschdeluxe Tech Co., Ltd.

Supplier's address: Apex CE Specialists GmbH, Ravolzhauser str. 31a63543Neuberg, DE

Model identifier: LED-Strip-01

Type of light source:

Lighting technology used:	LED	Non-directional or directional:	NDLS
---------------------------	-----	---------------------------------	------

Light source cap-type (or other electric interface)	Direct Wire		
Mains or non-mains:	NMLS	Connected light source (CLS):	No
Colour-tuneable light source:	No	Envelope:	-
High luminance light source:	No		
Anti-glare shield:	No	Dimmable:	Only with specific dimmers
Product parameters			
Parameter	Value	Parameter	Value
General product parameters:			
Energy consumption in on-mode (kWh/1000 h), rounded up to the nearest integer	6	Energy efficiency class	F
Useful luminous flux (ϕ_{use}), indicating if it refers to the flux in a sphere (360°), in a wide cone (120°) or in a narrow cone (90°)	700 in Sphere (360°)	Correlated colour temperature, rounded to the nearest 100 K, or the range of correlated colour temperatures, rounded to the nearest 100 K, that can be set	3000...6500
On-mode power (P_{on}), expressed in W	6,0	Standby power (P_{sb}), expressed in W and rounded to the second decimal	0,00
Networked standby power (P_{net}) for CLS, expressed in W and rounded to the second decimal	-	Colour rendering index, rounded to the nearest integer, or the range of CRI-values that can be set	80
Outer dimensions without separate control gear, light-	Height	4	Spectral power distribution in the range 250 nm to 800 nm, at full-load
	Width	10	
	Depth	500	
See image in last page			

Page 1 / 3

ing control parts and non-lighting control parts, if any (millimetre)			
Claim of equivalent power ^(a)	-	If yes, equivalent power (W)	-
		Chromaticity coordinates (x and y)	0,440 0,403
Parameters for LED and OLED light sources:			
R9 colour rendering index value	1	Survival factor	0,90
the lumen maintenance factor	0,96		

(a): not applicable;

(b): not applicable;

Page 2 / 3

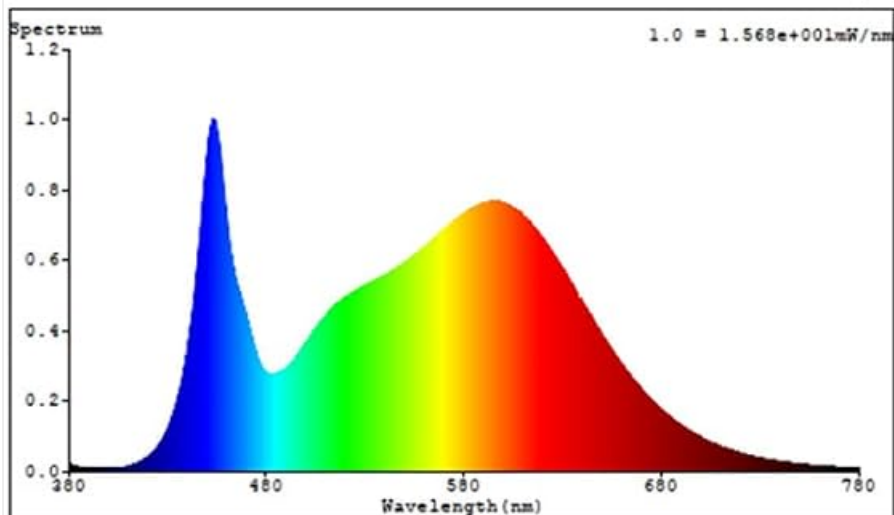

Image 5.1: Diagram illustrating the signal break-point continuous transmission feature of the WS2815 LED strip, showing how the signal bypasses a defective LED.

6. MAINTENANCE

- **Cleaning:** Gently wipe the LED strip with a dry, soft cloth. Do not use abrasive cleaners or solvents.
- **Inspection:** Periodically check connections for any loose wires or signs of damage.
- **Storage:** If storing the strip, ensure it is rolled loosely and kept in a dry, cool environment away from direct sunlight.

7. TROUBLESHOOTING

- **No Light:** Check power supply connection and ensure it is DC12V. Verify data connection to the controller.
- **Incorrect Colors/Patterns:** Ensure the controller is compatible with WS2815 LEDs and configured correctly. Check data line integrity.
- **Flickering:** May indicate insufficient power. Ensure your power supply can provide enough current for the entire strip. Consider adding voltage injection points for longer runs.
- **Partial Strip Failure:** Due to the dual-signal design, if a section fails, check the power and data connections to that specific segment. If an individual LED is defective, the rest of the strip should still function.

8. SPECIFICATIONS

LED COMPARE

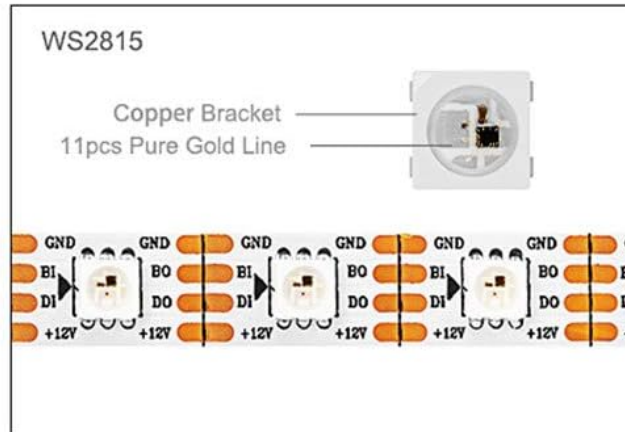

IC TYPE	WS2815
CAPACITANCE	Have
LED SIGNAL TRANSMISSION DISTANCE	3 Meter
HIGH VOLTAGE RESISTANCE	Maximum input voltage is DC12V
OPERATING TEMPERATURE	Normal combustion temperature
LED CHIP MATERIAL	Pure gold line
WARRANTY	36 Months
APPLICATION	Suitable for interior decoration such as corridor, bar , KTV. Or lighting project

Image 8.1: Detailed specifications table for the WS2815 LED strip, including IC type, capacitance, signal transmission distance, voltage resistance, operating temperature, LED chip material, warranty, and application examples.

General Product Specifications

Feature	Specification
Model	WS2815
Working Voltage	DC12V
LED Type	RGB Individually Addressable
LEDs per Meter	60 LEDs/M
Total LEDs (5m)	300 LEDs
Strip Length	5 meters (16.4 ft)
Waterproof Grade	IP30 (Non-waterproof)
PCB Color	White FPC
Power Consumption	14.4 Watts (per meter)

Feature	Specification
Control Method	Remote (via compatible controller)
Indoor/Outdoor Usage	Indoor
Special Feature	Color Changing, Dual-Signal
LED Chip Material	Pure gold line

8.1 Energy Information



Image 8.2: EU Energy Label for LED-Strip-01, indicating an energy efficiency class F and 6 kWh/1000h consumption. For more details, scan the QR code or visit <https://eprel.ec.europa.eu/qr/1287061>.



Image 8.3: Detailed Product Information Sheet providing further technical specifications and energy-related data for the LED-Strip-01.

9. WARRANTY AND SUPPORT

This hntoolight WS2815 LED Strip Light comes with a **36-month warranty** from the date of purchase. This warranty covers manufacturing defects under normal use. It does not cover damage caused by improper installation, misuse, accidents, or unauthorized modifications.

For technical support, warranty claims, or any questions regarding your product, please contact hntoolight customer service through the retailer where you purchased the product.