



[Manuals.plus](#) /

> [OOYCYOO](#) /

> OOYCYOO MPPT Solar Charge Controller 60A User Manual

OOYCYOO 60A

OOYCYOO MPPT Solar Charge Controller 60A User Manual

Model: 60A

1. INTRODUCTION AND OVERVIEW

The OOYCYOO MPPT Charge Controller 60A is an advanced solar charge regulator designed to efficiently manage power flow from your solar panels to your battery bank. Utilizing Maximum Power Point Tracking (MPPT) technology, it optimizes energy harvesting from solar panels, ensuring maximum charging efficiency. This controller is compatible with a wide range of battery types, including LiFePO₄, AGM, Sealed, Gel, and Flooded batteries, and automatically identifies 12V or 24V system voltages. Its integrated backlight LCD display provides real-time monitoring of system parameters, offering comprehensive control and diagnostic capabilities.

2. SAFETY INFORMATION

Please read all safety instructions carefully before installation and operation to prevent injury or damage to the controller and connected components.

- **Connection Order:** Always connect the battery to the charge controller FIRST. Then connect the DC load (if applicable). Finally, connect the solar panels. Disconnect in the reverse order: solar panels, then DC load, then battery.
- **Wire Gauge:** Ensure appropriate wire gauge is used for all connections, especially for battery and solar panel terminals. Undersized wires can lead to overheating and potential fire hazards. For the 60A model, 4 AWG multi-strand copper wire is recommended for battery connections to safely handle the current.
- **Polarity:** Verify correct polarity (+ to + and - to -) for all connections to prevent damage to the controller and batteries.
- **Ventilation:** Install the controller in a well-ventilated area to ensure proper heat dissipation. Avoid enclosed spaces without airflow.
- **Over-voltage Protection:** Do not exceed the maximum input power or voltage of the controller. For 12V systems, the maximum PV input power is 750W; for 24V systems, it is 1500W. The maximum open circuit voltage (Voc) for solar panels should not exceed 100V.

- **Inverter/Alternator:** Do not connect inverters, wind generators, or alternators directly to the charge controller. These devices require separate, appropriate connections.
- **Battery Voltage:** Ensure the battery voltage is sufficient (typically >9V) for the controller to recognize the system voltage.

3. PRODUCT FEATURES

- **MPPT Technology:** Advanced Maximum Power Point Tracking for optimal solar energy harvesting.
- **Wide Battery Compatibility:** Supports LiFePO4, AGM, Sealed, Gel, and Flooded lead-acid batteries.
- **Automatic System Voltage Identification:** Automatically detects 12V/24V system voltage.
- **High Charging Current:** 60A rated charging current.
- **Max PV Input Power:** Up to 750W for 12V systems and 1500W for 24V systems.
- **Comprehensive Protection:** Includes overcharge, overdischarge, overload, overheat, reverse polarity, and lightning protection functions.
- **Blacklight LCD Display:** Provides clear, real-time system data.
- **USB Output:** Two 5V 2.4A USB ports for charging external devices.
- **RS485 Communication Port:** For advanced monitoring and control (additional accessories may be required).

4. PACKAGE CONTENTS

Upon opening the package, please verify that all items are present and undamaged:

- OOYCYOO MPPT Solar Charge Controller 60A
- User Manual (this document)
- Remote Temperature Sensor
- Mounting Screws and Wall Anchors

5. SETUP AND INSTALLATION

Follow these steps for proper installation of your MPPT solar charge controller. Refer to the connection diagram for visual guidance.

CONNECTION DIAGRAM

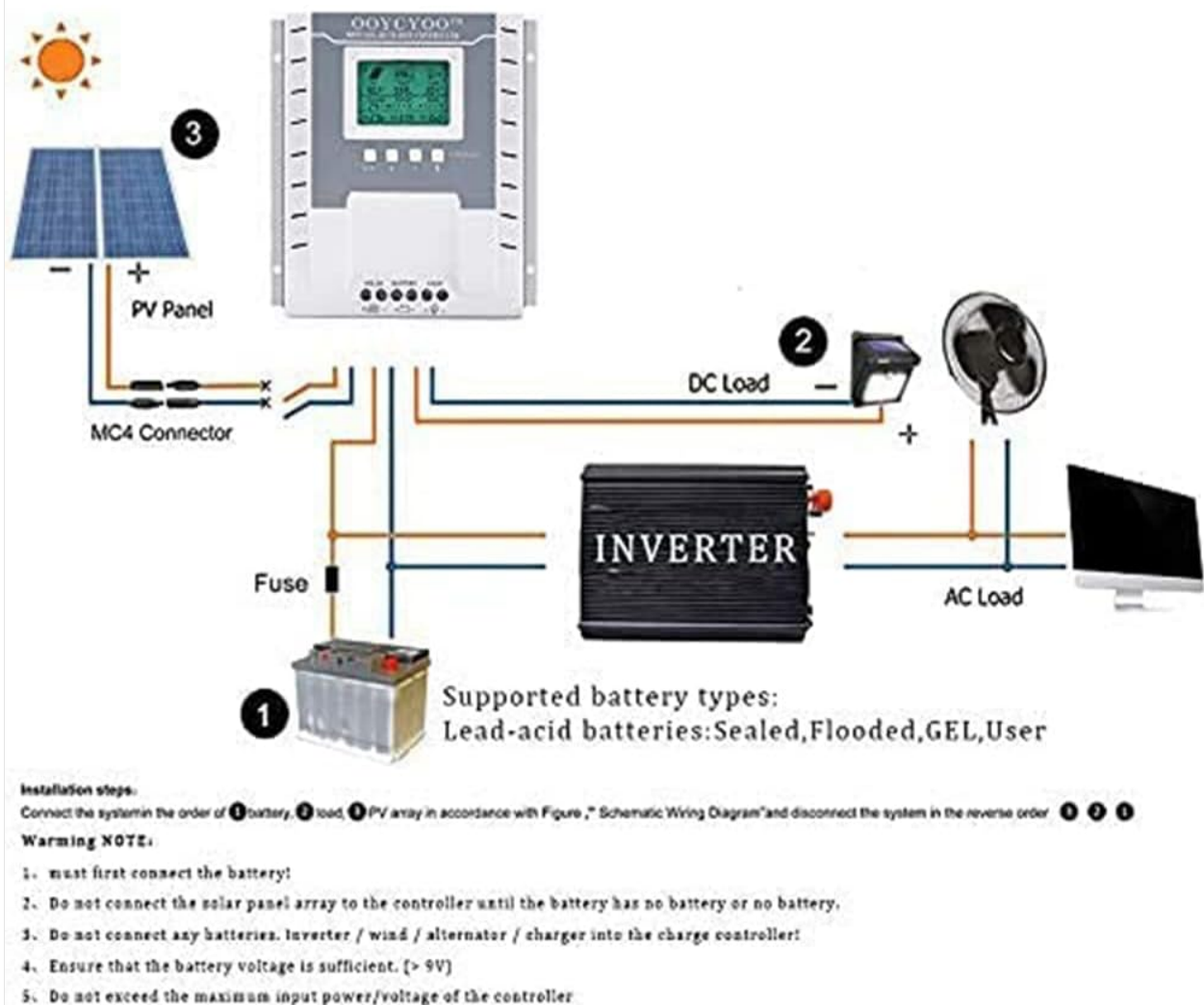

Figure 1: Connection Diagram

Installation Steps:

1. **Mounting:** Choose a suitable location for mounting the controller. It should be a dry, well-ventilated area, protected from direct sunlight, moisture, and corrosive gases. Use the mounting holes on the controller to secure it to a flat surface with the provided screws and anchors.
2. **Battery Connection:** Connect the battery to the controller's battery terminals (labeled 'BATTERY'). Ensure correct polarity: connect the positive (+) terminal of the battery to the positive (+) terminal of the controller, and the negative (-) terminal of the battery to the negative (-) terminal of the controller. This is the FIRST connection to make.
3. **DC Load Connection (Optional):** If you are connecting a DC load directly to the controller, connect it to the load terminals (labeled 'LOAD'). Ensure correct polarity.
4. **Solar Panel Connection:** Connect your solar panels to the controller's solar panel terminals (labeled 'SOLAR'). Ensure correct polarity: connect the positive (+) terminal of the solar array to the positive (+) terminal of the controller, and the negative (-) terminal of the solar array to the negative (-) terminal of the controller.
5. **Remote Temperature Sensor (Optional):** Connect the remote temperature sensor to the designated port on the controller. This allows for accurate battery temperature compensation during charging.
6. **USB and RS485 Ports:** The USB ports can be used for charging compatible devices. The RS485 port is for communication with external monitoring devices (requires additional accessories and software, documentation for which is not included with this manual).

Important Note: Always ensure all connections are tight and secure to prevent loose contacts and potential hazards.

6. OPERATION

Once properly installed, the controller will automatically begin operation. The backlight LCD display provides real-time information about your solar system's performance.

O Layer Display- It will Display All information at One Time, One Screen

Charging Fault

Solar Panel

Solar Panel Volt and Amp

Evening Status

Load Stop Working Hours

Float Charging Voltage

Low Voltage Disconnect Voltage

Battery Capacity and Ambient Temperature

Discharging Fault

Load State

Load Volt and Amp

Battery Volt and Amp

Dawn Status

Low Voltage Reconnect Voltage

TOP SIDE

BOTTOM SIDE

All the Various Real-time data show on one display, convenient user to check

		**Set parameters	*-Set parameters	%	
Toggle key	Charging Fault	"plus"	"Minus"	Temperature battery capacity percentage	Manual switch load

⇐ PV OFF → LOAD OFF → LOAD ON → Evening → Interval → Dawn (Set order Automatic Cycle)

- This button can be "manually" open load or manually close the load
- Long press and hold this button for 5 seconds to restore the factory settings
- "x" error or system failure, click this button, you can troubleshoot or eliminate "x"

Network Line Interface Indicator:

- Green light represents the battery, green light flashes, indicating that the load is working properly
- Yellow light indicates solar energy; yellow light flashes, indicating solar energy charging
- The network interface is reserved for the interface and can be connected to a dedicated display (additional purchase)

Figure 2: LCD Display Details

LCD Display Information:

- **PV:** Solar Panel Voltage and Amperage.
- **BATT:** Battery Voltage and Amperage, Battery Capacity (%).
- **LOAD:** Load Voltage and Amperage, Load State (ON/OFF).
- **Evening/Dawn:** Load stop working hours (Evening) and Load start working hours (Dawn).
- **Interval:** Time interval for load operation.
- **PV OFF:** Voltage at which PV input is disconnected.

- **LOAD OFF:** Voltage at which load is disconnected due to low battery.
- **LOAD ON:** Voltage at which load is reconnected.
- **Charging Fault/Discharging Fault:** Indicators for system errors.

Control Buttons:

- **Toggle Key (Left Arrow):** Used to switch between different display screens and navigate menus.
- **'+' Button:** Used to increase values or move forward in menu options.
- **'-' Button:** Used to decrease values or move backward in menu options.
- **Light Bulb Button:** Manually turns the load output ON or OFF.
- **5S Reset (Light Bulb Button Long Press):** Press and hold the light bulb button for 5 seconds to restore the controller to factory settings. This can also be used to clear certain error indications.

Network Line Indicator:

- **Green Light:** Represents the battery charging status. A solid green light indicates the battery is charging.
- **Yellow Light:** Indicates solar energy charging. A solid yellow light means solar power is actively being converted.

7. MAINTENANCE

Regular maintenance ensures the longevity and optimal performance of your solar charge controller.

- **Inspect Connections:** Periodically check all wiring connections (battery, solar panel, load) for tightness, corrosion, or damage. Loose connections can cause voltage drops, overheating, and system malfunctions.
- **Clean Controller:** Keep the controller's exterior clean and free from dust, dirt, and debris. Use a soft, dry cloth for cleaning. Do not use liquid cleaners.
- **Ventilation Check:** Ensure that the ventilation openings on the controller are not blocked and that there is adequate airflow around the unit to prevent overheating.
- **Battery Health:** Monitor your battery's health and voltage regularly. Ensure the battery type setting on the controller matches your battery type for proper charging.
- **Environmental Conditions:** Protect the controller from extreme temperatures, direct water exposure, and high humidity.

8. TROUBLESHOOTING

This section provides solutions to common issues you might encounter with your charge controller.

Problem	Possible Cause	Solution
---------	----------------	----------

Problem	Possible Cause	Solution
Controller display is off / No power.	Battery not connected or low voltage; reversed battery polarity; loose battery connection.	Check battery connections and ensure correct polarity. Verify battery voltage is above 9V. Tighten all battery terminal connections.
No charging from solar panels.	Solar panels not connected; reversed solar panel polarity; insufficient sunlight; PV input voltage too low/high; damaged solar panel.	Check solar panel connections and polarity. Ensure adequate sunlight. Verify PV input voltage is within the specified range (e.g., 18V-96V for 12V system). Inspect solar panels for damage.
Load output not working or inconsistent.	Load not connected; load overloaded; low battery voltage; load output disabled; internal fault.	Check load connections. Reduce load to within controller's capacity. Charge battery. Ensure load output is enabled via the light bulb button. If issue persists, consider using an external relay for critical loads.
Controller fan is loud or runs excessively.	High current draw; high ambient temperature; restricted airflow.	Ensure proper ventilation around the controller. Check for excessive current draw from solar panels or load. Relocate to a cooler environment if possible.
Error code displayed.	System fault (e.g., over-voltage, over-current, short circuit).	Identify the specific error code on the display. Check corresponding connections and parameters. Long press the light bulb button for 5 seconds to attempt clearing the error. If the error persists, consult the seller.

If you encounter problems not listed here or if the suggested solutions do not resolve the issue, please contact customer support.

9. SPECIFICATIONS

Parameter	Value
Brand	OOYCYOO
Model	60A
System Voltage	12V/24V Auto
Rated Charge Current	60A
Max PV Input Voltage	100V
Max PV Input Power (12V System)	750W

Parameter	Value
Max PV Input Power (24V System)	1500W
Battery Types Supported	LiFePO4, AGM, Sealed, Gel, Flooded
Display Type	LCD
USB Output	2 x 5V 2.4A
Communication Port	RS485
Item Weight	2.99 pounds (1.36 kg)
Package Dimensions	8.4 x 8.3 x 3.3 inches
Manufacturer	OOYCYOO

10. WARRANTY INFORMATION

Specific warranty terms and conditions for the OOYCYOO MPPT Solar Charge Controller 60A may vary depending on your region and point of purchase. Please refer to the warranty information provided with your original purchase documentation or contact your retailer for details regarding warranty coverage, duration, and claims procedures.

11. SUPPORT CONTACT

For technical assistance, product inquiries, or support, please contact your retailer or visit the official OOYCYOO store on Amazon:

[OOYCYOO Store on Amazon](#)

Please have your product model and purchase details ready when contacting support to facilitate a quicker resolution.