



[Manuals.plus](#) /

> [AVLT](#) /

> AVLT Triple Monitor Arm Desk Mount User Manual

**AVLT AVLT-DM26-1**

# AVLT Triple Monitor Arm Desk Mount User Manual

Model: AVLT-DM26-1

## PRODUCT OVERVIEW

---

The AVLT Triple Monitor Arm Desk Mount is designed to enhance your workspace by providing a versatile and ergonomic solution for mounting up to three flat or curved monitors. This full-motion desk mount allows for height, swivel, tilt, and rotation adjustments, helping you achieve an optimal viewing experience and reclaim valuable desk space. It supports monitors ranging from 13 to 27 inches, with a maximum weight capacity of 15.4 lbs per screen.



- Monitor Arm Assembly (includes main pole, arms, VESA plates)
- C-Clamp Mounting Hardware
- Grommet Mounting Hardware
- Installation Tools (e.g., Hex Keys)
- User Manual (this document)
- Cable Management Clips

## SETUP AND INSTALLATION

---

### Pre-Installation Checklist

Before beginning installation, please ensure your monitors meet the following specifications:

- **Monitor Size:** 13" to 27"
- **Monitor Weight:** Under 15.4 lb per screen
- **VESA Mounting Holes:** Your monitor must have a 75x75mm or 100x100mm VESA pattern. If your monitor does not have VESA mounting holes, a separate non-VESA adapter (not included) will be required.

### Mounting Options

The AVLT Triple Monitor Arm Desk Mount offers two primary installation methods:

- **C-Clamp Mount:** Attaches to the edge of your desk. Suitable for desk thicknesses between 0.4" and 1.9" (10-50mm).
- **Grommet Mount:** Utilizes an existing or newly drilled hole in your desk. Suitable for desk thicknesses up to 1.9" (50mm) and grommet hole diameters between 0.4" and 2.3" (10-60mm).



Figure 2: C-Clamp and Grommet Mounting Details

### Assembly Steps

1. **Secure the Base:** Choose either the C-clamp or grommet mount. Attach the base securely to your desk according to the chosen method. Ensure the base is stable and tightened to prevent movement.
2. **Attach the Pole and Arms:** Insert the main pole into the secured base. Then, slide the monitor arms onto the pole. The arms can be positioned at desired heights along the pole.
3. **Mount Monitors:** Attach the VESA plates to the back of your monitors using the provided screws. Once attached, simply hook the VESA plate onto the arm's quick-release tab until it clicks into place.
4. **Cable Management:** Utilize the integrated cable management clips along the arms and pole to route and

conceal your monitor cables. This helps create a clean and organized workspace.

5. **Adjust Height and Tension:** Adjust the height of the monitors along the pole. For optimal movement, adjust the tension of the mechanical spring arms to match the weight of your monitors. This ensures smooth and stable positioning.

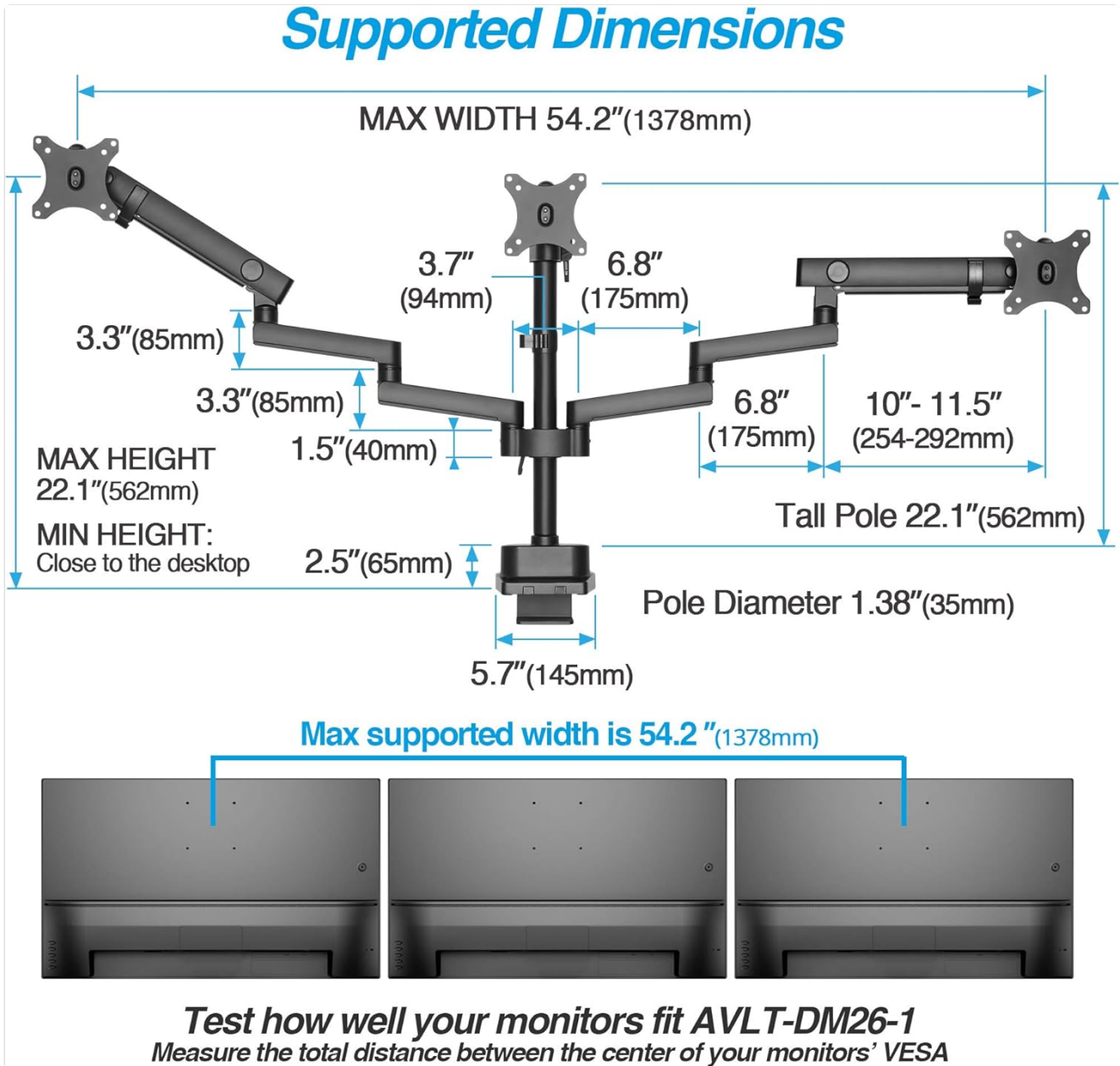

Figure 3: Supported Dimensions and VESA Compatibility



Figure 4: Effortless Adjustment Capabilities (Tilt, Rotation, Swivel)

## OPERATION AND ADJUSTMENT

The AVL T Triple Monitor Arm provides full motion capabilities for a customized viewing experience:

- **Height Adjustment:** Easily raise or lower your monitors along the central pole or via the mechanical spring arms to achieve ergonomic eye-level viewing.
- **Tilt:** Adjust the monitor screen vertically from +90° to -90° to reduce glare and optimize viewing angles.
- **Swivel:** Pivot your monitors horizontally up to +90° to -90° for collaborative work or to share your screen.
- **Rotation:** Rotate your monitors 360° from landscape to portrait orientation, allowing for flexible content display.



Figure 5: Example of a three-monitor setup for enhanced productivity.



Figure 6: Example of a two-monitor setup, demonstrating flexible arrangement.

## MAINTENANCE

---

To ensure the longevity and optimal performance of your AVLT Triple Monitor Arm Desk Mount, follow these simple maintenance guidelines:

- **Cleaning:** Wipe down the mount with a soft, damp cloth. Avoid using abrasive cleaners or solvents that could damage the finish.
- **Periodic Checks:** Periodically check all screws and connections to ensure they remain tight. Re-tighten if necessary.
- **Tension Adjustment:** If monitors begin to sag or are difficult to move, re-adjust the spring tension on the arms as needed. Refer to the assembly steps for guidance.

## TROUBLESHOOTING

---

If you encounter any issues with your monitor arm, please refer to the following common solutions:

- **Monitors are sagging or not holding position:** The spring tension may be too low for the weight of your monitors. Increase the tension using the adjustment screw on the arm until the monitor holds its position.
- **Monitors are difficult to move:** The spring tension may be too high. Decrease the tension until the monitors move smoothly.
- **Mount feels unstable:** Ensure the C-clamp or grommet mount is securely tightened to the desk. Check all connection points on the arms and VESA plates for tightness.
- **Cables are not neatly managed:** Re-route cables through the designated cable management clips and channels on the arms and pole.

If the issue persists, please contact AVLT customer support for assistance.

## PRODUCT SPECIFICATIONS

| Specification           | Detail                             |
|-------------------------|------------------------------------|
| Product Dimensions      | 54.25 x 4.33 x 22.13 inches        |
| Item Weight             | 18.11 pounds                       |
| Manufacturer            | AVLT                               |
| Item Model Number       | AVLT-DM26-1                        |
| Mounting Type           | Tabletop Mount (C-Clamp / Grommet) |
| Movement Type           | Articulating                       |
| Material                | Aluminum                           |
| Maximum Compatible Size | 27 Inches (per monitor)            |
| Minimum Compatible Size | 13 Inches (per monitor)            |
| Compatible Devices      | Monitor                            |
| VESA Compatibility      | 75x75mm, 100x100mm                 |

## WARRANTY AND SUPPORT

The AVLT-DM26-1 Triple Monitor Arm Desk Mount is covered by a **3-YEAR MANUFACTURER WARRANTY** and **LIFETIME TECH SUPPORT**.

For any questions, concerns, or technical assistance, please reach out to AVLT customer support. You can also refer to the official installation manual for more detailed instructions:

[Download Installation Manual  
\(PDF\)](#)