

[Manuals.plus](#) /

> [TAINO](#) /

> TAINO Red 6+1 Gas Barbecue Instruction Manual

TAINO RED 6+1

TAINO Red 6+1 Gas Barbecue Instruction Manual

Model: RED 6+1

Brand: TAINO

1. INTRODUCTION

Thank you for choosing the TAINO Red 6+1 Gas Barbecue. This versatile gas grill is designed to provide an excellent outdoor cooking experience with its large cooking surface and powerful burner system. This manual provides essential information for the safe assembly, operation, maintenance, and troubleshooting of your new barbecue.

Please read this manual thoroughly before assembling or operating the grill. Keep it in a safe place for future reference.



Image: Front view of the TAINO Red 6+1 Gas Barbecue, showcasing its sleek black design and control panel.

2. IMPORTANT SAFETY INFORMATION

Always follow these safety precautions to prevent injury or damage to property.

- **Outdoor Use Only:** This gas barbecue is designed for outdoor use only. Do not operate indoors or in enclosed spaces.
- **Ventilation:** Ensure adequate ventilation around the grill. Do not block any ventilation openings.
- **Gas Leaks:** Before each use, check for gas leaks using a soapy water solution. Never use an open flame to check for leaks.
- **Hot Surfaces:** The grill surfaces become extremely hot during operation. Use heat-resistant gloves and avoid direct contact. Keep children and pets away from the grill.
- **Gas Bottle Connection:** Ensure the gas bottle is securely connected and the regulator is compatible with your local gas supply system. **Note: Some regional gas connections may require specific adapters not included with the grill. Verify compatibility before use.**
- **Clearance:** Maintain a safe distance from combustible materials (e.g., walls, fences, trees).
- **Supervision:** Never leave a lit grill unattended.
- **Cleaning:** Clean the grill regularly to prevent grease buildup, which can cause flare-ups.
- **Storage:** Disconnect the gas bottle and store it in a well-ventilated area when the grill is not in use.

3. PRODUCT COMPONENTS

Your TAINO Red 6+1 Gas Barbecue includes the following main components:

- **Main Burners (6):** Stainless steel burners for primary cooking.
- **Side Burner (1):** Integrated side burner for preparing sauces or side dishes.
- **Cooking Grates:** Two main cooking grates for the grilling surface.
- **Warming Rack:** Elevated rack for keeping food warm or indirect cooking.
- **Lid:** Double-walled insulated lid for optimal heat retention.
- **Control Knobs:** Individual knobs for precise temperature control of each burner.
- **Piezo Ignition:** Integrated ignition system for easy startup.
- **Side Tables:** Two spacious side tables for food preparation and utensils.
- **Lower Cabinet:** Enclosed storage cabinet with doors, designed to hold 5kg and 8kg gas bottles.
- **Removable Grease Tray:** For easy cleaning of drippings.
- **Locking Casters:** Wheels for mobility with locking mechanism for stability.



Image: View of the grill with the lid open, revealing the cooking grates and burner covers.

4. SETUP AND ASSEMBLY

Assembly is required for this product. It is recommended that two people assemble the grill due to its size and weight (approximately 41.4 kg).

4.1 Unpacking and Part Identification

1. Carefully unpack all components from the packaging.
2. Check the parts list provided in the separate assembly guide to ensure all components are present and undamaged.
3. Remove all protective films and packaging materials.

4.2 Assembly Steps

Follow the detailed step-by-step instructions provided in the separate assembly manual. Key steps typically include:

- Attaching the base frame and casters.
- Mounting the main grill body.
- Assembling and attaching the side tables and side burner.
- Installing the cooking grates and warming rack.
- Connecting the gas hose and regulator to the grill and gas bottle. Ensure all connections are tight.

4.3 Initial Burn-Off

Before first use, perform an initial burn-off to eliminate any manufacturing residues. With the lid open, turn all main burners to high for approximately 15-20 minutes. Then, close the lid and continue for another 10 minutes. Allow the grill to cool completely before cleaning the grates.

5. OPERATING INSTRUCTIONS

5.1 Connecting the Gas Bottle

Ensure the gas bottle is placed securely in the lower cabinet. Connect the regulator to the gas bottle and the gas hose to the grill's inlet. Tighten all connections firmly. Perform a leak test with soapy water before lighting.

5.2 Lighting the Main Burners

1. Open the grill lid.
2. Ensure all burner control knobs are in the "OFF" position.
3. Open the valve on your gas bottle.
4. Push in and turn one main burner control knob counter-clockwise to the "HIGH" position.
5. Press the integrated piezo igniter button (if applicable) or use a long-stemmed lighter to ignite the burner.
6. Once the first burner is lit, you can light adjacent burners by pushing in and turning their respective knobs to "HIGH". The flame will spread.
7. Close the lid to preheat the grill to your desired temperature.

5.3 Lighting the Side Burner

1. Open the side burner lid.
2. Push in and turn the side burner control knob counter-clockwise to the "HIGH" position.
3. Press the integrated piezo igniter button or use a long-stemmed lighter to ignite the burner.
4. Adjust the flame as needed.



Image: Detail view of the side burner and its control knob, demonstrating the ignition area.

5.4 Temperature Control

Each burner has an independent control knob, allowing you to adjust the heat from low to high. This enables direct and indirect grilling. The integrated thermometer in the lid helps monitor the internal temperature.



Image: The grill in operation, showing a variety of foods being cooked on the main grates and warming rack.

5.5 Shutting Down the Grill

1. Turn all burner control knobs to the "OFF" position.
2. Close the valve on the gas bottle.
3. Allow the grill to cool completely before cleaning or covering.

6. CARE AND MAINTENANCE

Regular cleaning and maintenance will extend the life of your TAINO gas barbecue.

6.1 Cleaning the Cooking Grates

After each use, once the grill has cooled slightly but is still warm, use a grill brush to scrape off any food residue from the cooking grates. For deeper cleaning, remove the grates and wash with warm soapy water.

6.2 Cleaning the Grease Tray

The removable grease tray should be emptied and cleaned regularly to prevent grease fires. Allow it to cool, then slide it out and dispose of the grease. Wash with warm soapy water.



Image: Detail of the removable grease tray and its collection cup for easy cleaning.

6.3 Exterior Cleaning

Wipe down exterior surfaces with a damp cloth and mild detergent. Avoid abrasive cleaners or steel wool, which can damage the finish. For stainless steel parts, use a specialized stainless steel cleaner.

6.4 Burner Maintenance

Periodically inspect the burner ports for blockages (e.g., from insects or food debris). Clean with a wire brush or a stiff wire if necessary. Ensure the burner tubes are clear.

6.5 Storage

When not in use, especially during off-season, disconnect the gas bottle and store the grill in a dry, sheltered location. Using a grill cover (sold separately) is highly recommended to protect it from weather elements.



Image: The TAINO Red 6+1 Gas Barbecue, illustrating its form factor suitable for a protective cover.

7. TROUBLESHOOTING

This section addresses common issues you might encounter with your gas barbecue.

Problem	Possible Cause	Solution
Burner not lighting	No gas flow, clogged burner port, faulty igniter, empty gas bottle.	Check gas bottle valve, ensure connections are tight, clean burner ports, check igniter electrode, replace gas bottle.
Uneven heating	Clogged burner ports, uneven flame, wind.	Clean burner ports, adjust flame settings, position grill away from strong winds.
Gas smell	Gas leak.	Immediately turn off gas supply. Perform a leak test with soapy water. If leak persists, do not use and contact qualified service personnel.
Rust appearing on surfaces	Exposure to moisture, lack of regular cleaning/maintenance.	Clean affected areas, apply rust-inhibiting treatment if suitable for grill materials, ensure grill is covered and stored in a dry place.

If you encounter issues not listed here or if solutions do not resolve the problem, please contact TAINO customer

support.

8. TECHNICAL SPECIFICATIONS

Model:	RED 6+1
Brand:	TAINO
Overall Dimensions (L x H x D):	Approx. 146 x 114 x 54 cm
Cooking Surface Dimensions:	Approx. 77 x 42 cm
Weight:	41.4 kg
Number of Burners:	6 Main Burners + 1 Side Burner
Fuel Type:	Gas
Material:	Metal (Steel), Stainless Steel Finish
Special Features:	Enclosed cabinet, removable grease tray, warming rack, locking casters, piezo ignition, double-walled lid.

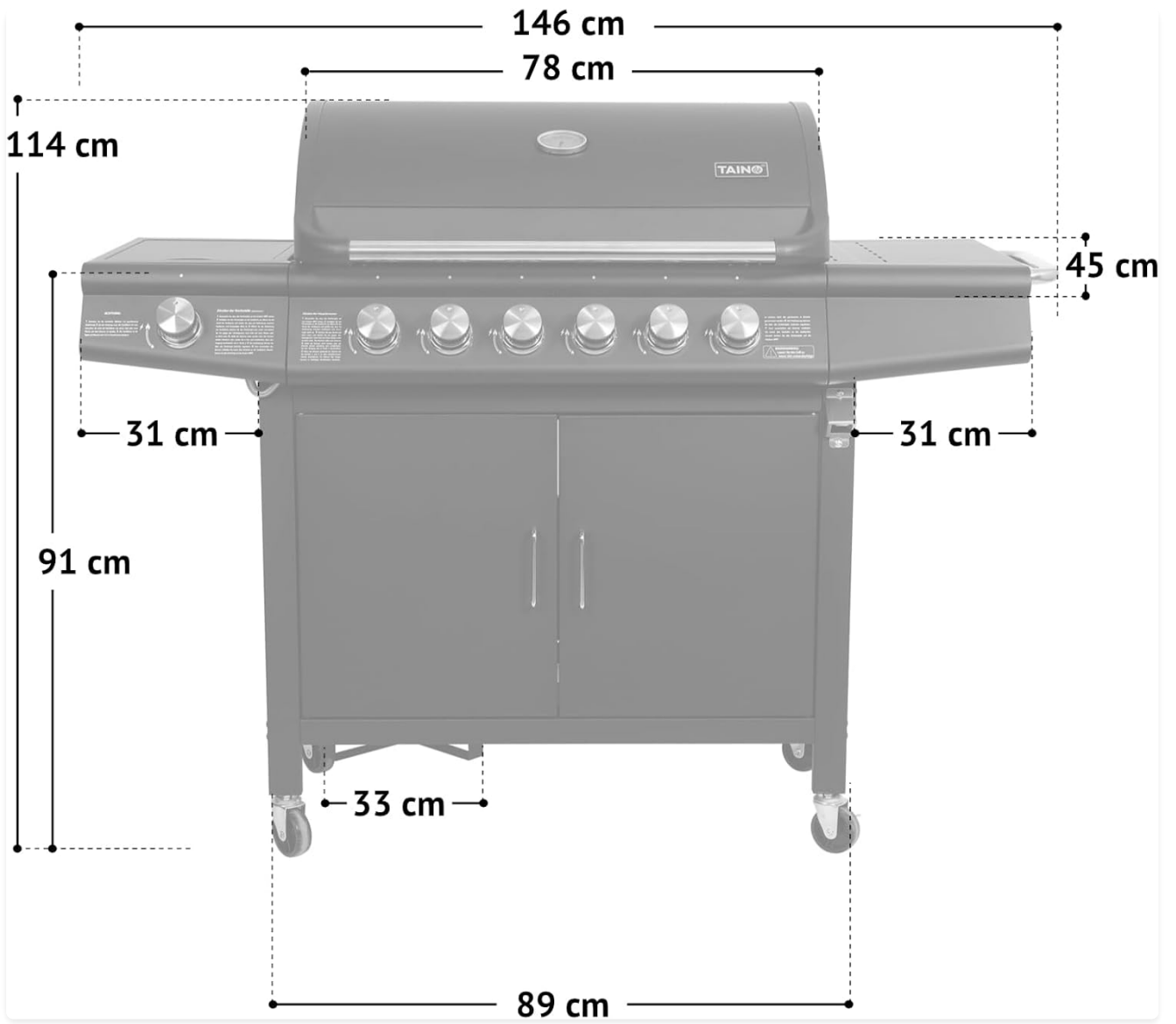

Image: Technical diagram illustrating the overall dimensions of the barbecue.

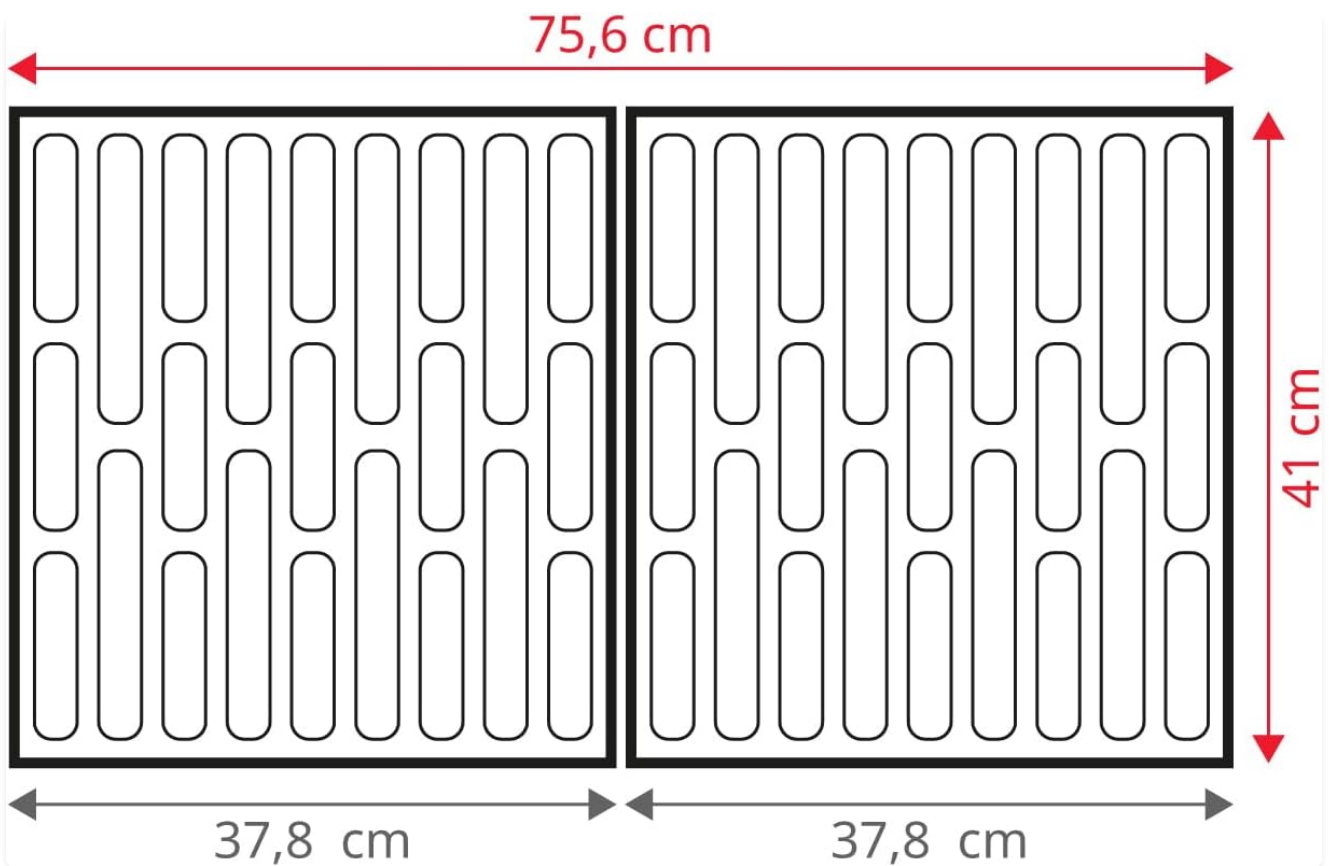

Image: Technical diagram illustrating the dimensions of the cooking grates.

9. WARRANTY INFORMATION

Warranty terms and conditions for the TAINO Red 6+1 Gas Barbecue are typically provided at the point of purchase or can be found on the manufacturer's official website. Please retain your proof of purchase for any warranty claims. For specific details regarding coverage and duration, refer to the documentation included with your product or contact the retailer.

10. CUSTOMER SUPPORT

For technical assistance, spare parts, or any questions regarding your TAINO Red 6+1 Gas Barbecue, please contact the retailer where you purchased the product or visit the official TAINO website for support contact information.

Manufacturer: Clic-Trade GmbH

Please have your model number (RED 6+1) and purchase date ready when contacting support.