

## KeeYees KYES505-10

# KeeYees 4-Channel IIC I2C Logic Level Converter Module User Manual

Model: KYES505-10

## 1. INTRODUCTION

---

The KeeYees 4-Channel Bi-Directional Logic Level Converter Module is designed to safely interface devices operating at different voltage levels. This module allows for seamless communication between 3.3V and 5V systems, converting signals in both directions. It is particularly useful for microcontrollers like Arduino (5V) and ESP32/Raspberry Pi (3.3V) when communicating via protocols such as IIC (I2C).

Each module provides four independent channels for logic level conversion. The package includes the converter modules and pin headers for easy integration into your projects.

## 2. PACKAGE CONTENTS

---

- 10 x KeeYees 3.3V-5V 4 Channels Logic Level Converter Bi-directional Shifter Module
- 20 x 6-Pin Single Row Pin Headers

## 3. SETUP AND CONNECTION

---

The logic level converter requires power from both the high voltage (HV) and low voltage (LV) systems it is connecting. Ensure proper grounding for stable operation.

### 3.1 Pinout Diagram

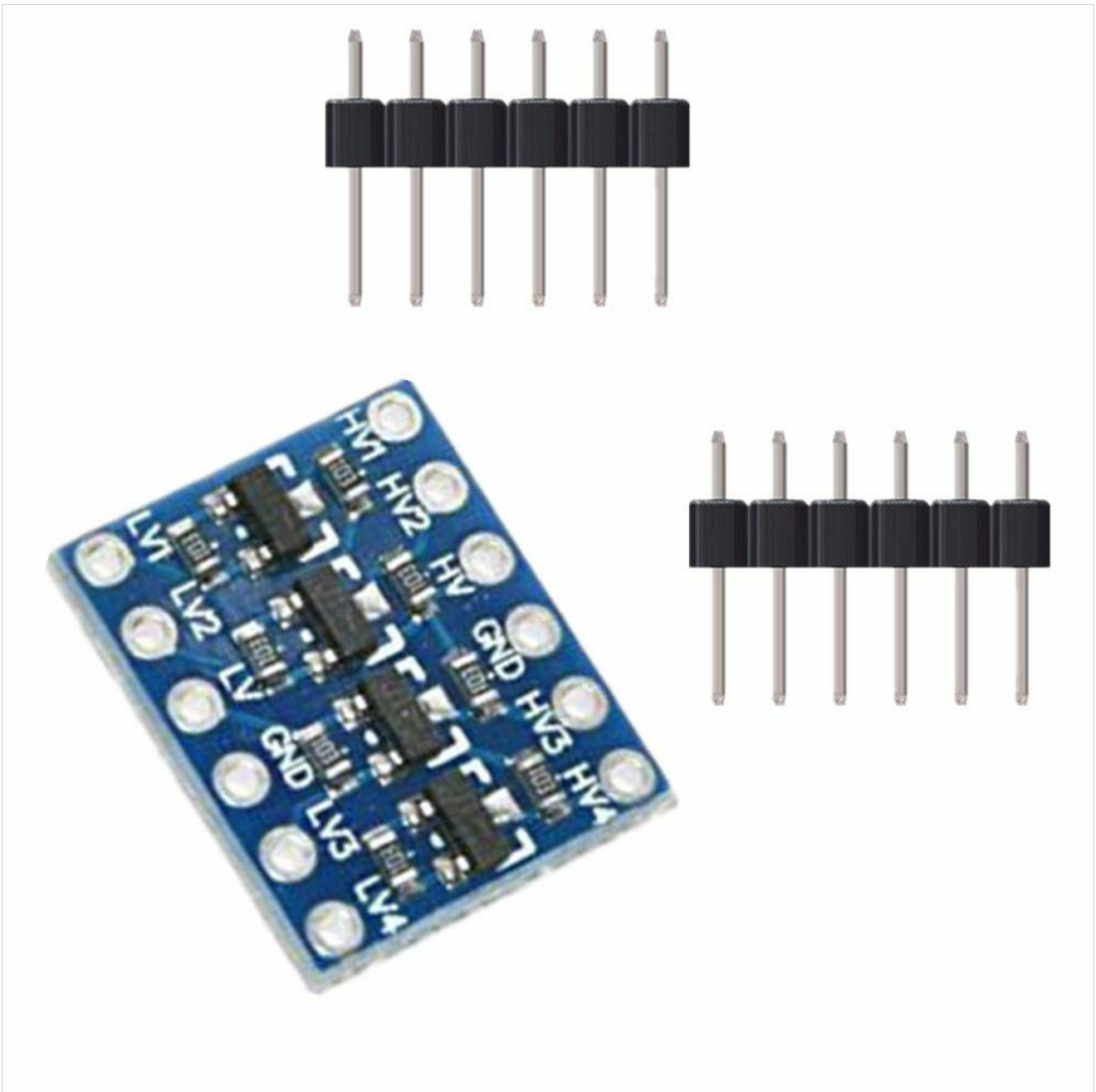

Figure 1: Top view of the KeeYees 4-Channel Logic Level Converter module showing pin labels for High Voltage (HV), Low Voltage (LV), and Ground (GND) connections.

### 3.2 Connection Steps

1. **Connect High Voltage (HV) Power:** Connect the 5V power supply from your high-voltage system (e.g., Arduino) to the **HV** pin on the converter module.
2. **Connect Low Voltage (LV) Power:** Connect the 3.3V power supply from your low-voltage system (e.g., ESP32, Raspberry Pi) to the **LV** pin on the converter module.
3. **Connect Ground:** Connect the common ground from both your high-voltage and low-voltage systems to the **GND** pin on the converter module. There are two GND pins, either can be used.
4. **Connect Logic Signals:**
  - o For signals from the high-voltage system (e.g., 5V output from Arduino) that need to be converted to low voltage (3.3V input for ESP32), connect the 5V signal to an **HVx** pin (e.g., HV1). The corresponding **LVx** pin (e.g., LV1) will output the 3.3V converted signal.
  - o For signals from the low-voltage system (e.g., 3.3V output from ESP32) that need to be converted to high voltage (5V input for Arduino), connect the 3.3V signal to an **LVx** pin (e.g., LV2). The corresponding **HVx** pin (e.g., HV2) will output the 5V converted signal.

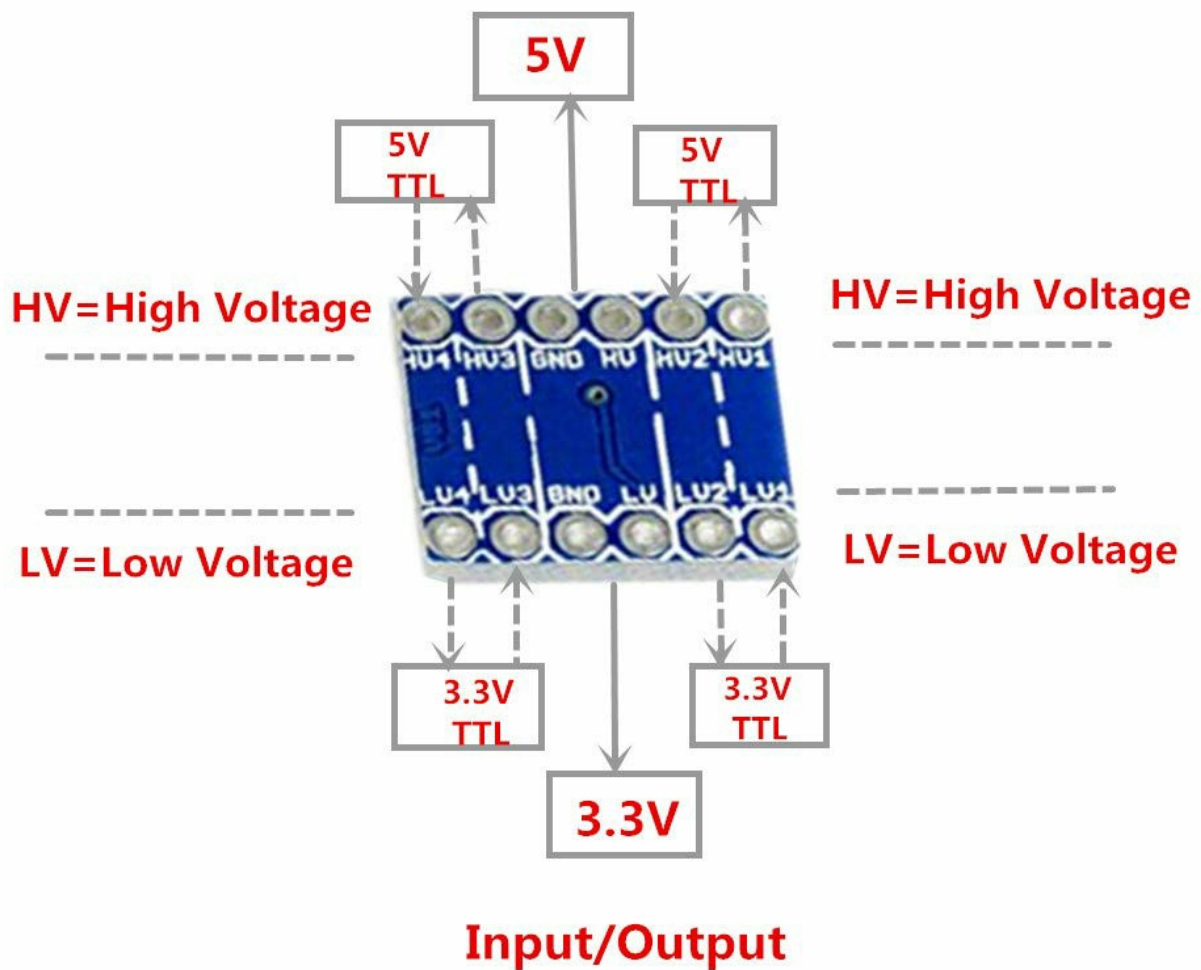

Figure 2: Illustrative diagram showing typical connections for the logic level converter, demonstrating how 5V and 3.3V TTL signals are interfaced between HV and LV sides.

#### 4. OPERATING PRINCIPLES

The KeeYees logic level converter utilizes a bi-directional design, meaning it can translate signals from high voltage to low voltage and vice-versa simultaneously on the same channel. This is achieved using MOSFETs (Metal-Oxide-Semiconductor Field-Effect Transistors) and pull-up resistors.

- When a low-voltage signal (e.g., 3.3V) is applied to the LV side, the module steps it up to the high-voltage level (e.g., 5V) on the HV side.
- Conversely, when a high-voltage signal (e.g., 5V) is applied to the HV side, it is safely stepped down to the low-voltage level (e.g., 3.3V) on the LV side.
- The module supports common digital communication protocols such as IIC (I2C), SPI, and UART, making it versatile for various embedded projects.

#### 5. MAINTENANCE

The KeeYees logic level converter module is a robust electronic component designed for long-term use with minimal maintenance. To ensure optimal performance and longevity:

- **Keep Clean:** Avoid dust, dirt, and moisture accumulation on the module. If cleaning is necessary, use a soft, dry brush or a lint-free cloth. Do not use liquid cleaners.
- **Handle with Care:** Avoid applying excessive force to the pins or the board itself. Electrostatic discharge (ESD) can damage electronic components; handle the module in an ESD-safe environment if possible.
- **Proper Storage:** Store the module in a dry, cool environment, away from direct sunlight and extreme temperatures.
- **Inspect Connections:** Periodically check all soldered connections and pin headers for looseness or corrosion, especially in projects that experience vibration or frequent handling.

## 6. TROUBLESHOOTING

---

If you encounter issues while using the logic level converter, consider the following troubleshooting steps:

- **No Signal Conversion:**
  - Verify that both the HV and LV power supplies are correctly connected and providing the specified voltages (e.g., 5V to HV, 3.3V to LV).
  - Ensure that the common ground (GND) is properly connected between the converter and both systems.
  - Check all signal connections (HVx to LVx) for continuity and correct pin assignment.
- **Slow Signal Response / Data Errors:**
  - For high-speed applications (e.g., fast I2C or SPI), ensure that appropriate pull-up resistors are used on the HV side if not already present in your circuit. The internal pull-ups on the converter might be sufficient for standard speeds but not for very high frequencies.
  - Keep wire lengths as short as possible to minimize signal degradation and noise.
  - The module's design (using MOSFETs) can introduce a slight delay or slower rise times compared to active buffer solutions. For extremely critical timing applications, consider alternative level shifting methods.
- **Module Not Powering On:**
  - Double-check power connections to HV, LV, and GND pins.
  - Ensure your power supplies are functional and delivering the correct voltage and sufficient current.
- **Physical Damage:** Inspect the module for any visible signs of damage, such as bent pins, burnt components, or cracked solder joints.

## 7. SPECIFICATIONS

---

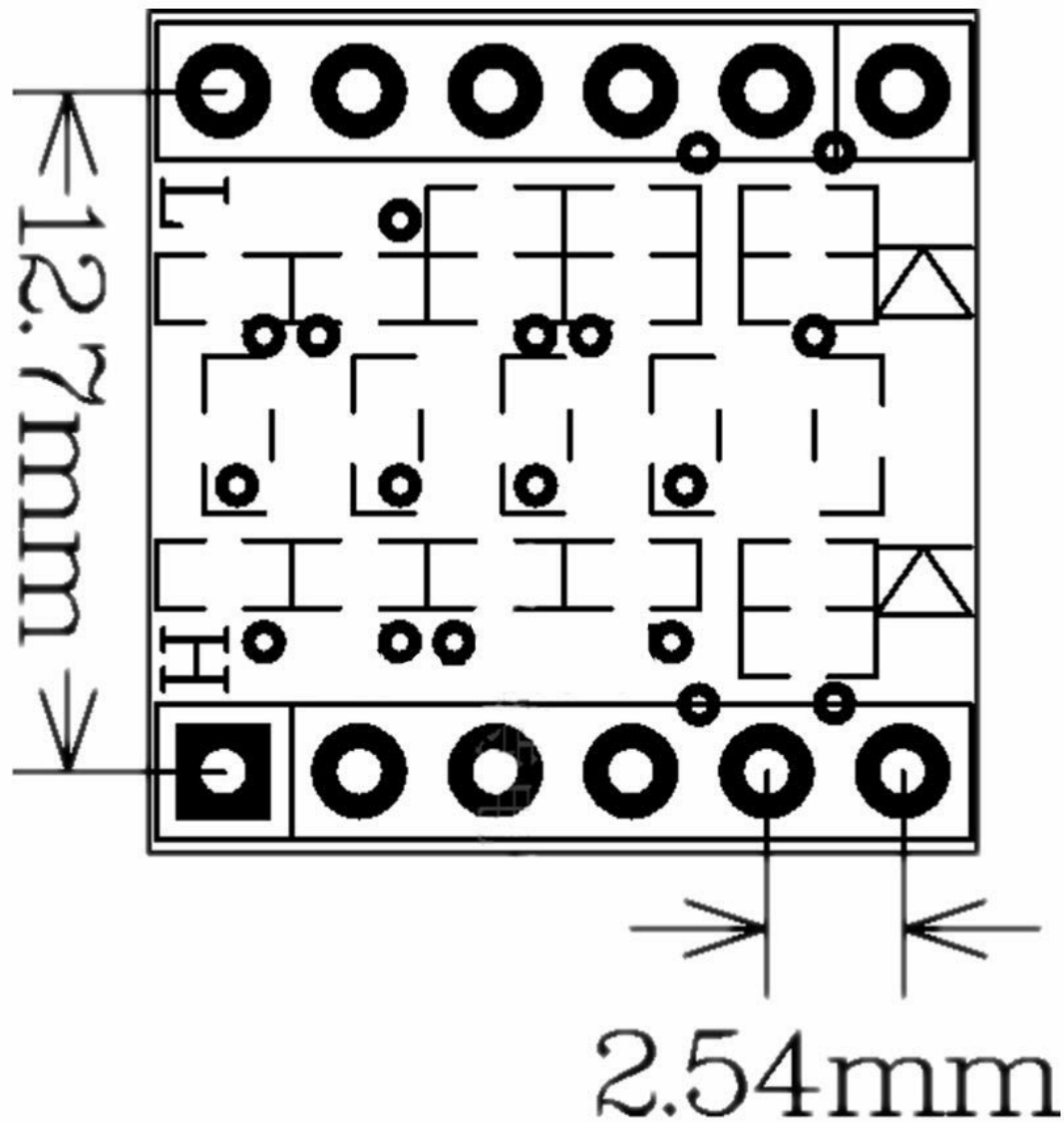

Figure 3: Dimensional drawing of the KeeYees 4-Channel Logic Level Converter module, indicating key measurements such as 12.7mm width and 2.54mm pin pitch.

Feature	Value
Brand	KeeYees
Model Number	KYES505-10
Maximum Supply Voltage	5 Volts
Minimum Supply Voltage	3.3 Volts
Number of Channels	4
Interface	I2C (IIC) compatible
Mounting Type	Through-hole (for pin headers)
Dimensions	Approx. 12.7mm width (refer to Figure 3 for details)

## 8. WARRANTY AND SUPPORT

---

Specific warranty information for the KeeYees 4-Channel IIC I2C Logic Level Converter Module is not provided in the available product data. For details regarding warranty coverage, returns, or technical support, please refer to the official KeeYees website or contact the seller directly through your purchase platform.

You can often find support resources and contact information on the [KeeYees Store on Amazon](#).