



Manuals.plus /

› Rancilio /

› Rancilio Classe 5 Commercial Espresso Machine User Manual

## Rancilio Classe 5 USB1 Group

# Rancilio Classe 5 Commercial Espresso Machine

Model: Classe 5 USB1 Group

## PRODUCT OVERVIEW

---

The Rancilio Classe 5 USB1 Group is an entry-level to mid-range traditional espresso machine, combining modern style with contemporary design. Constructed from brushed stainless steel, ABS, and nylon panels, this machine is built for durability and performance in commercial settings.

Key features include soft touch keypads with programmable drink volumes, independent heat exchangers, a built-in volumetric pump, and a 4-liter boiler. It also features a USB port for easy management of machine parameters and an ergonomic C-Lever steam wand for efficient milk frothing.



Figure 1: Front view of the Rancilio Classe 5 Commercial Espresso Machine, showcasing its sleek design and control panel.

## SETUP AND INSTALLATION

---

Proper installation is crucial for the optimal performance and longevity of your Rancilio Classe 5 espresso machine. Please follow these guidelines carefully.

### Space Requirements

Ensure adequate space for the machine, considering its dimensions and the need for ventilation and access for maintenance.

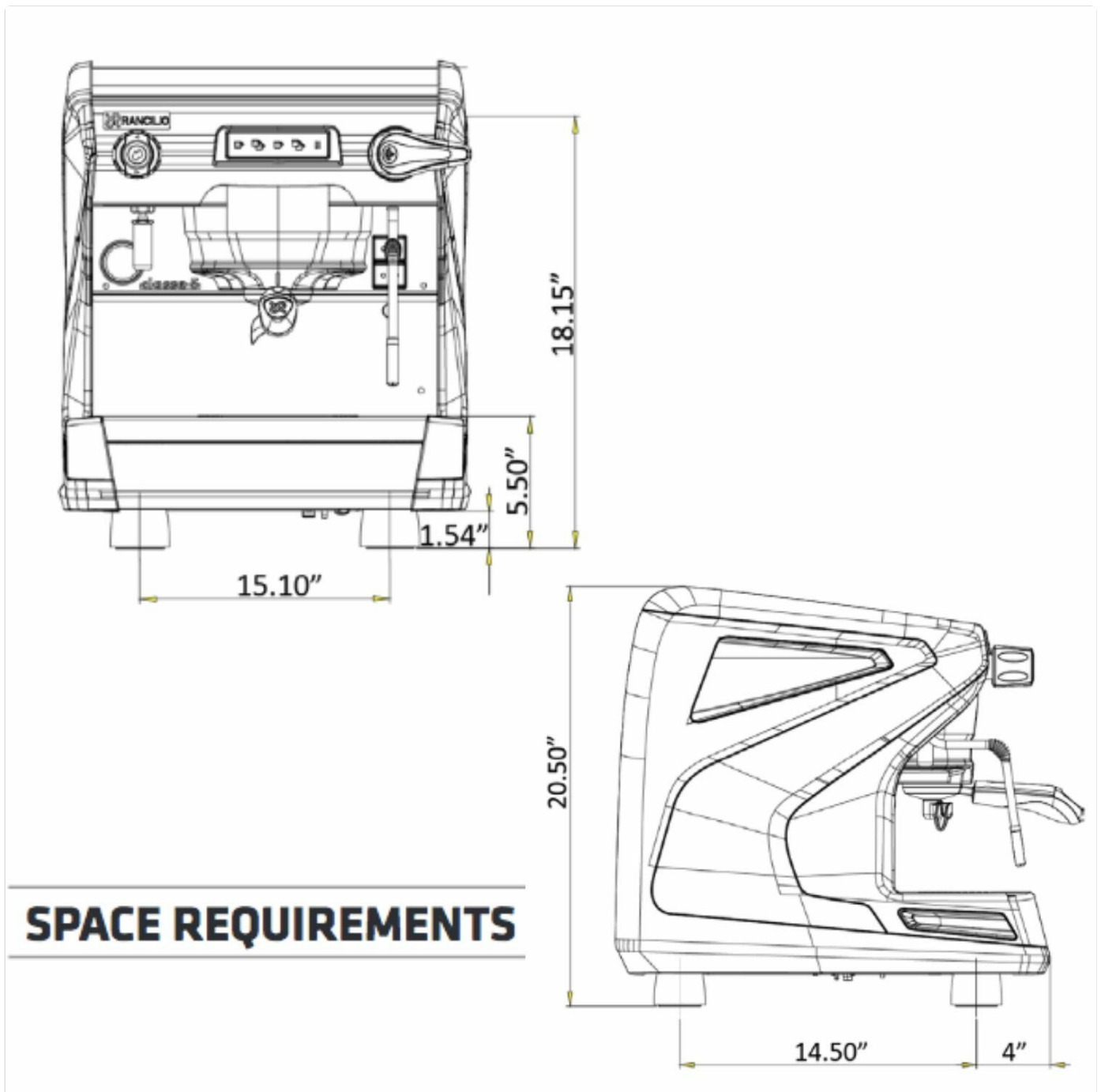

Figure 2: Dimensional diagram illustrating the space requirements for the Rancilio Classe 5 machine. Dimensions are approximately 16 inches wide x 22 inches deep x 21 inches high.

### Electrical Connections

The machine requires a dedicated electrical circuit. Refer to the specifications for voltage and amperage requirements.

- **Voltage Range:** 110 - 120 V
- **Watts:** 1600 W
- **Circuit Size:** 15 amps
- **Suggested Receptacle:** 15a GFI or 5-15R

# SERVICE CONNECTIONS

## ELECTRICAL CONNECTIONS:

### 1 GROUP

**Voltage Range:** 110 - 120 V

**Watts:** 1600

**Circuit Size:** 15 amps

**Suggested Receptacle:**

15a GFI or 5-15R

Receptacle for Espresso Machine

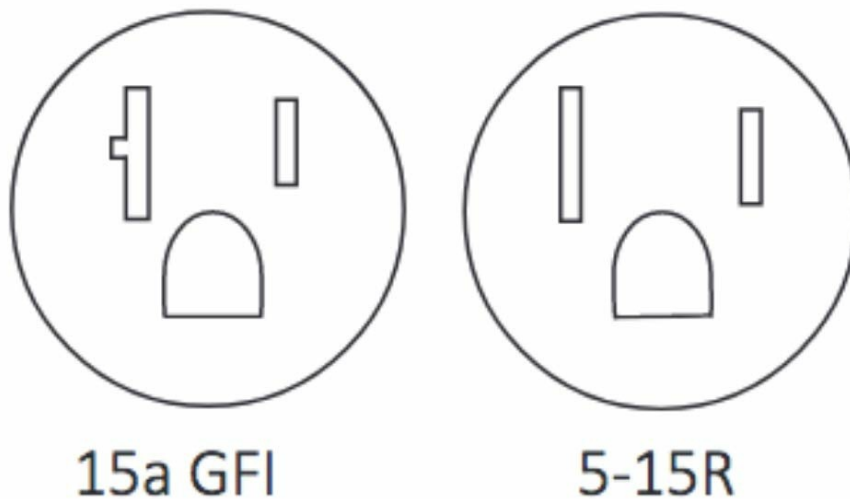

Figure 3: Electrical connection diagram showing recommended 15a GFI and 5-15R receptacles suitable for the espresso machine.

### Water Connection

A dedicated cold water access line with a standard female 3/8" NPT fitting and a manual shut-off valve is required within 4 feet of the machine.

### Drain Connection

An open gravity drain with a minimum 2" I.D. is required within 4 feet of the machine for proper drainage.

## OPERATING INSTRUCTIONS

Familiarize yourself with the machine's controls and functions for optimal coffee preparation.

### Control Panel and Programming

The Classe 5 USB1 features soft touch keypads with white LED backlights. These keypads allow for easy start and stop controls and offer 4 programmable drink volumes for quick and consistent espresso preparation.



Figure 4: A hand interacting with the soft touch control panel of the Rancilio Classe 5, demonstrating the ease of operation for programming drink volumes.

The USB port allows for easy management of machine parameters, enabling customization and updates.

### **Espresso Preparation**

The heat exchange system allows for simultaneous espresso extraction and milk steaming. Use the double spout portafilter for serving.



## RANCILIO CLASSE 5 USB1 GROUP

ENTRY LEVEL TO MID RANGE TRADITIONAL ESPRESSO MACHINE



Figure 5: Close-up view of espresso being dispensed from the Rancilio Classe 5 into two cups, highlighting the machine's brewing capability.

### Steaming Milk

The manual steam wand features a C-Lever ergonomically designed handle with two positions: pulse steam (down) or steam fully on (up). This allows for precise control when frothing and steaming milk.

### Hot Water Dispensing

The machine is equipped with a hot water outlet controlled by a manual valve knob.

## MAINTENANCE AND CLEANING

---

Regular maintenance ensures the longevity and consistent performance of your espresso machine.

### Daily Cleaning

The intelligent management of the brewing button provides fully automatic group cleaning. An LED light on the control panel indicates when routine maintenance is needed. This function helps maintain extraordinary brew quality and reduces

daily cleaning times.

## Drain Insert Cleaning

The scratch-proof polymer drain insert is removable and dishwasher safe, making it easy to clean.

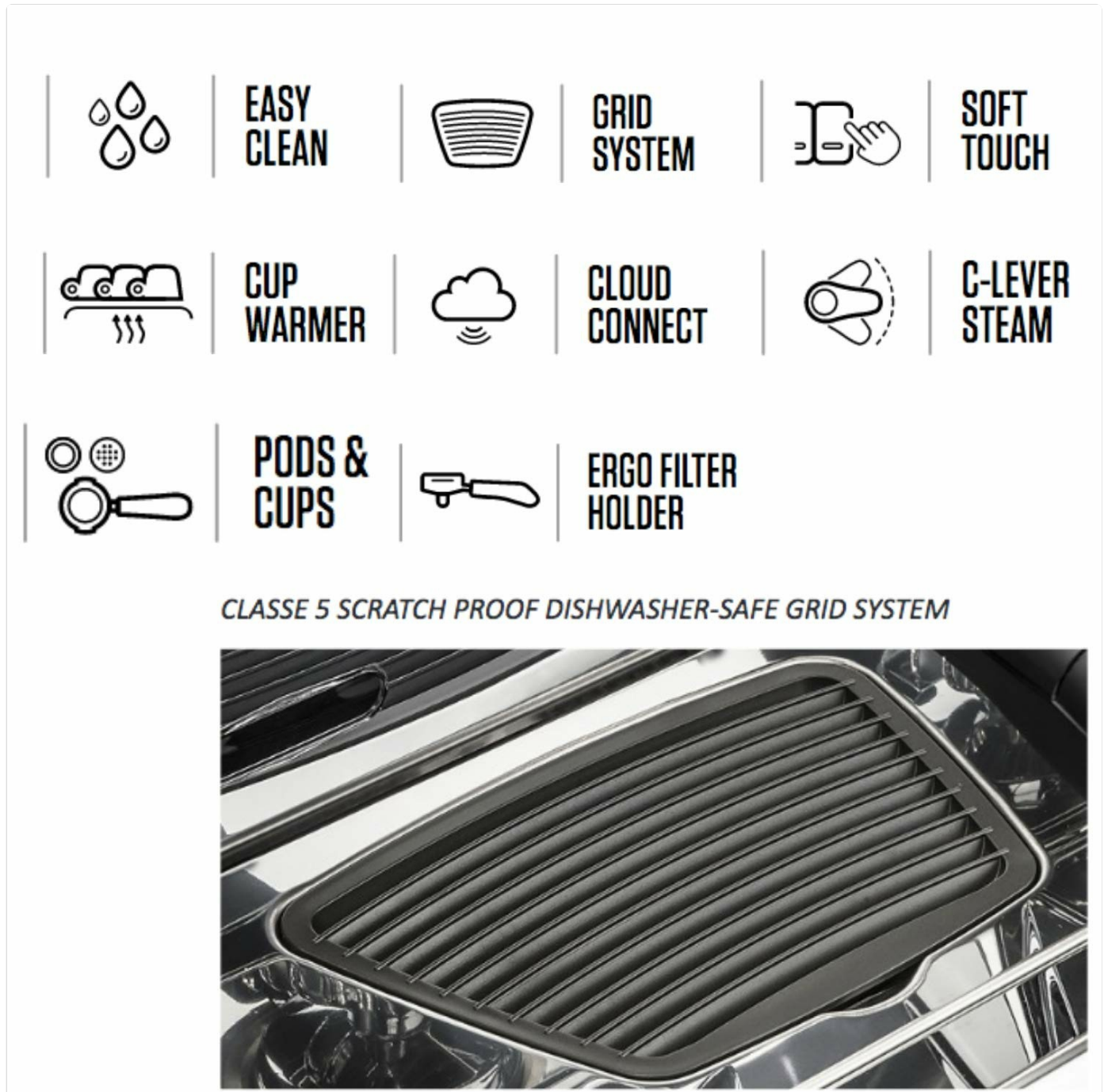

### *CLASSE 5 SCRATCH PROOF DISHWASHER-SAFE GRID SYSTEM*

Figure 6: A close-up of the Classe 5 scratch-proof dishwasher-safe grid system (drain insert), alongside icons representing key features like Easy Clean, Grid System, Soft Touch, Cup Warmer, Cloud Connect, C-Lever Steam, Pods & Cups, and Ergo Filter Holder.

## General Care

Wipe down the exterior with a damp cloth. Do not use abrasive cleaners. Periodically check and clean the steam wand and hot water spout to prevent blockages.

## TROUBLESHOOTING

This section provides solutions to common issues you might encounter with your Rancilio Classe 5 espresso machine.

- **No Power:** Ensure the machine is properly plugged into a functioning 15a GFI or 5-15R outlet and the circuit

breaker has not tripped.

- **No Water Flow:** Check the water supply line connection and ensure the manual shut-off valve is open. Verify that the water reservoir (if applicable to your model variant) is filled.
- **Poor Espresso Extraction:** This can be due to incorrect grind size, improper tamping, or a dirty group head. Adjust grind, ensure consistent tamping pressure, and perform a group cleaning cycle.
- **Steam Wand Issues:** If the steam wand is not producing adequate steam, check for blockages in the nozzle and ensure the boiler has reached optimal temperature.
- **Error Indicators:** If an LED light on the control panel indicates a maintenance need, follow the recommended cleaning or service procedures.

For issues not covered here, or if problems persist, please contact authorized service personnel.

## TECHNICAL SPECIFICATIONS

---

Feature	Detail
Brand	Rancilio
Model Name	Classe 5 USB1 Group
Colour	Black
Coffee Maker Type	Espresso Machine
Operation Mode	Semi Automatic
Voltage	110-120 Volts
Power	1600 Watts
Boiler Capacity	4 Liters
Pump Type	Built-in Volumetric Pump
Dimensions (W x D x H)	Approx. 16" x 22" x 21"
Item Weight	33 kg 100 g
Water Connection	Dedicated cold water line, 3/8" NPT fitting
Drain Connection	Open gravity drain, min 2" I.D.
Control Interface	Soft Touch Keypads, USB Port
Steam Wand	Manual, C-Lever ergonomic design
Included Components	Semi Automatic Coffee Machine, Double spout portafilter

## WARRANTY AND SUPPORT

---

### Warranty Information

This Rancilio Classe 5 Commercial Espresso Machine comes with a **1 Year Warranty** from the date of purchase. Please retain your proof of purchase for warranty claims.

### Customer Support

For technical assistance, troubleshooting, or warranty service, please contact your authorized Rancilio dealer or the manufacturer's customer support. Refer to your purchase documentation for specific contact details.