

BONTEC Mobile TV Stand B07HHVXDDL

BONTEC Mobile TV Stand Instruction Manual

Model: Mobile TV Stand B07HHVXDDL

1. PRODUCT OVERVIEW

The BONTEC Mobile TV Stand is designed to provide a versatile and adjustable viewing solution for your television. It accommodates a wide range of TV sizes and features mobility, height adjustment, and a media shelf for convenience.

Key Features:

- **Wide TV & VESA Compatibility:** Supports most 32-85 inch LED, LCD, OLED, and Plasma TVs with a maximum weight capacity of 60 kg. Compatible with VESA patterns from 50x50 mm to 600x400 mm.
- **Fully Adjustable Height & Tilt:** The mounting bracket offers 15° tilt up and down for optimal viewing angles and 8 height adjustment levels from 1016.5 mm to 1517 mm (adjustable in 71.5 mm steps). An adjustable media shelf is included for laptops and gaming systems.
- **Smooth Mobility with Lockable Wheels:** Equipped with four durable 360° swivel wheels, including two lockable wheels for stability. Easily move your TV cart between different rooms and locations.
- **Integrated Cable Management System:** Neatly conceals cables to keep your setup organized. Features a stable steel frame with a durable, stylish finish for maximum safety and long-lasting use.
- **Quick and Easy Assembly:** Includes all necessary tools and instructions for a hassle-free installation.

2. SAFETY INFORMATION

WARNING: Failure to read and follow these instructions can result in serious personal injury, property damage, or voiding of your warranty.

- Do not exceed the maximum weight capacity of 60 kg (132 lbs) for the TV bracket and 10 kg (22 lbs) for the media shelf.
- Ensure your TV's VESA pattern is compatible (Min: 50x50 mm, Max: 600x400 mm).
- Always use the locking wheels to secure the stand in place when not moving it.
- Assemble the product on a soft, non-abrasive surface to avoid scratches.

- Keep children and pets away during assembly.
- If any parts are missing or damaged, contact customer support immediately. Do not attempt to assemble with damaged parts.
- This product is intended for indoor use only.

3. SETUP AND ASSEMBLY

Follow these steps carefully to assemble your BONTEC Mobile TV Stand.

3.1 Unpacking and Parts Identification

Carefully unpack all components and verify against the parts list (not provided in this manual, refer to your product packaging). Ensure all parts are present and undamaged.

3.2 Base Assembly

Attach the wheels to the base of the stand. Ensure they are securely fastened. The base is designed for stability and mobility.

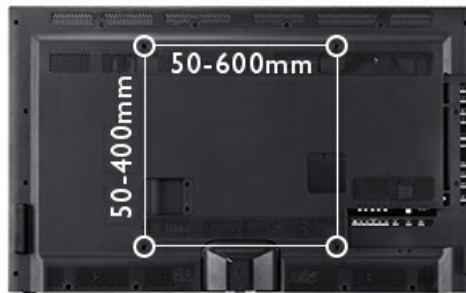

Image: Illustration of the stand's base with wheels.

3.3 Column Assembly

Connect the vertical columns to the base. The columns are designed to interlock securely. Use the provided fasteners to ensure a stable connection.



Image: Adjustable stand TV stand with mounting bracket for flat-screen TVs.

3.4 Media Shelf Installation

Attach the media shelf to the main column at your desired height. This shelf is adjustable and can hold devices up to 10 kg.

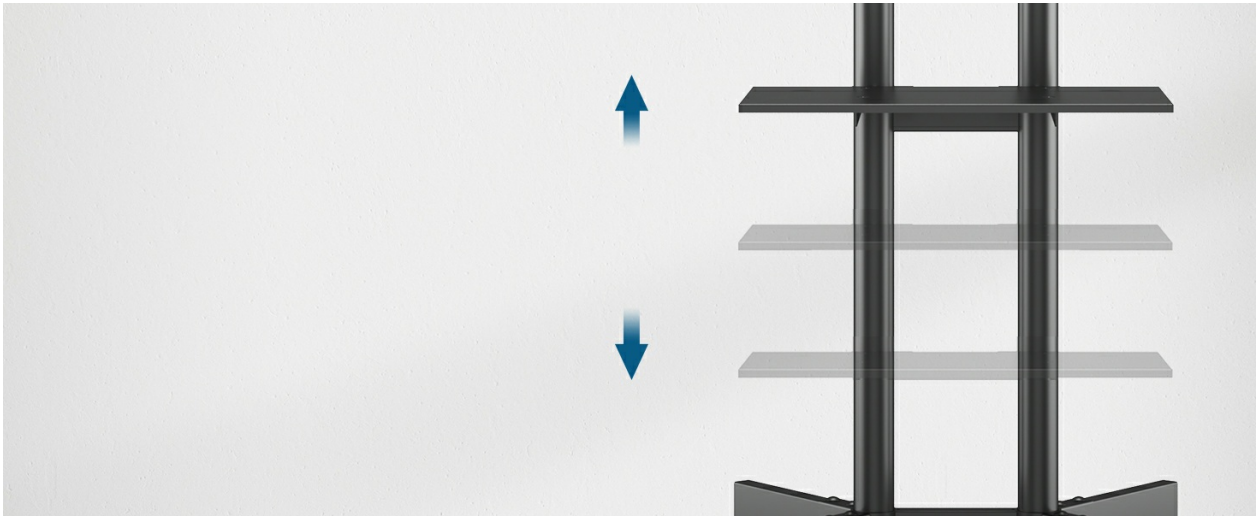

Image: The media shelf attached to the stand, demonstrating cable management.

3.5 TV Mounting Bracket Installation

Attach the TV mounting bracket to the top of the main column. Ensure it is oriented correctly for your TV's VESA pattern.

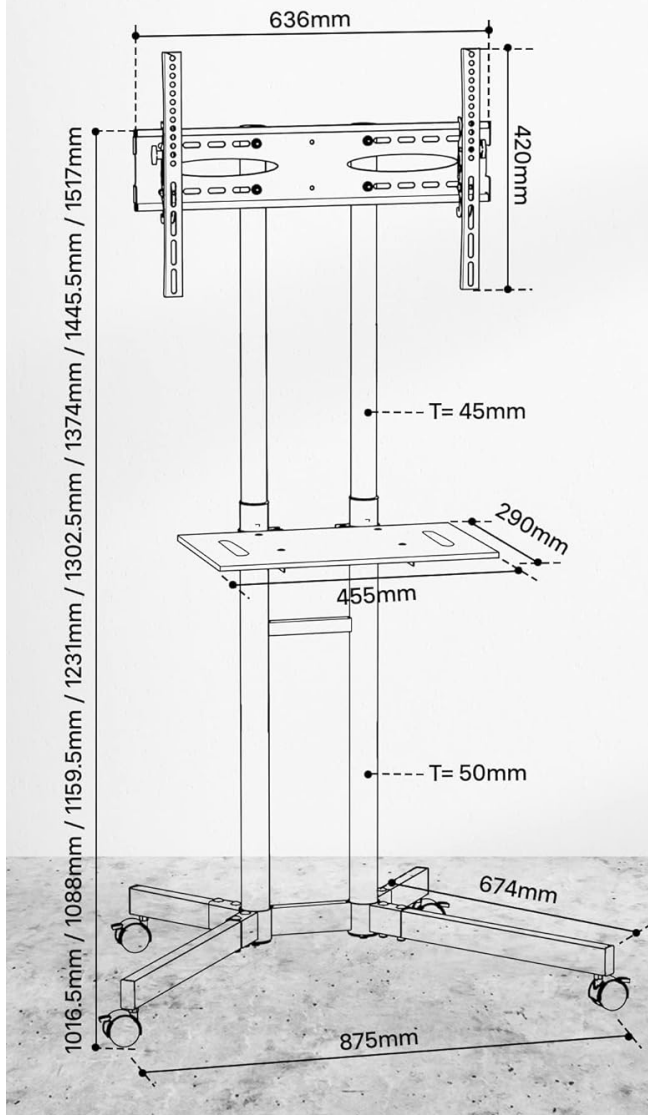

Image: Mounting diagram of the articulated TV wall mount, showing various angles and positions.

3.6 Attaching the TV

Carefully attach your TV to the mounting bracket. Ensure the VESA screws are compatible and tightened securely. This stand supports VESA patterns from 50x50mm to 600x400mm.

◆ Compatible with 32"-85" Screen



NEED YOUR ATTENTION

If your TV screen is less than 636 x 420 mm, the TV mounting arms will protrude from behind the TV.

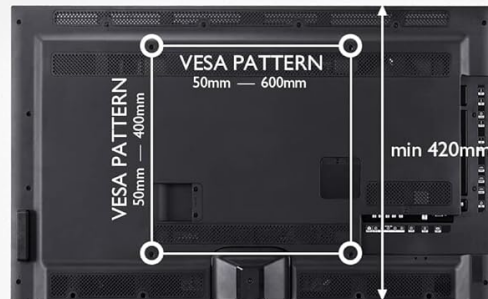

VESA Patterns

Min: 50x50 mm
Max: 600x400 mm

Bracket Weight Capacity

60kg / 132lbs

Shelf Weight Capacity

10kg / 22lbs

Image: Diagram illustrating VESA patterns (Min: 50x50 mm, Max: 600x400 mm), bracket weight capacity (60 kg), and shelf weight capacity (10 kg).

3.7 Assembly Video Guide

For a visual guide on assembly, please refer to the official installation video:

Your browser does not support the video tag.

Video: *BONTEC Mobile TV Stand Installation Video*. This video demonstrates the step-by-step assembly process of the TV stand.

4. OPERATING INSTRUCTIONS

This section details how to use the features of your BONTEC Mobile TV Stand.

4.1 Height Adjustment

The TV mounting plate can be adjusted to 8 different height levels, ranging from 1016.5 mm to 1517 mm, in 71.5 mm increments. Loosen the adjustment screws, set to the desired height, and re-tighten securely.

◆ Height Adjustment for Perfect Viewing Position

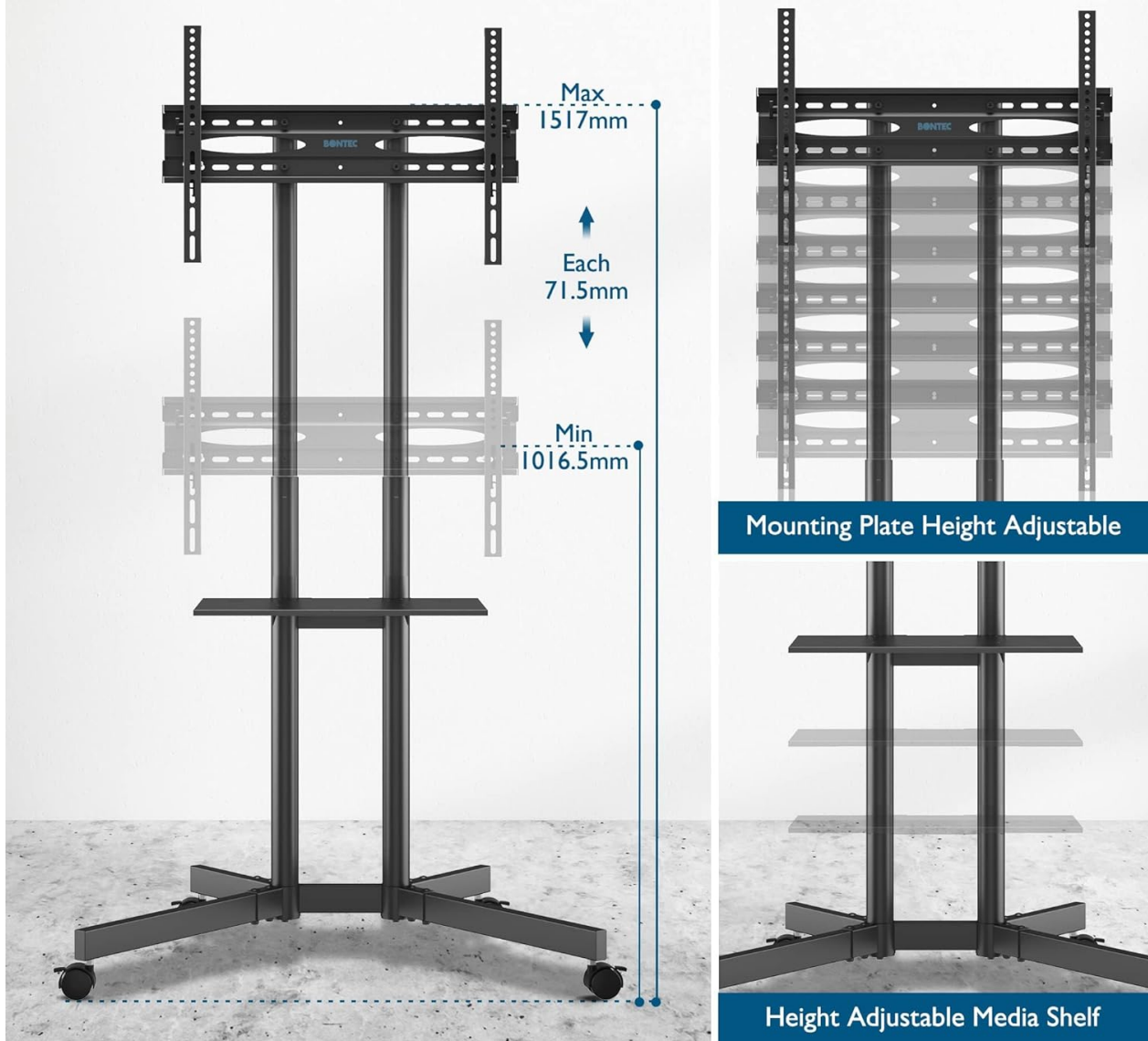

Image: Diagram illustrating the height adjustment range for the TV mounting plate (Min 1016.5mm, Max 1517mm) and the adjustable media shelf.

4.2 TV Tilt Adjustment

The TV bracket allows for a tilt of up to 15 degrees both upwards and downwards. This feature helps in achieving an optimal viewing angle and reducing glare. Adjust the tilt mechanism located on the bracket and secure it.



Image: A mobile TV stand in an office setting, demonstrating the 15-degree tilt capability for an expanded viewing angle.

4.3 Mobility and Locking Wheels

The stand is equipped with four 360° swivel wheels for easy movement. Two of these wheels are lockable. To move the stand, unlock the wheels. To secure the stand in a stationary position, engage the locks on the two lockable wheels.

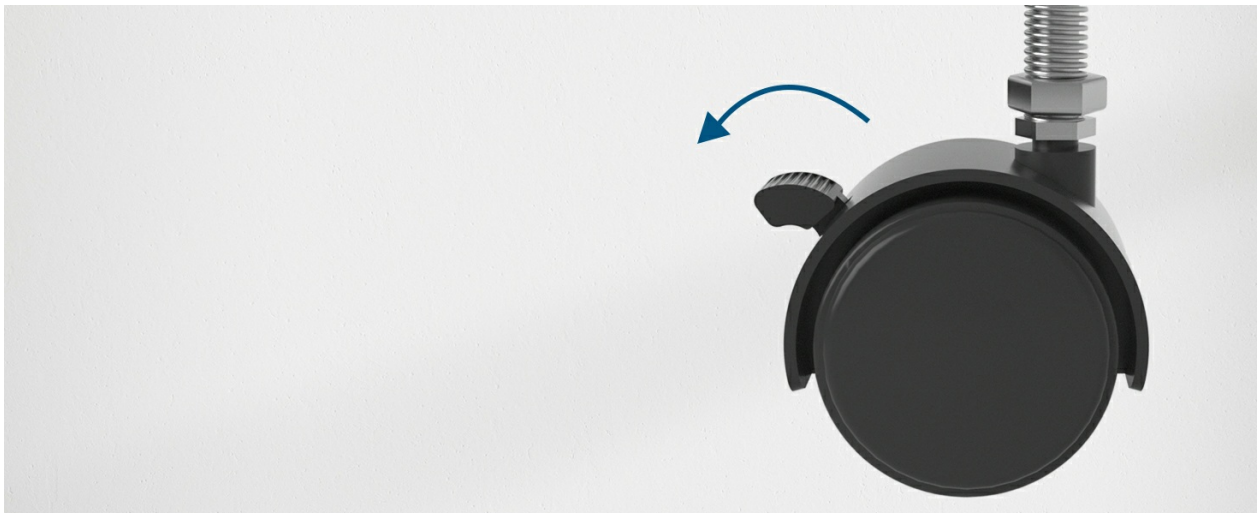

Image: Close-up of a wheel with an integrated locking mechanism.

4.4 Cable Management

Utilize the integrated cable management system to route and conceal your TV and device cables. This helps maintain a tidy appearance and prevents cable clutter.

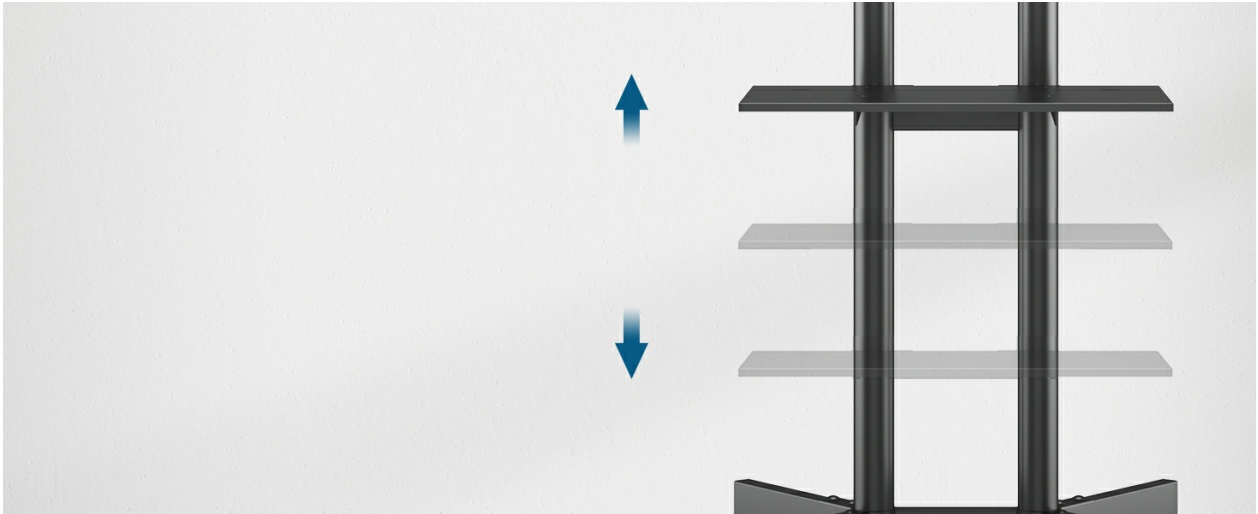

Image: The media shelf attached to the stand, demonstrating cable management.

4.5 Product Demonstration Video

Watch this video for a demonstration of the BONTEC Mobile TV Stand's features and usage:

Your browser does not support the video tag.

Video: BONTEC Mobile TV Stand Display Video. This video showcases the various features and applications of the mobile TV stand in different environments.

5. MAINTENANCE

- **Cleaning:** Use a soft, dry cloth to clean the stand. Avoid abrasive cleaners or solvents that may damage the finish.
- **Inspection:** Periodically check all screws and connections to ensure they remain tight. Re-tighten if necessary.
- **Wheel Care:** Keep the wheels free of dust and debris to ensure smooth movement.

6. TROUBLESHOOTING

| Problem | Possible Cause | Solution |
|------------------------------|--|---|
| Stand is unstable. | Screws are loose; wheels are unlocked. | Check and tighten all assembly screws. Ensure locking wheels are engaged. |
| Difficulty moving the stand. | Wheels are locked; debris in wheels. | Unlock the wheels. Clean any debris from the wheel casters. |
| TV is not level. | Mounting arms are unevenly installed. | Re-check the installation of the TV mounting arms and adjust as needed. |

| Problem | Possible Cause | Solution |
|------------------------------------|---|--|
| Media shelf is not holding weight. | Exceeding weight capacity; loose attachment. | Ensure the weight on the shelf does not exceed 10 kg. Re-tighten shelf attachment screws. |

7. SPECIFICATIONS

| Feature | Detail |
|---------------------------------|--|
| Mounting Type | Floor Mount |
| Movement Type | Tilt |
| Brand | BONTEC |
| Material | Alloy Steel |
| Compatible Devices | TV |
| Maximum Tilt Angle | 15 Degrees |
| Maximum Compatible Size | 85 inches |
| Minimum Compatible Size | 32 inches |
| Max TV Weight Capacity | 60 kg (132 lbs) |
| Max Media Shelf Weight Capacity | 10 kg (22 lbs) |
| VESA Compatibility | 50x50mm to 600x400mm |
| Height Adjustment Range | 1016.5 mm to 1517 mm (8 levels, 71.5 mm steps) |

8. WARRANTY AND SUPPORT

For warranty information or technical support, please refer to the documentation included with your product or visit the official BONTEC website. You can also contact BONTEC customer service through the retailer where you purchased the product.

Contact Information:

- **Brand Store:** [BONTEC Store on Amazon.se](#)
- Refer to your product packaging for specific contact details.