

Fulgor Milano FQSO 4505 MT X

Fulgor Milano FQSO 4505 MT X Compact Steam Oven User Manual

Model: FQSO 4505 MT X

1. IMPORTANT SAFETY INSTRUCTIONS

Read all instructions carefully before using the appliance. Keep this manual for future reference.

- **Electrical Safety:** Ensure the oven is properly grounded. Do not operate with a damaged power cord or plug. Disconnect power before servicing.
- **Burn Hazard:** The oven interior and accessories become very hot during operation. Use oven mitts when handling hot items. Steam is extremely hot; exercise caution when opening the oven door during or after steam cooking.
- **Child Safety:** This appliance is not intended for use by persons (including children) with reduced physical, sensory or mental capabilities, or lack of experience and knowledge, unless they have been given supervision or instruction concerning use of the appliance by a person responsible for their safety. Children should be supervised to ensure that they do not play with the appliance.
- **Cleaning:** Always allow the oven to cool before cleaning. Do not use abrasive cleaners or sharp metal scrapers to clean the oven door glass, as they can scratch the surface, which may result in shattering of the glass.
- **Installation:** Installation must be carried out by a qualified technician in accordance with local regulations. Ensure adequate ventilation.

2. PRODUCT OVERVIEW

The Fulgor Milano FQSO 4505 MT X is a compact steam oven designed for versatile cooking. It features a stainless steel finish, digital controls, and a 34-liter capacity, offering both steam cooking and grill functions.



Image 2.1: The Fulgor Milano FQSO 4505 MT X Compact Steam Oven integrated into kitchen cabinetry.

3. INSTALLATION

Proper installation is crucial for the safe and efficient operation of your oven. It must be installed by a qualified professional.

3.1. Dimensions and Cabinet Requirements

Refer to the diagram below for precise dimensions and minimum clearance requirements for cabinet integration.

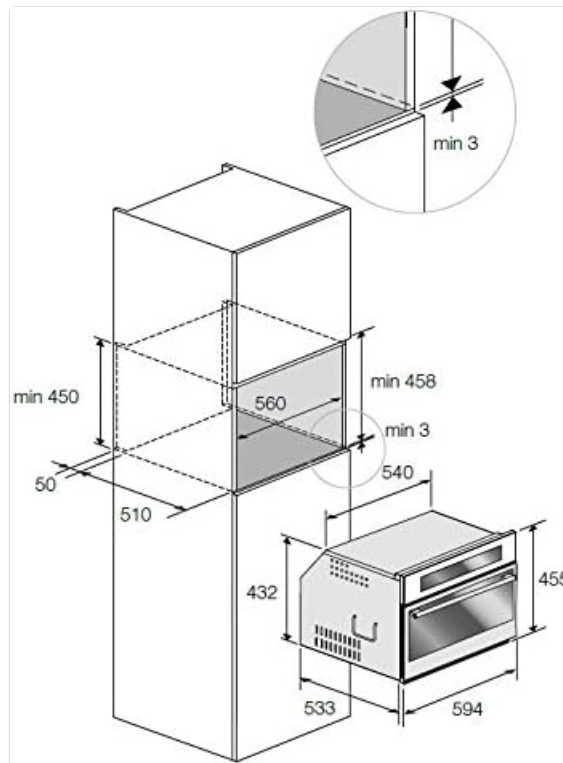

Image 3.1: Dimensional drawing showing the oven's measurements and required cabinet opening for installation.

- **Cut-out Dimensions:** Ensure the cabinet opening matches the specified dimensions (e.g., minimum 450mm height, 560mm width, 540mm depth).
- **Ventilation:** Maintain minimum clearances (e.g., 3mm) around the appliance for proper air circulation and cooling.
- **Electrical Connection:** The oven requires an electrical connection. Ensure the power supply matches the appliance's requirements and is installed by a licensed electrician.

4. OPERATING INSTRUCTIONS

Familiarize yourself with the control panel and cooking functions before first use.

4.1. Control Panel

The oven features a digital control interface combined with metal dials for setting cooking parameters. The digital display shows time, temperature, and selected functions.

4.2. Cooking Modes

- **Steam Cooking:** Ideal for vegetables, fish, and reheating. Fill the water jug before starting. The oven will generate steam for gentle and healthy cooking.
- **Grill:** Use for browning, toasting, or cooking thinner cuts of meat. Position food on the flat grid for best results.

4.3. Setting the Time and Temperature

Use the digital controls and dials to select the desired cooking mode, temperature, and cooking duration. Consult the full manual for specific programming steps for each function.

5. MAINTENANCE AND CLEANING

Regular cleaning and maintenance ensure the longevity and optimal performance of your oven.

5.1. General Cleaning

- **Exterior:** Clean the stainless steel exterior with a soft cloth and a mild, non-abrasive cleaner. Avoid harsh chemicals to prevent damage to the anti-fingerprint finish.
- **Door:** Wipe the oven door with a damp cloth. Do not use abrasive materials on the glass.

5.2. Automatic Descaling

The oven features an automatic descaling function to remove mineral buildup from the steam generator. Follow the on-screen prompts or refer to the detailed manual for instructions on how to initiate and complete the descaling cycle. Use only descaling solutions recommended by Fulgor Milano.

5.3. Cleaning the Cooking Compartment

The stainless steel cooking compartment should be cleaned after each use, especially after steam cooking, to prevent food residue buildup. Use a soft cloth and warm soapy water. For stubborn stains, a specialized stainless steel cleaner can be used.

6. TROUBLESHOOTING

Before contacting customer service, consult the following table for common issues and their solutions.

Problem	Possible Cause	Solution
Oven does not turn on	No power supply; Door not closed properly	Check power connection and circuit breaker; Ensure door is fully closed and door contact switch is engaged.
No steam production	Water jug empty; Descaling required	Fill the water jug; Perform the automatic descaling cycle.
Uneven cooking	Incorrect temperature/time setting; Improper food placement	Adjust settings according to recipe; Ensure food is placed centrally and not overcrowded.
Error code on display	System malfunction	Note the error code and consult the full user manual or contact customer support.

7. TECHNICAL SPECIFICATIONS

Feature	Specification
Brand	Fulgor Milano

Feature	Specification
Model	FQSO 4505 MT X
Type	Compact Steam Oven
Fuel Type	Electric
Capacity	34 Liters
Finish	Stainless Steel (Anti-fingerprint)
Control Type	Digital Control and Metal Dials
Safety Features	Safe Door, Door Contact Switch, Tangential Cooling Ventilation
ASIN	B07DNXXP9F

8. ACCESSORIES

The following accessories are included with your Fulgor Milano FQSO 4505 MT X Compact Steam Oven:

- 1 x Micro-perforated Pot with Stainless Steel Lid
- 1 x Stainless Steel Tray
- 1 x Flat Grid
- 1 x Water Jug
- Connection Cable with Plug

9. WARRANTY AND SUPPORT

Your Fulgor Milano FQSO 4505 MT X Compact Steam Oven comes with a manufacturer's warranty. Please refer to the warranty card included with your product for specific terms and conditions.

For technical assistance, spare parts, or warranty claims, please contact Fulgor Milano customer support. Ensure you have your model number (FQSO 4505 MT X) and purchase date available when contacting support.

Online Resources: Visit the official Fulgor Milano website for additional support, FAQs, and product registration.