

Lx Free PT-1214

Lx Free Power Tower Dip Station Pull Up Bar Instruction Manual

Model: PT-1214

1. SAFETY INFORMATION

- Read the entire instruction manual before assembling and using the product.
- Ensure all bolts and nuts are securely tightened before each use.
- Children should only use this equipment under strict adult supervision.
- Place the power tower on a flat, stable surface. Use a mat underneath to prevent floor damage and enhance stability.
- Do not exceed the maximum weight capacity of 400 lbs.
- Inspect the equipment for any signs of wear, damage, or loose parts before each workout. Discontinue use if any issues are found.
- Consult a physician before starting any new exercise program.

2. PACKAGE CONTENTS

Before assembly, verify that all components are present and undamaged. The package includes:

- Main frame components (heavy-duty steel construction)
- High-density foam rubber handles
- No-slip coated grips and form pads
- Back cushion support
- Assembly tools (wrenches, etc.)
- Instruction manual
- All necessary bolts, nuts, and screws

3. SETUP AND ASSEMBLY

Assembly is required. Please follow these steps carefully. A built-in tool kit is provided.

Step-by-Step Assembly

1. **Assemble the Base:** Attach the two side support frames to the main base crossbars. Ensure the nut holes are aligned before tightening the screws. Use the provided bolts and wrenches.
2. **Attach Vertical Supports:** Secure the main vertical support beams to the assembled base.
3. **Install Dip Station Arms:** Attach the dip station arms, which include the high-density foam pads and grips, to the vertical supports. Ensure they are firmly in place.
4. **Mount Back Cushion:** Install the back cushion support onto the frame. This piece is designed to reduce spinal pressure during exercises.
5. **Assemble Pull-Up Bar:** Attach the multi-grip pull-up bar to the top of the vertical supports.
6. **Final Check:** Once fully assembled, double-check that all bolts and nuts are securely tightened.



Figure 3.1: Detail of the base with non-slip mats and foam handles for stability and comfort.

Four High Degree of Freedom to Adjust

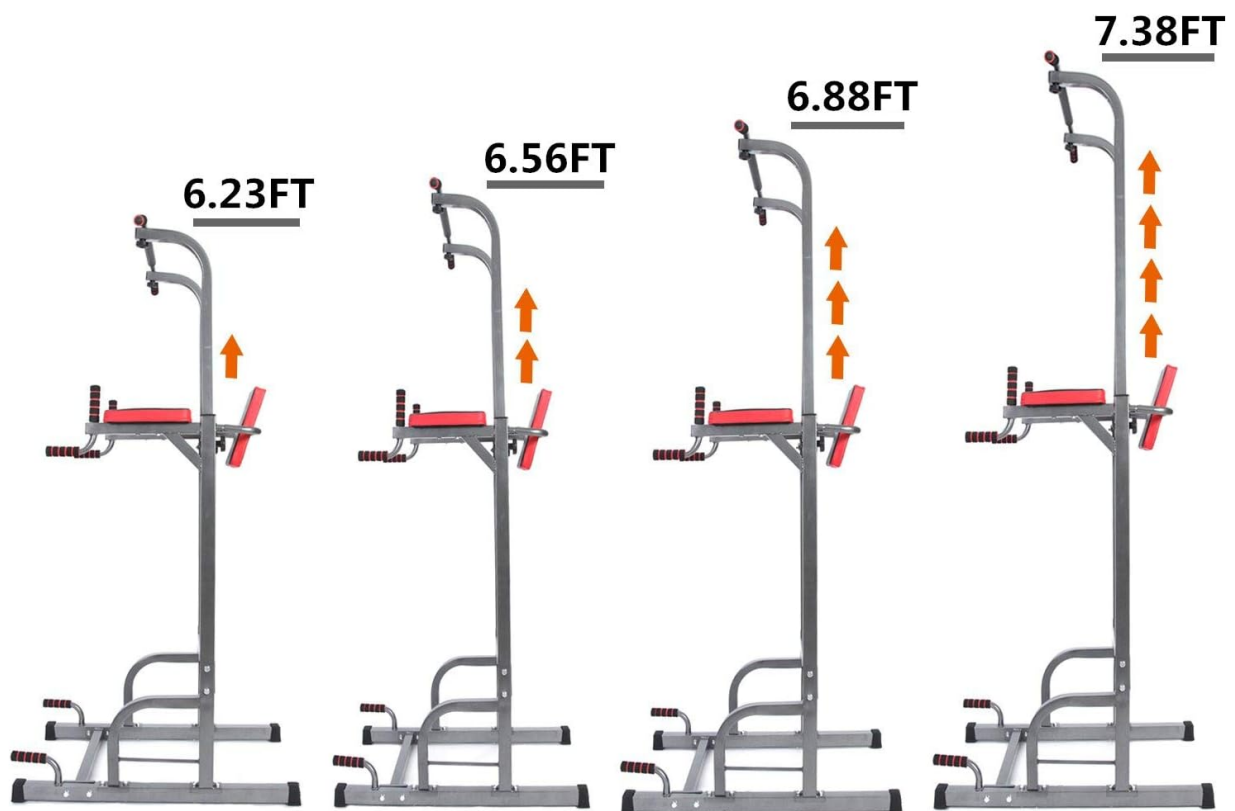

Loosen the safety screw and stretch the horizontal bar to adjust

Figure 3.2: Close-up of the safety screw for height adjustment.



Figure 3.3: The power tower offers multiple height adjustments for various users.

Assembly Video Reference

For visual guidance, refer to the following video demonstrating the assembly process:

Your browser does not support the video tag.

Video 3.1: Assembly demonstration for the Lx Free Power Tower. This video provides a visual walkthrough of the setup process, highlighting key steps and component placement.

4. OPERATION AND EXERCISES

The Lx Free Power Tower is designed for a variety of bodyweight exercises to target different muscle groups.

Adjusting Height

The pull-up tower features 6 adjustable height settings (ranging from 6.5ft to 7.55ft) to accommodate users of different heights. To adjust, loosen the safety screw on the vertical support and slide the upper section to the desired height. Ensure the safety screw is fully tightened after adjustment.

Performing Exercises

- **Pull-ups/Chin-ups:** Use the multi-grip pull-up bar to train arm, back, and shoulder muscles. Vary your grip (wide, narrow, pronated, supinated) to target different areas.
- **Dips:** Utilize the dip station handles to work your chest, triceps, and shoulders.
- **Leg Raises/Knee Raises:** Use the padded armrests and back support for core exercises, targeting abdominal muscles.
- **Push-ups:** The lower handles can be used for elevated push-ups, providing a deeper range of motion and increased challenge.



Figure 4.1: Performing dips on the power tower, engaging chest and triceps.



Figure 4.2: Executing leg raises for core strength using the dedicated station.



Figure 4.3: Performing pull-ups to strengthen back and arm muscles.



Figure 4.4: The lower handles can be used for push-ups, and the tower can assist with stretching.

Product Overview Video

Observe the Lx Free Power Tower in use and its features:

Your browser does not support the video tag.

Video 4.1: A general overview of the Lx Free Power Tower, showcasing its design and various exercise stations.

5. MAINTENANCE

Regular maintenance ensures the longevity and safe operation of your power tower.

- **Cleaning:** Wipe down the frame and pads with a damp cloth after each use to remove sweat and dirt. Avoid abrasive cleaners.
- **Inspection:** Periodically check all structural components, welds, and padding for any signs of wear or damage.
- **Tightening:** Regularly inspect and tighten all bolts and nuts to ensure the equipment remains stable and secure.

6. TROUBLESHOOTING

If you encounter any issues with your power tower, refer to the following table for common problems and solutions.

| Problem | Possible Cause | Solution |
|------------------------------------|--|---|
| Equipment feels unstable or wobbly | Loose bolts or uneven surface. | Ensure all bolts are fully tightened. Place the equipment on a level surface, possibly using a fitness mat. |
| Difficulty adjusting height | Safety screw not fully loosened or mechanism is stiff. | Fully loosen the safety screw. Apply a small amount of silicone lubricant if the mechanism is stiff. |
| Pads or grips show wear | Normal wear and tear from use. | Replace worn pads or grips as needed. Contact customer support for replacement parts. |

7. PRODUCT SPECIFICATIONS

| Feature | Detail |
|--------------------------------|--|
| Brand | Lx Free |
| Model Number | PT-1214 |
| Material | Steel, Foam Rubber |
| Color | Black |
| Product Dimensions (L x W x H) | 38.98" x 22.44" x 74.8" - 90.55" (Adjustable Height) |
| Maximum Weight Recommendation | 400 Pounds |
| Handle Type | Fixed |
| UPC | 748966264783, 748966265155 |

8. WARRANTY AND SUPPORT

The Lx Free Power Tower comes with a limited warranty. For specific warranty details, please refer to the documentation included with your purchase.

Customer Support

If you have any questions, require assistance with assembly, or need to order replacement parts, please contact Lx Free customer support through the retailer where you purchased the product.