

Holdrite QS-5

HoldRite QS-5 Expansion Tank Mounting Bracket User Manual

Model: QS-5

PRODUCT OVERVIEW

The HoldRite QS-5 Quick Strap Expansion Tank Mounting Bracket is engineered to provide secure support for expansion tanks with diameters ranging from 5 inches to 9 inches. This bracket ensures the expansion tank is safely affixed to a wall, effectively reducing the load and stress on the plumbing pipes. Constructed from durable galvanized and stainless steel, the QS-5 bracket offers long-lasting performance and complies with industry plumbing requirements.

SPECIFICATIONS

Material	Galvanized Steel (Bracket), 201/301 Stainless Steel (Straps)
Supported Tank Diameter	5 inches - 9 inches
Supported Tank Capacity	Up to 2.5 gallons
Load Rating	70 lb
Bracket Dimensions (L x W x H)	12 x 0.5 x 1 inches
Strap Length	32.3 inches
Wall Bracket Gauge	16GA
Compliance	UPC/IAPMO and IPC requirements
Item Weight	16 ounces
Model Number	QS-5

Manufacturer	Cash Acme
UPC	671119154115
Origin	Made in USA

COMPONENTS INCLUDED

- 1x HoldRite QS-5 Expansion Tank Mounting Bracket (Wall Bracket)
- 2x Stainless Steel Straps
- 2x Pan Head Screws (for mounting bracket to wall)

Specifications

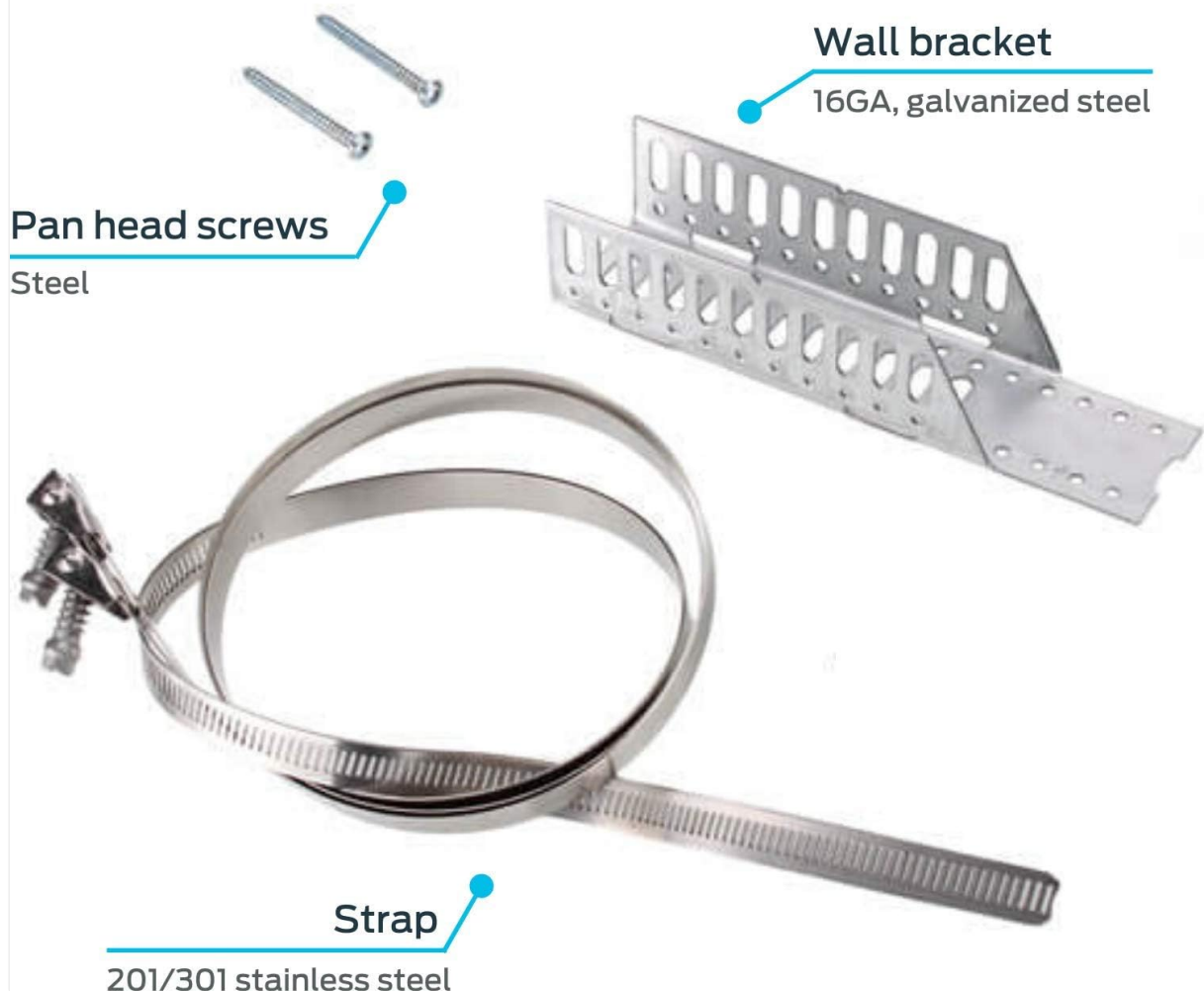

Image: The individual components of the HoldRite QS-5 bracket, including the 16GA galvanized steel wall bracket, two 201/301 stainless steel straps, and two pan head screws for installation.

INSTALLATION INSTRUCTIONS

- 1. Identify Mounting Location:** Choose a sturdy wall stud or appropriate structural support near the expansion tank's intended position. Ensure the location allows for proper connection to the plumbing system and can safely bear the tank's weight.
- 2. Mount the Wall Bracket:** Position the galvanized steel wall bracket against the chosen mounting

surface. Use the provided pan head screws to securely fasten the bracket to the wall. Ensure the bracket is level and firmly attached to support the weight of the expansion tank. The bracket is designed to secure the tank to the wall and offload weight from the pipes.

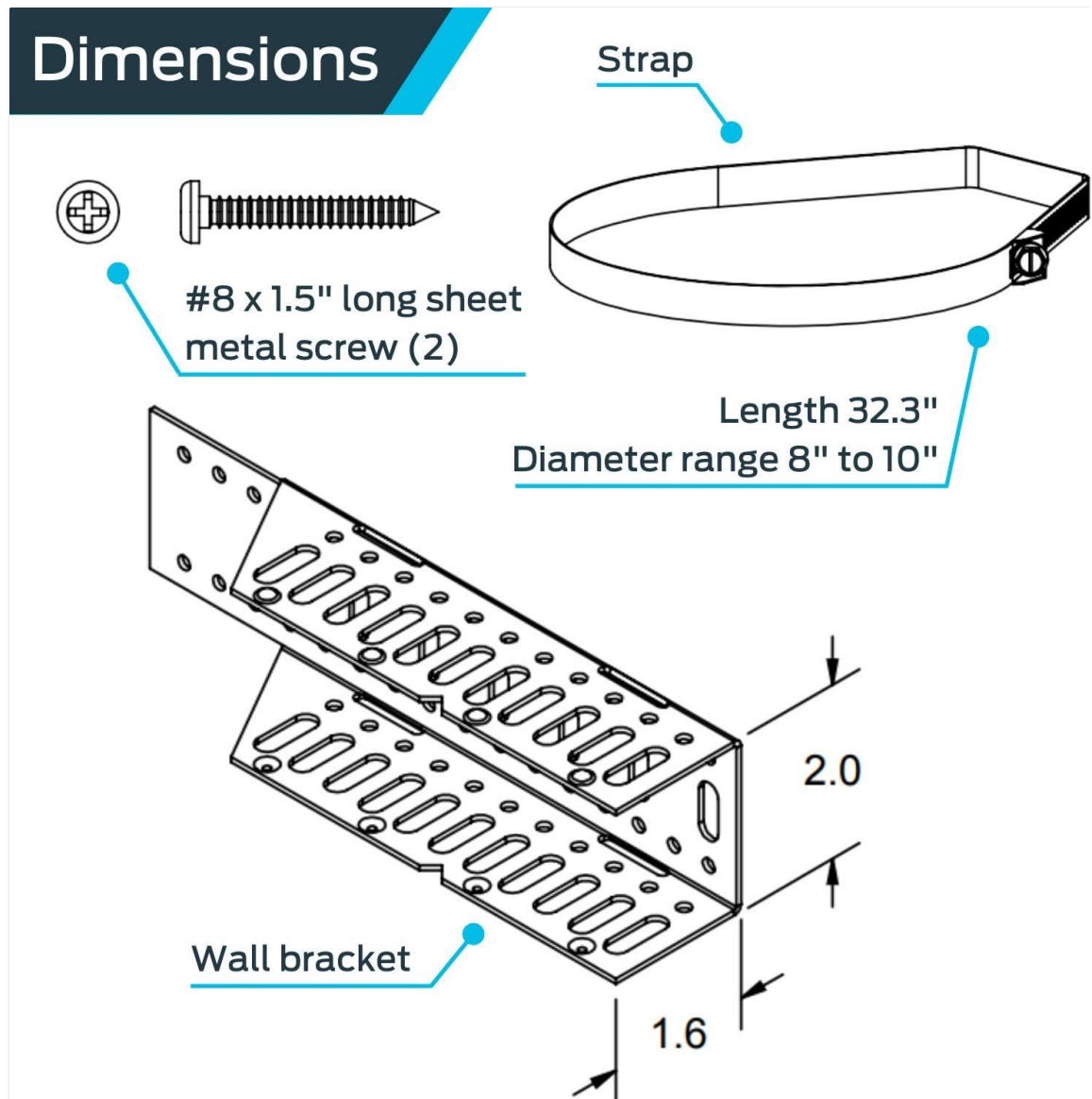

Image: A line diagram illustrating the HoldRite QS-5 bracket installed on a wall, with an expansion tank held securely by the stainless steel straps. This view also shows key dimensions.

- 3. Position the Expansion Tank:** Carefully place the expansion tank onto the mounted wall bracket. The bracket is designed to support tanks with diameters between 5 and 9 inches.
- 4. Secure with Straps:** Wrap the two stainless steel straps around the expansion tank and thread them through the designated slots in the wall bracket. Tighten the clamps on the straps to firmly secure the tank to the bracket. Ensure the tank is snug and stable, preventing any movement. The bracket features a small notch that can align with the welded seam on some tanks, helping to keep the tank plumb.

Specifications

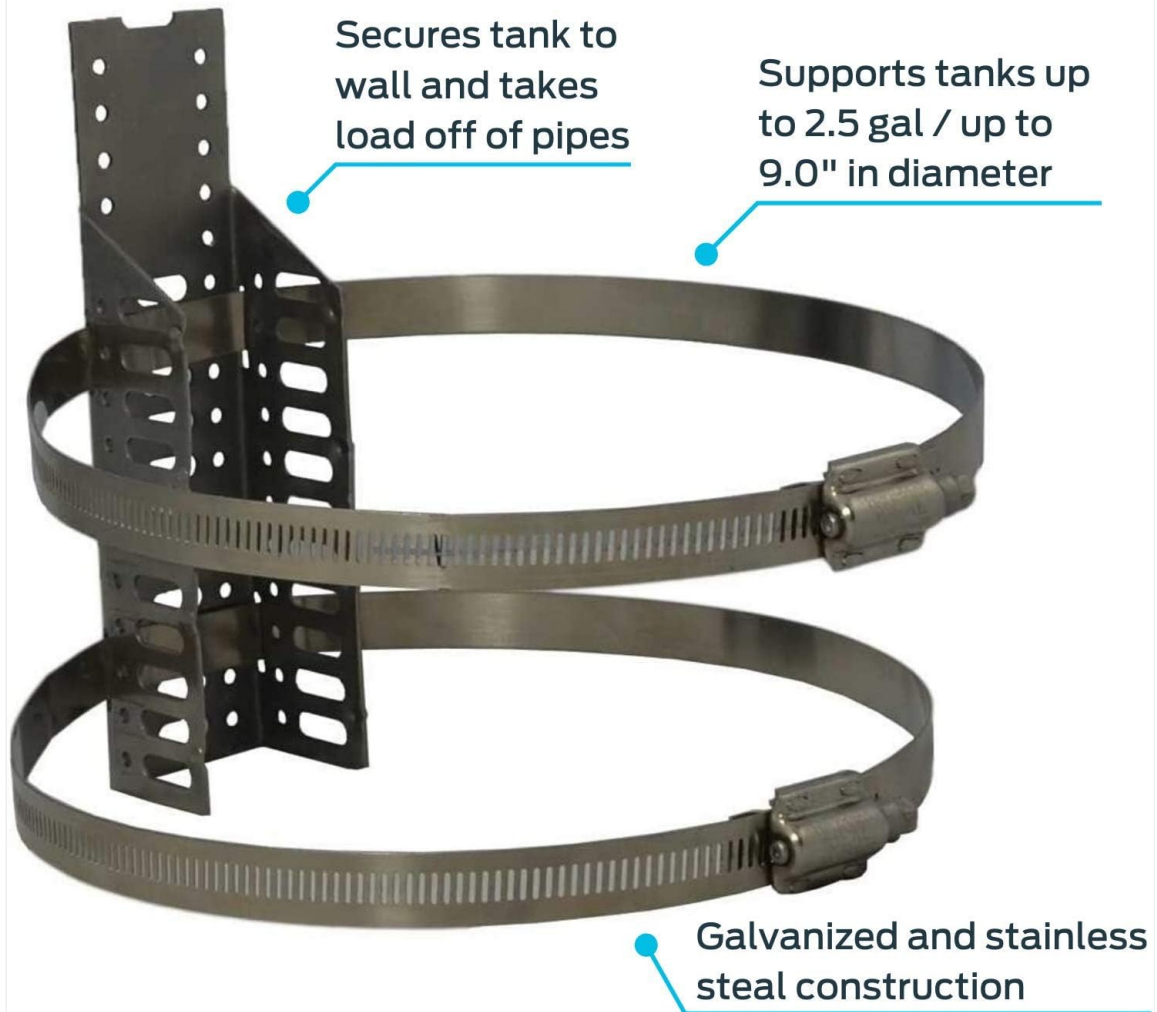

Image: The HoldRite QS-5 bracket with its two stainless steel straps, demonstrating how it secures an expansion tank to a wall. This image highlights the galvanized and stainless steel construction.

- 5. Final Check:** Verify that all connections are tight and the expansion tank is securely mounted. The bracket is rated for a 70 lb load, ensuring reliable support.

MAINTENANCE

The HoldRite QS-5 bracket is constructed from galvanized and stainless steel, providing inherent corrosion resistance and durability. Regular maintenance is minimal. Periodically inspect the bracket and straps for any signs of wear, corrosion, or loosening. Ensure all screws and clamps remain tight to maintain secure support for the expansion tank. Clean with a damp cloth if necessary to remove dust or debris.

TROUBLESHOOTING

Tank Not Securely Held

If the expansion tank does not feel securely held, ensure the straps are properly threaded through the bracket slots and the clamps are tightened sufficiently. It can be helpful to have assistance when tightening the clamps while positioning the tank. Verify that the tank diameter is within the supported range of 5 to 9 inches.

Bracket Appears Loose

Check that the pan head screws fastening the wall bracket to the wall are fully tightened. Ensure the bracket is mounted into a solid structural element, such as a wall stud, to provide adequate support. If the mounting surface is not a stud, appropriate anchors must be used (not included).

WARRANTY AND SUPPORT

For warranty information or technical support regarding your HoldRite QS-5 Expansion Tank Mounting Bracket, please contact HoldRite customer service. Refer to the official HoldRite website or product packaging for the most current contact details and support resources.

[Visit the HoldRite Store on Amazon](#)