



[Manuals.plus](#) /

› [HOTSTART](#) /

› HOTSTART TPS202GT10-000 Coolant Preheater Instruction Manual

HOTSTART TPS202GT10-000

HOTSTART TPS202GT10-000 Coolant Preheater Instruction Manual

Model: TPS202GT10-000

1. INTRODUCTION

This manual provides essential instructions for the safe and effective installation, operation, and maintenance of the HOTSTART TPS202GT10-000 Coolant Preheater. Please read this manual thoroughly before using the product.

The HOTSTART TPS engine preheaters are designed to provide even heat distribution to engine coolant, facilitating reduced engine wear, quicker start-ups, and reduced emissions. This compact unit is suitable for various applications requiring minimal mounting space.

Intended Use: This coolant preheater is designed for pre-heating diesel and gas engines in construction equipment, trucks, marine vessels, and industrial applications. It operates on the thermosiphon principle, eliminating the need for an external pump.



Figure 1: Front view of the HOTSTART TPS202GT10-000 Coolant Preheater. This image shows the main body of the preheater, the power cord with a NEMA 6-15 plug, and the inlet/outlet ports.

2. SAFETY INFORMATION

Always observe the following safety precautions to prevent injury or damage to the equipment:

- **Electrical Safety:** Ensure the power supply matches the heater's voltage (240V) and frequency (60Hz).

Disconnect power before installation or maintenance. Use appropriate circuit protection.

- **Fluid Safety:** Ensure the engine cooling system is properly filled and free of air pockets before operating the heater. Use only approved engine coolants.
- **Hot Surfaces:** The preheater will become hot during operation. Avoid direct contact with the unit while it is powered on or immediately after use.
- **Installation:** Installation should be performed by qualified personnel familiar with engine cooling systems and electrical connections.
- **Mounting:** Securely mount the preheater in a location that allows for proper thermosiphon flow and is protected from physical damage.

3. SPECIFICATIONS

The following are the technical specifications for the HOTSTART TPS202GT10-000 Coolant Preheater:

Feature	Specification
Model Number	TPS202GT10-000
Voltage	240V
Power (kW)	2 kW
Current (Amps)	8.3 Amps
Frequency	60 Hz
Temperature Range (ON)	100°F (38°C)
Temperature Range (OFF)	120°F (49°C)
Engine Displacement	500 – 700 CID (8.2 – 11.5 L)
Heating Element Material	Incoloy 800
Enclosure Rating	IP41
Fluid Capacity	0.11 gal (0.42 L)
Maximum Pressure	90 psi (620 kPa)
Inlet/Outlet Plumbing	0.625" (15.9 mm)
Tank Material	Polyphenylensulfid PPS
Power Cord Length	48" (1219 mm)
Certifications	UL/C-US listed, CE compliant
Package Dimensions	8.11 x 5.35 x 4.49 inches
Item Weight	1.69 pounds

Thermosiphon Heating System

TPS

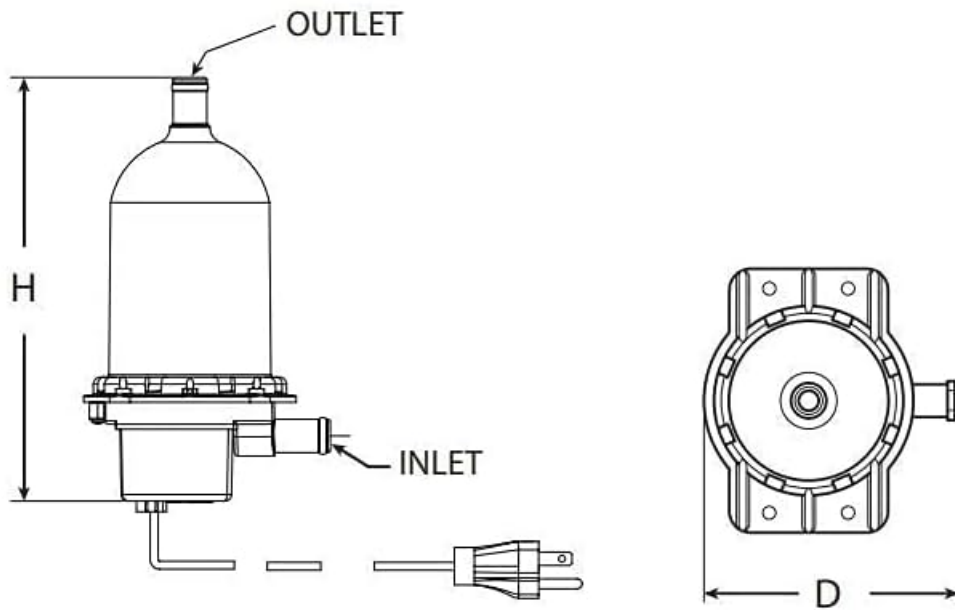

Height (H)	Depth (D)	Weight
7.9"	4.6"	1.7 lbs
200 mm	117 mm	771 g

TPS System	
Phase	single-phase (1 Ø)
Voltage	120V
Ingress	IP41
Tank Material	Polyphenylensulfid PPS
Heating Element Material	Incoloy 800
Min./Max. Ambient Temp.	-4 – 104 °F (-20 – 40 °C)
Certification	UL/C-US listed, CE-compliant

Figure 2: Diagram illustrating the dimensions (Height H, Depth D) and key specifications of the TPS system. This includes details on voltage, ingress protection, tank material, heating element material, ambient temperature range, and certifications.



ORDERING INFORMATION

TPS

Engine Displacement	Power Supply			Heating System		
	V	Ø	Hz	kW	Amps	Model Number
150 CID 2.5 L	120	1	60	0.5	4.2	TPS051GT8-000
	120	1	60	0.5	4.2	TPS051GT10-000
	120	1	60	0.5	4.2	TPS051GT12-000
	240	1	60	0.5	2.1	TPS052GT8-000
	240	1	60	0.5	2.1	TPS052GT10-000
	240	1	60	0.5	2.1	TPS052GT10-013
	240	1	60	0.5	2.1	TPS052GT12-000
350 CID 5.7 L	120	1	60	1	8.4	TPS101GT8-000
	120	1	60	1	8.4	TPS101GT10-000
	120	1	60	1	8.4	TPS101GT12-000
	240	1	60	1	4.2	TPS102GT8-000
	240	1	60	1	4.2	TPS102GT10-000
	240	1	60	1	4.2	TPS102GT10-013
	240	1	60	1	4.2	TPS102GT12-000
350-500 CID 5.7-8.2 L	120	1	60	1.5	12.5	TPS151GT8-000
	120	1	60	1.5	12.5	TPS151GT10-000
	120	1	60	1.5	12.5	TPS151GT12-000
	240	1	60	1.5	6.3	TPS152GT8-000
	240	1	60	1.5	6.3	TPS152GT10-000
	240	1	60	1.5	6.3	TPS152GT10-013
	240	1	60	1.5	6.3	TPS152GT12-000
500-700 CID 8.2-11.5 L	120	1	60	1.8	15	TPS181GT8-000
	120	1	60	1.8	15	TPS181GT10-000
	120	1	60	1.8	15	TPS181GT12-000
	240	1	60	2	8.3	TPS202GT8-000
	240	1	60	2	8.3	TPS202GT10-000
	240	1	60	2	8.3	TPS202GT10-013
	240	1	60	2	8.3	TPS202GT12-000

Power cord length on all models – 48" (1219mm)

TPS engine protectors include a fixed setting thermostat. A single or double digit

TPS engine preheaters include a fixed setting thermostat. A single or double digit numeral at the end of the model number prefix designates the temperature range.

Example: TPS101GT10-000

Figure 3: Ordering information table showing various TPS models, their engine displacement compatibility, power supply details (V, Phase, Hz, kW, Amps), and corresponding model numbers. This table helps in identifying specific model variations.

4. INSTALLATION

Proper installation is crucial for the efficient and safe operation of your HOTSTART preheater. Refer to the diagrams for component identification.

4.1 Mounting Location

- Mount the preheater vertically in a location that allows for natural thermosiphon flow. The inlet should be at a lower point in the cooling system than the outlet.
- Ensure the mounting surface is stable and can support the weight of the unit.
- Allow adequate clearance around the unit for air circulation and maintenance.

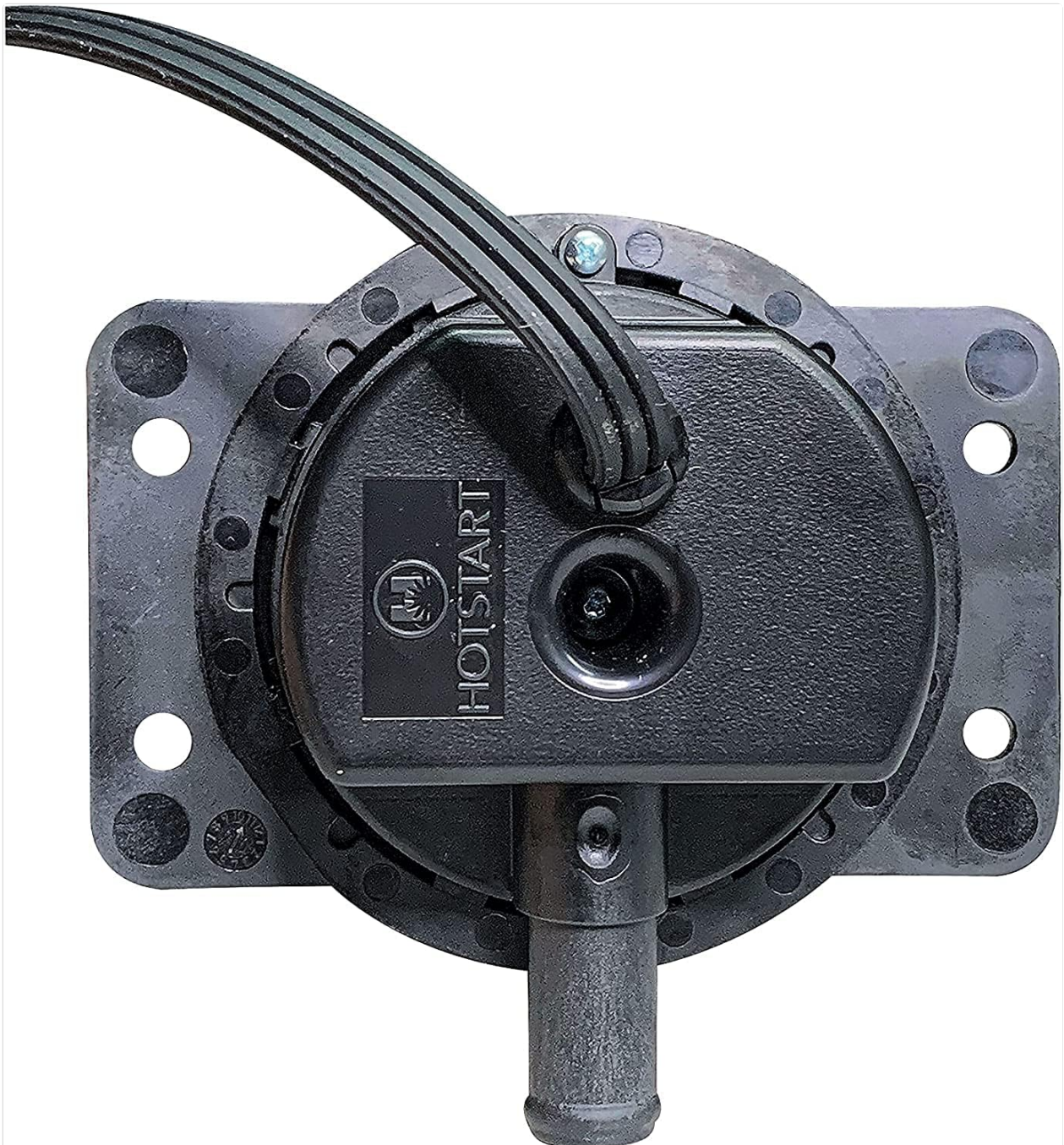

Figure 4: Bottom view of the preheater, showing the mounting plate with multiple holes for secure attachment and the entry point for the power cord.

4.2 Plumbing Connections

- Connect the preheater's inlet (lower port) to a suitable drain or lower point in the engine's cooling system.
- Connect the preheater's outlet (upper port) to a higher point in the engine's cooling system, such as a heater hose return or thermostat housing.
- Use appropriate hoses and clamps for 0.625" (15.9 mm) plumbing connections. Ensure all connections are secure and leak-free.
- After plumbing, fill the cooling system and bleed all air to ensure proper fluid circulation.



Figure 5: Angled view of the preheater, clearly showing the inlet and outlet ports for coolant circulation.

4.3 Electrical Connection

- The unit requires a 240V, 60Hz power supply. It comes with a NEMA 6-15 rated plug.
- Connect the power cord to a dedicated circuit with appropriate overcurrent protection.
- Ensure all electrical connections comply with local codes and regulations.

5. OPERATION

The HOTSTART TPS202GT10-000 Coolant Preheater operates automatically once connected to power and properly installed.

- **Thermosiphon Principle:** The heater warms the coolant, causing it to rise through the outlet. Cooler, denser coolant from the engine then flows into the heater's inlet, creating a continuous circulation without a pump.
- **Automatic Temperature Control:** The preheater features an internal thermostat. It will activate when the coolant temperature drops to 100°F (38°C) and deactivate when it reaches 120°F (49°C), maintaining the engine at an optimal pre-heat temperature.
- Simply plug in the unit to begin the pre-heating cycle. No user intervention is required during operation.

6. MAINTENANCE

Regular maintenance ensures the longevity and optimal performance of your preheater.

- **Visual Inspection:** Periodically inspect the preheater, hoses, and electrical cord for any signs of wear, damage, or leaks.
- **Coolant Level:** Ensure the engine's coolant level is maintained at the manufacturer's recommended level. Low coolant levels can lead to heater malfunction or damage.
- **Coolant Quality:** Use clean, appropriate engine coolant as specified by your engine manufacturer. Contaminated or degraded coolant can reduce heating efficiency and damage the unit.
- **Cleaning:** Keep the exterior of the preheater clean and free from debris. Do not use harsh chemicals or abrasive cleaners.

7. TROUBLESHOOTING

If you encounter issues with your HOTSTART preheater, consider the following common solutions:

- **Heater Not Activating:**
 - Check the power supply and ensure the unit is properly plugged in.
 - Verify that the circuit breaker or fuse has not tripped.
 - Ensure the ambient temperature is below the thermostat's 'ON' setting (100°F / 38°C).
- **Insufficient Heating:**
 - Check the coolant level in the engine. Low coolant can prevent proper circulation.
 - Ensure there are no air pockets in the cooling system.
 - Verify that hoses are not kinked or obstructed, impeding thermosiphon flow.
 - Confirm the unit's specifications (2kW) are appropriate for the engine displacement (500-700 CID).
- **Leaks:**
 - Inspect all hose connections and clamps for tightness.
 - Check the preheater unit itself for any visible cracks or damage.

If troubleshooting steps do not resolve the issue, contact HOTSTART customer support or a qualified service technician.

8. WARRANTY AND SUPPORT

The HOTSTART TPS202GT10-000 Coolant Preheater comes with a **1-Year Warranty** from the date of purchase, covering defects in materials and workmanship under normal use.

For warranty claims, technical assistance, or further support, please contact HOTSTART customer service directly. Keep your proof of purchase for warranty validation.

Manufacturer: HOTSTART



Figure 6: The official HOTSTART company logo.