

[Manuals.plus](#) /

> [Winsome](#) /

> Winsome Piper 3-Shelf Wood Mobile Printer Stand Instruction Manual (Model 94427)

## Winsome Piper 94427

# Winsome Piper 3-Shelf Wood Mobile Printer Stand Instruction Manual

Model: 94427

## INTRODUCTION

---

This manual provides detailed instructions for the assembly, operation, and maintenance of your Winsome Piper 3-Shelf Wood Mobile Printer Stand, Model 94427. Please read all instructions carefully before beginning assembly and retain this manual for future reference.



Image: The Winsome Piper 3-Shelf Wood Mobile Printer Stand in a home office setting, featuring a printer on the top surface, a laptop on the pull-out tray, and paper in the open shelf.

## SAFETY INFORMATION

---

Always follow these safety guidelines to prevent injury or damage to the product:

- Ensure all parts are securely fastened before use.
- Do not exceed the maximum weight recommendations for each shelf and the top surface.
- Keep small parts away from children during assembly.
- Assemble on a soft, clean surface to prevent scratching the furniture.
- Periodically check all connections to ensure they remain tight.
- Use caution when moving the stand, especially on uneven surfaces.

## PACKAGE CONTENTS

---

Verify that all components are present before beginning assembly. Refer to the assembly diagram for part identification.

- Wood panels and shelves

- Drawer components and filing rods
- Pull-out tray mechanism
- Casters (wheels)
- Assembly hardware (screws, bolts, etc.)
- Allen Key
- Instruction manual

## SETUP AND ASSEMBLY

Assembly is required for this product. It is recommended to have a Phillips head screwdriver in addition to the provided Allen key. Follow the step-by-step instructions provided in the included assembly guide. It is advisable to lay out all parts and identify them before starting.

### Recommended Tools:

- Allen Key (provided)
- Phillips Head Screwdriver (not provided)

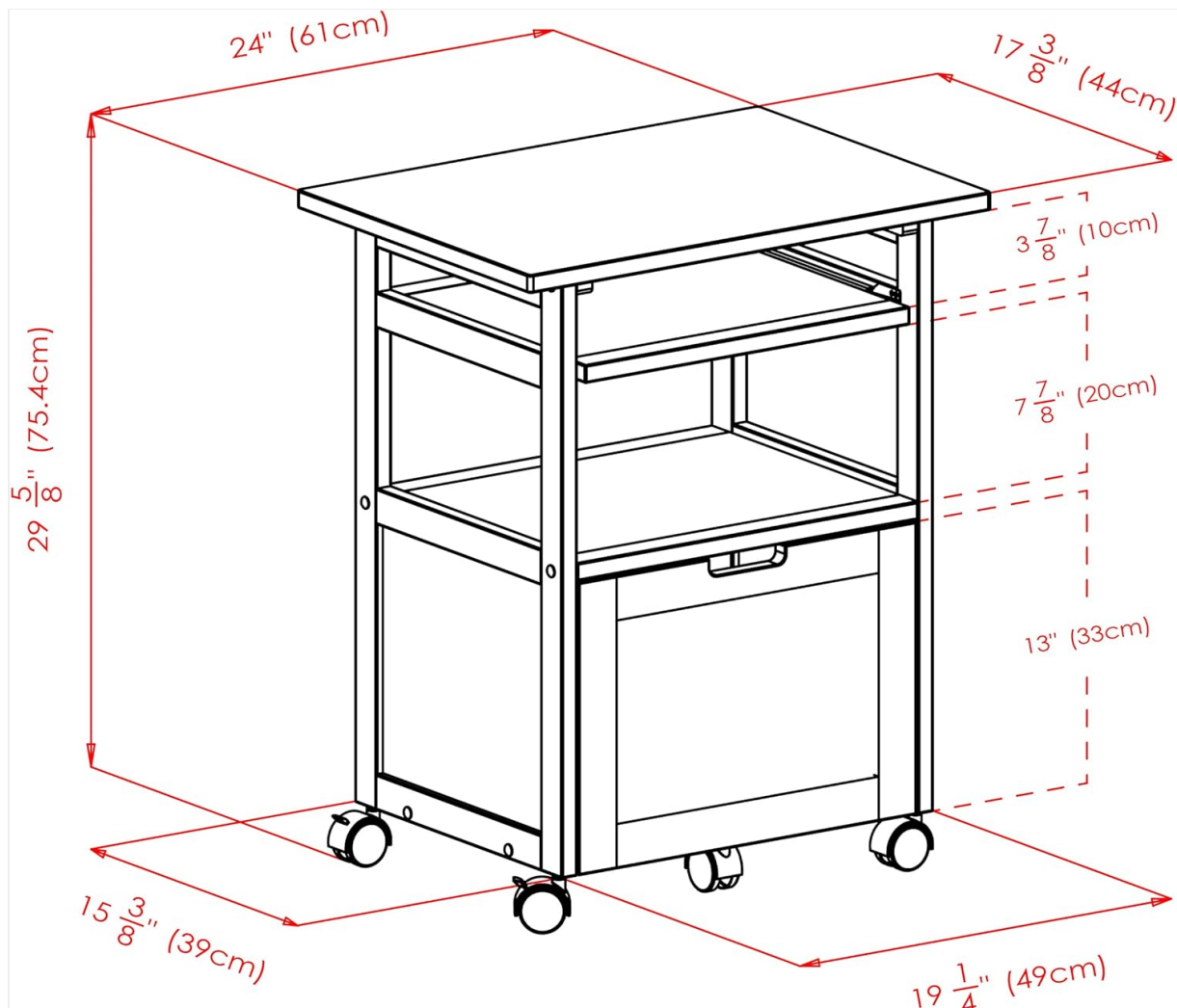

Image: Technical diagram showing the dimensions of the Winsome Piper Printer Stand, including height, width, and depth, as well as internal shelf and drawer clearances.

### Assembly Tips:

- Identify all parts before assembly. Some parts may look similar.
- Do not fully tighten all screws until the unit is mostly assembled to allow for minor adjustments.
- Ensure the drawer slides are correctly oriented for smooth operation.

- Attach casters last, ensuring they are securely fastened.

## OPERATING INSTRUCTIONS

---

### Using the Printer Stand:

- **Top Surface:** Designed to hold a printer or other office equipment. Maximum weight capacity: 50 lbs (23 kg).
- **Pull-out Tray:** Use for a laptop, keyboard, or frequently accessed office supplies. Dimensions: 16.9"W x 15.4"D with a clearance of 4"H. Maximum weight capacity: 15 lbs (7 kg).
- **Middle Shelf:** Suitable for paper reams, books, or other storage. Dimensions: 17.8"W x 15.4"D with a clearance of 7.9"H. Maximum weight capacity: 35 lbs (16 kg).
- **Bottom Pull-out Drawer:** Functions as a filing cabinet for letter-size folders or general storage. Dimensions: 16"W x 13"D x 11"H. Features an extra caster for support when extended. Maximum weight capacity: 25 lbs (11 kg).
- **Mobility:** The four swivel casters allow for easy movement and positioning. Lock two casters to secure the stand in place.



Image: The Winsome Piper Printer Stand with a laptop placed on its extended pull-out tray, demonstrating its use as a workstation.



Image: The Winsome Piper Printer Stand with its bottom drawer open, revealing hanging file folders for organized document storage.

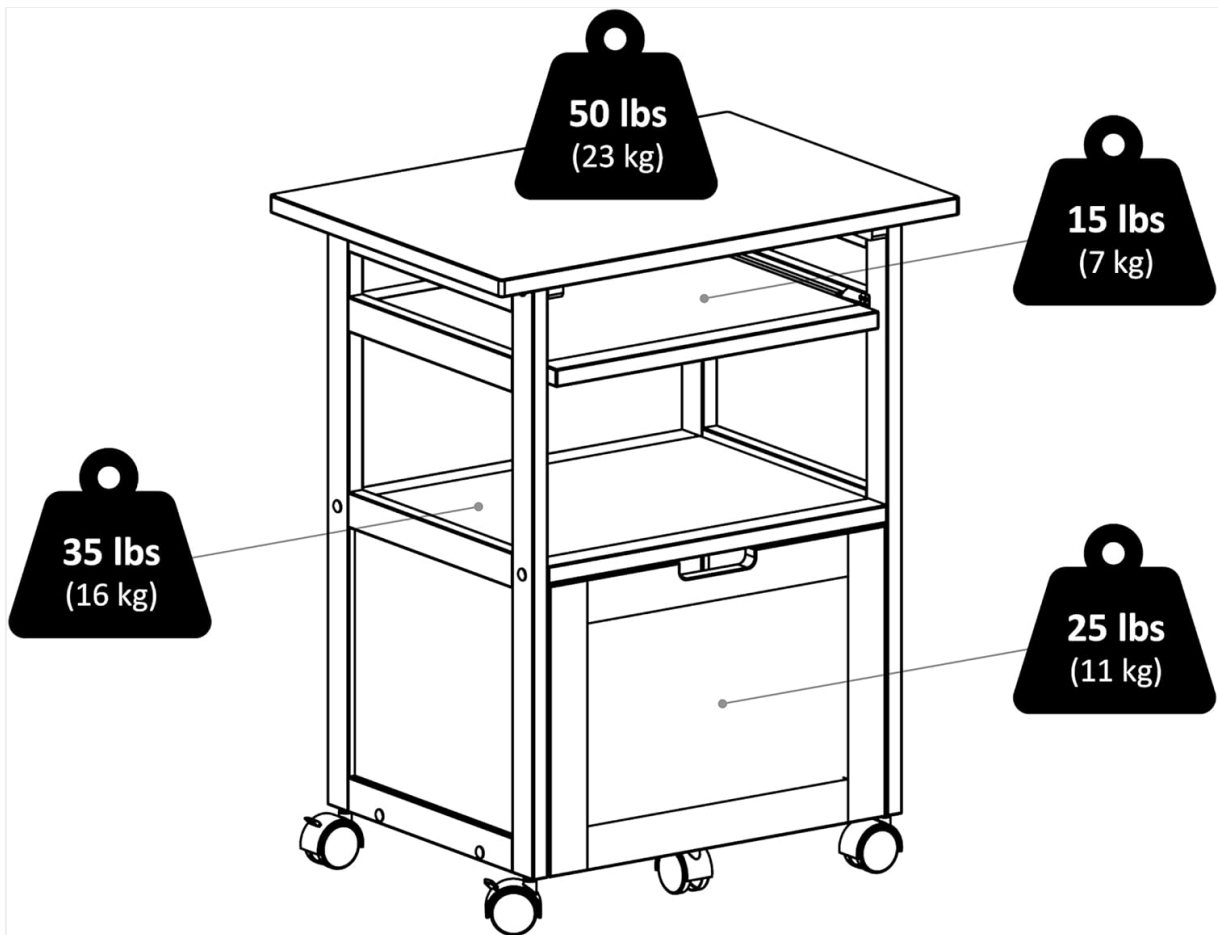

Image: A diagram of the Winsome Piper Printer Stand illustrating the maximum weight capacities for the top surface (50 lbs), pull-out tray (15 lbs), middle shelf (35 lbs), and bottom drawer (25 lbs).

## MAINTENANCE AND CARE

To ensure the longevity and appearance of your printer stand:

- **Cleaning:** Wipe surfaces with a damp cloth. Avoid harsh chemicals or abrasive cleaners, as these can damage the walnut finish.
- **Dusting:** Regularly dust with a soft, dry cloth.
- **Hardware:** Periodically check and tighten all screws and bolts to maintain structural integrity.
- **Spills:** Clean spills immediately to prevent staining.

## TROUBLESHOOTING

Problem	Possible Cause	Solution
Drawer does not slide smoothly.	Misaligned drawer slides or uneven assembly.	Check that drawer slides are installed correctly and lubricate if necessary. Loosen assembly screws slightly, adjust drawer, then retighten.
Stand is wobbly.	Loose hardware or uneven floor.	Tighten all assembly screws. Ensure casters are fully engaged. Move to a level surface or use shims if necessary.
Missing parts.	Packaging error.	Contact Winsome customer support for assistance.

## SPECIFICATIONS

<b>Brand:</b>	Winsome
<b>Model Name:</b>	Piper
<b>Model Number:</b>	94427
<b>Product Dimensions (D x W x H):</b>	24.02" x 27.75" x 29.65" (61cm x 70.5cm x 75.3cm)
<b>Item Weight:</b>	37 Pounds (16.8 kg)
<b>Maximum Weight Recommendation (Top):</b>	50 Pounds (23 kg)
<b>Maximum Weight Recommendation (Pull-out Tray):</b>	15 Pounds (7 kg)
<b>Maximum Weight Recommendation (Middle Shelf):</b>	35 Pounds (16 kg)
<b>Maximum Weight Recommendation (Bottom Drawer):</b>	25 Pounds (11 kg)
<b>Frame Material:</b>	Wood (Solid and Composite)
<b>Color:</b>	Walnut
<b>Number of Shelves:</b>	2 (plus pull-out tray)
<b>Number of Drawers:</b>	1 (filing drawer)
<b>Assembly Required:</b>	Yes
<b>UPC:</b>	021713944276

## WARRANTY AND SUPPORT

For warranty information or assistance with missing/damaged parts, please contact the manufacturer directly. Refer to the contact information provided in your original packaging or visit the official Winsome website.

**Manufacturer Warranty Description:** Contact manufacturer.

For additional support or product inquiries, you may visit the [Winsome Store on Amazon](#).