



Manuals.plus /

› Eightwood /

› Eightwood SMA Male Crimp RF Connector EWSMA009-10 Instruction Manual

## Eightwood EWSMA009-10

# Eightwood SMA Male Crimp RF Connector Instruction Manual

Model: EWSMA009-10

Brand: Eightwood

## INTRODUCTION

---

This manual provides instructions for the proper assembly and use of the Eightwood 10-piece SMA Male Crimp RF Connector set. These connectors are designed for reliable signal connection in various RF applications.

## PACKAGE CONTENTS

---

Verify that all components are present before beginning assembly.

- 10 x SMA Male Crimp RF Connectors
- 10 x Inner Pins
- 10 x Crimp Tubes
- 10 x Heat Shrink Tubes



Image: A set of SMA Male Crimp RF Connectors, including the main connector body, inner pins, crimp tubes, and heat shrink tubes.

## FEATURES

- **Connector Type:** SMA Male (inside threads with male inner pin)
- **Termination:** Cable-crimp
- **Impedance:** 50 ohms
- **Material:** Gold-plated brass for durability and signal integrity

## COMPATIBILITY

These SMA Male Crimp RF Connectors are compatible with the following coaxial cable types:

- RG-174
- RG-316
- RG-188

- RG-188A
- LMR-100

## INSTALLATION INSTRUCTIONS

Follow these steps to properly assemble the SMA Male Crimp RF Connector onto your coaxial cable. A crimping tool and soldering iron are required.

### 1. Prepare the Cable

1. Cut the coaxial cable to the desired length. Ensure a clean, straight cut.
2. Slide one heat shrink tube and one crimp tube onto the cable. Ensure they are oriented correctly and pushed far enough back to not interfere with stripping.
3. Strip the cable jacket, shield, dielectric, and inner conductor according to the recommended dimensions for SMA connectors and your specific cable type (e.g., RG316). Refer to the diagram below for typical strip lengths.

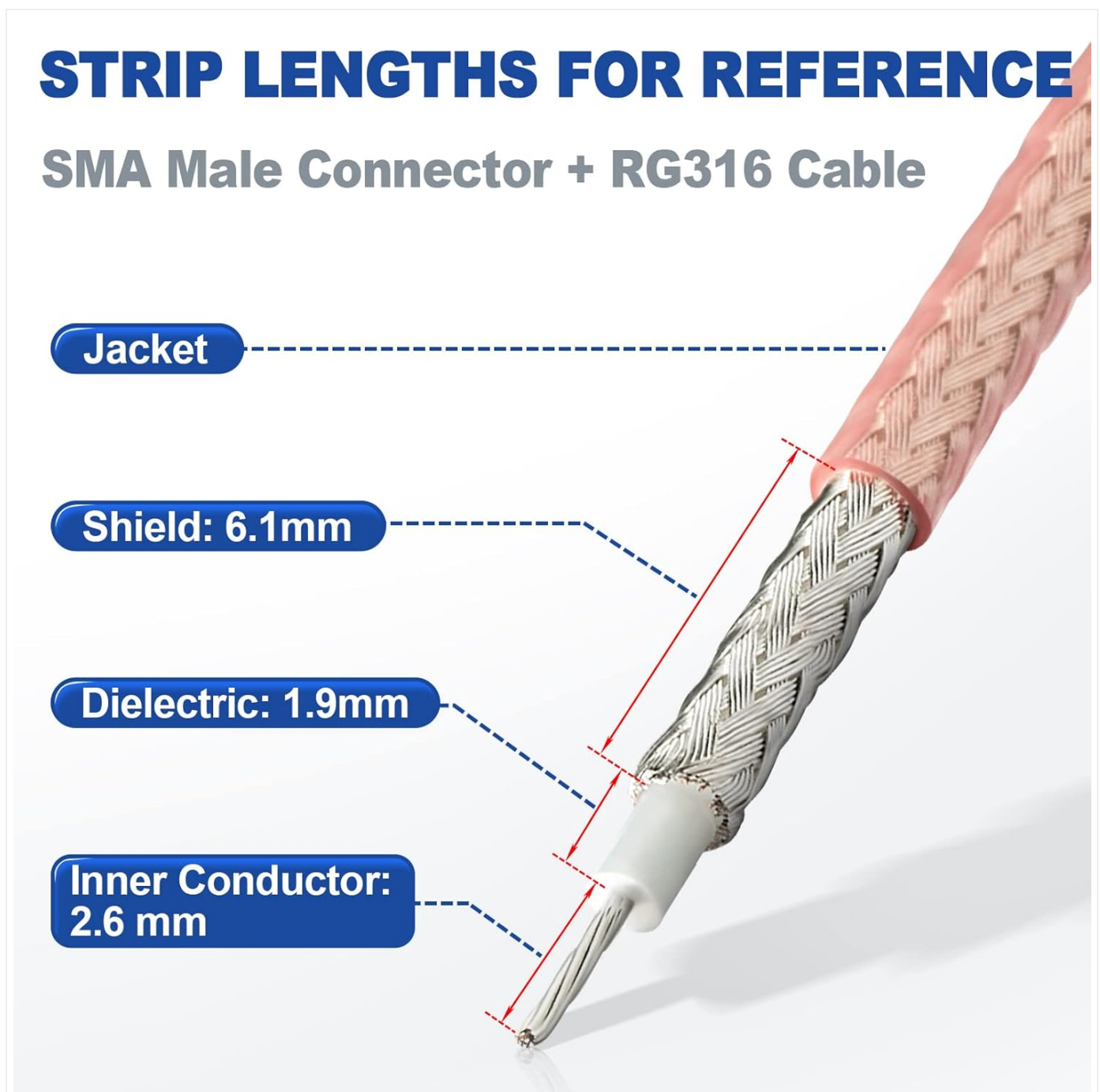

Image: Diagram showing recommended strip lengths for the cable jacket, shield, dielectric, and inner conductor for an SMA Male Connector

with RG316 cable. Jacket: 6.1mm, Shield: 6.1mm, Dielectric: 1.9mm, Inner Conductor: 2.6mm.

## 2. Solder the Inner Pin

4. Carefully insert the stripped inner conductor of the cable into the inner pin.
5. Solder the inner conductor to the inner pin. Ensure a strong, clean solder joint without excess solder that could cause a short circuit.



Image: Close-up view of the SMA Male Crimp RF Connector's inner pin and crimp tube, showing the components before assembly.

## 3. Assemble the Connector Body

6. Insert the soldered inner pin and cable into the main connector body. The inner pin should seat firmly into the dielectric of the connector.
7. Ensure the cable's braided shield is evenly distributed around the connector's rear barrel.



Image: Disassembled view of an Eightwood SMA Male Crimp RF Connector, showing the main body, inner pin, and crimp tube.

#### **4. Crimp the Connector**

8. Slide the crimp tube forward over the braided shield and the rear barrel of the connector.
9. Using an appropriate crimping tool, crimp the tube firmly onto the connector and cable shield. This secures the shield and provides strain relief.

#### **5. Apply Heat Shrink**

10. Slide the heat shrink tube over the crimped area.
11. Apply heat evenly with a heat gun until the tube shrinks tightly around the connector and cable, providing additional strain relief and environmental protection.

# Heat Shrink Tubes



Image: A collection of black heat shrink tubes, used for insulating and protecting cable connections.

## Installation Video Guide



Video: An official Eightwood video demonstrating the assembly process for SMA Male Crimp Connectors with RG316/RG174 cable. This video provides a visual guide to the installation steps.

## OPERATING THE CONNECTOR

---

Once properly assembled, the SMA Male Crimp RF Connector is ready for use. Connect it to a compatible SMA Female port by aligning the threads and gently screwing it on until finger-tight. Avoid overtightening to prevent damage to the connector or the mating port.

## MAINTENANCE

---

- Keep connectors clean and free from dust or debris. Use a lint-free cloth if cleaning is necessary.

- Inspect connectors periodically for any signs of damage, corrosion, or loose connections.
- Store unused connectors in a dry, protected environment to prevent oxidation.

## TROUBLESHOOTING

---

- **Poor Signal / Intermittent Connection:**
  - Check the solder joint on the inner pin for continuity and proper connection.
  - Ensure the crimp tube is securely fastened, making good contact with the cable shield.
  - Verify that the cable stripping dimensions were accurate, preventing shorts or open circuits.
  - Inspect the mating SMA female port for damage or debris.
- **Connector Not Fitting:**
  - Confirm that you are using an SMA Male connector with an SMA Female port.
  - Check for any bent inner pins or damaged threads on either connector.

## SPECIFICATIONS

<b>Brand</b>	Eightwood
<b>Model Number</b>	EWSMA009-10
<b>Connector Type</b>	RF Connector (SMA Male)
<b>Cable Type</b>	Coaxial (RG-174, RG-316, RG-188, RG-188A, LMR-100 compatible)
<b>Impedance</b>	50 Ohms
<b>Material</b>	Gold-plated Brass
<b>Unit Count</b>	10 Count
<b>Product Dimensions</b>	1.18 x 0.39 x 0.39 inches (approximate, per connector)
<b>Item Weight</b>	1.06 ounces (total for 10 pcs)

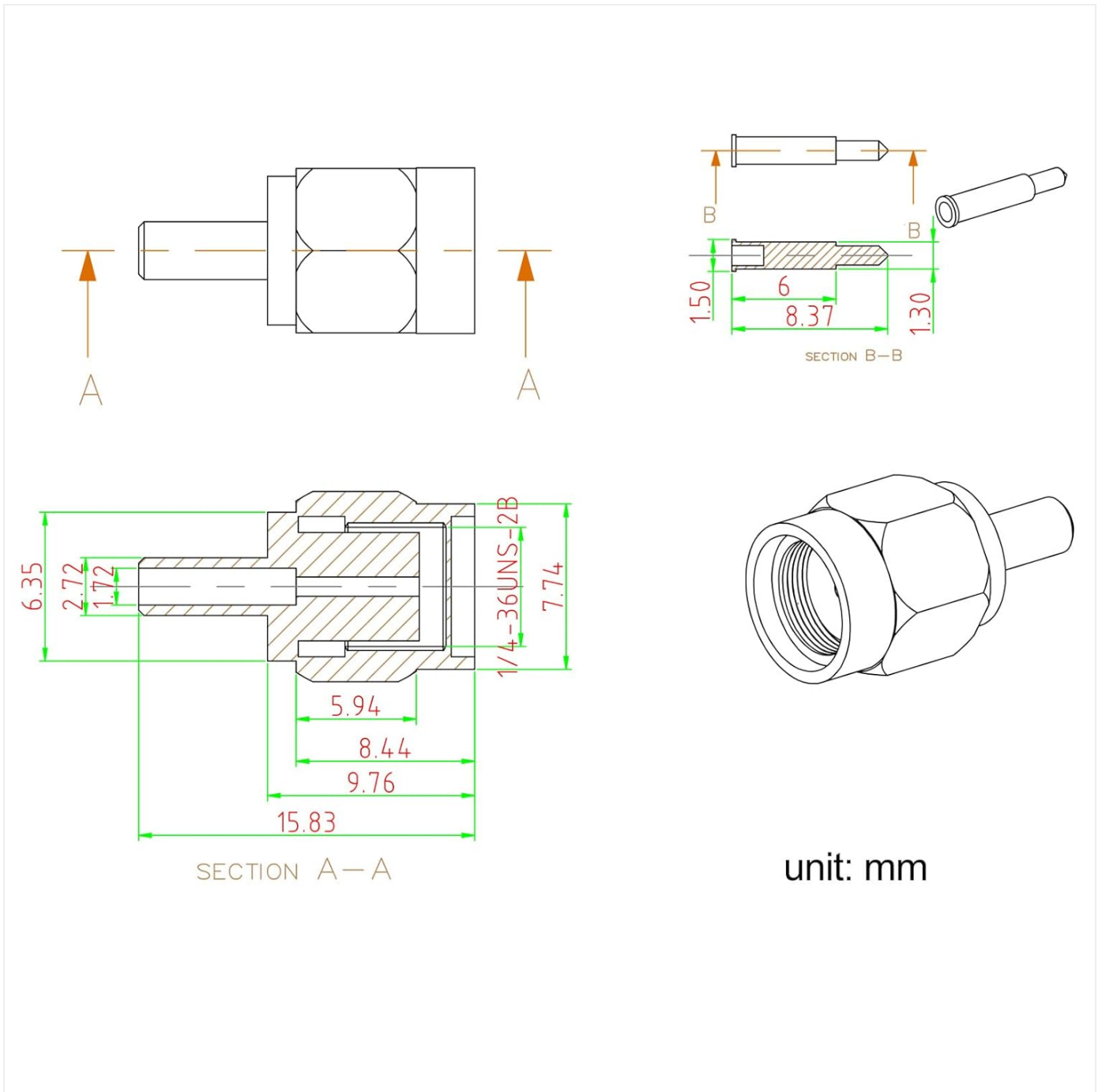

Image: Technical drawing illustrating the dimensions of the SMA Male Crimp RF Connector in millimeters.

## WARRANTY AND SUPPORT

For warranty information or technical support regarding your Eightwood SMA Male Crimp RF Connectors, please refer to the manufacturer's official website or contact their customer service directly. Product authenticity can be verified via the unique code on each item.

