

[Manuals.plus](#) /

> [Gikfun](#) /

> Gikfun 6x6x4.3mm TACT Switch Push Button User Manual EK1019

Gikfun EK1019

Gikfun 6x6x4.3mm TACT Switch Push Button User Manual EK1019

1. INTRODUCTION

This manual provides essential information for the Gikfun 6x6x4.3mm TACT Switch Push Button, model EK1019. These momentary switches are designed for use in various electronic projects, including Arduino and custom PCB applications. Each pack contains 50 pieces, offering a reliable solution for your prototyping and development needs.

SIZE

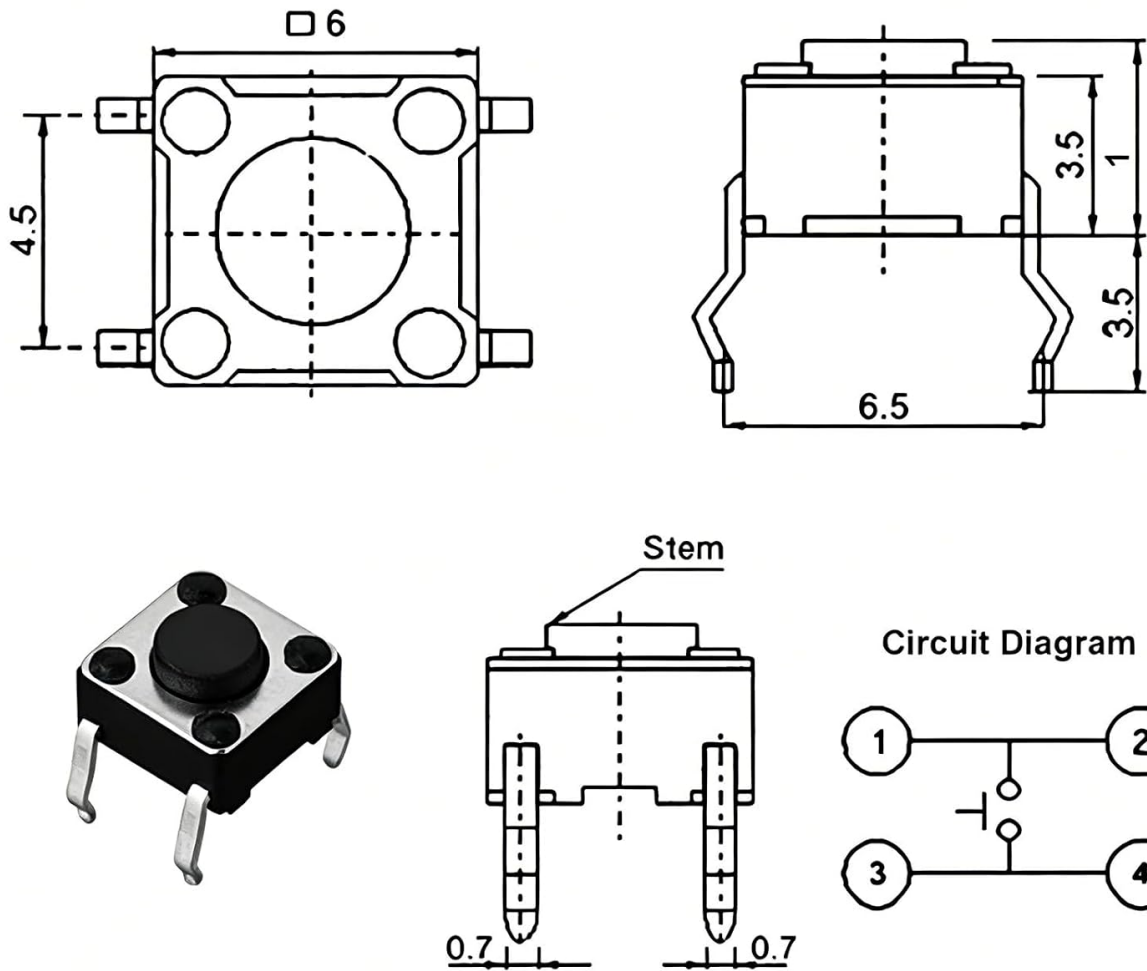

Image: Two Gikfun 6x6x4.3mm TACT switches, showing their compact design.

Key Features:

- **Compact Size:** Small volume for space-constrained designs.
- **High Sensitivity:** Responsive tactile feedback upon actuation.
- **Dust-Proof Design:** Enhanced durability in various environments.
- **Long Lasting:** Rated for 100,000 operations.
- **Good Electrical Conductivity:** Ensures reliable signal transmission.
- **Wear-Resistant and Durable:** Constructed for extended operational life.

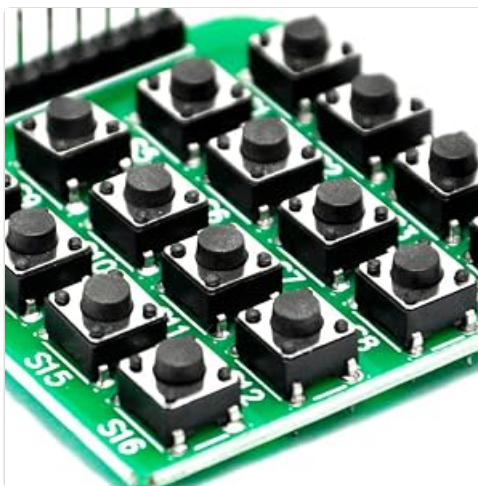

Image: Visual representation of the TACT switch's key features.

2. SPECIFICATIONS

The following table details the technical specifications for the Gikfun 6x6x4.3mm TACT Switch Push Button.

Specification	Value
Operation Mode	Push Button (Momentary)
Current Rating	50 mA
Operating Voltage	12 V
Contact Type	Normally Open
Connector Type	Through Hole
Switch Type	Push Button
Material	Plastic (Body), Copper (Contact)
Circuit Type	1-way
Mounting Type	PCB Mount
Actuator Type	Push Button
Number of Positions	2
Control Method	Touch
Life Expectancy	100,000 times
International Protection Rating	IP54
Certifications	CE, RoHS, UL
Dimensions (approx.)	6x6x4.3mm



Image: Technical drawing with dimensions and circuit diagram of the TACT switch.

3. SETUP AND INSTALLATION

The Gikfun TACT switches are designed for through-hole mounting on Printed Circuit Boards (PCBs) or for use with breadboards in prototyping. Ensure proper orientation and secure connection for optimal performance.

3.1 PCB Mounting

Insert the four pins of the TACT switch into the corresponding holes on your PCB. Solder each pin securely to establish electrical and mechanical connections. The switch is typically mounted with the button facing upwards for easy access.



Image: TACT switch mounted on a red PCB.

3.2 Breadboard Usage

For prototyping, the switch pins can be inserted directly into a standard breadboard. Ensure all four pins make good contact with the breadboard's internal connections. The pins are spaced to fit common breadboard layouts.



Place your idea here
Turn great idea into reality

Gikfun Inc focus on electronic design, development and marketing of Arduino.
We'd like to receive your valuable suggestions for our products and make your idea come true.

Image: TACT switches being used in an Arduino and breadboard setup.

4. OPERATING INSTRUCTIONS

The Gikfun TACT switch is a momentary push button. This means it completes a circuit only while the button is being pressed. Once released, the circuit returns to its open state.

4.1 Basic Operation

1. **Press:** Apply gentle pressure to the top of the button. This action closes the internal circuit, allowing current to flow.
2. **Release:** Remove pressure from the button. The internal spring mechanism will return the button to its original position, opening the circuit.

These switches are commonly used for input signals in microcontrollers (like Arduino), resetting devices, or as control buttons in various electronic gadgets.

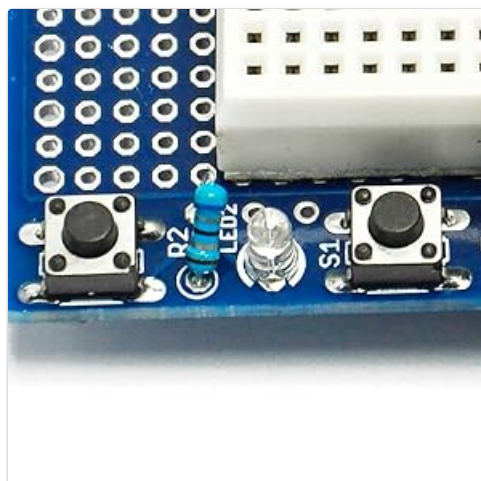

Image: Common applications for TACT switches.

5. MAINTENANCE

Gikfun TACT switches are designed for durability and require minimal maintenance. Follow these guidelines to ensure long-term performance:

- **Cleaning:** If dust or debris accumulates around the button, gently clean with a soft, dry brush or compressed air. Avoid using liquid cleaners directly on the switch.
- **Handling:** Avoid applying excessive force or impact to the button, as this can damage the internal mechanism.
- **Storage:** Store unused switches in a dry, cool environment, away from direct sunlight and corrosive substances.

6. TROUBLESHOOTING

If you encounter issues with your TACT switch, consider the following troubleshooting steps:

- **Switch Not Responding:**
 - Verify that the switch pins are correctly inserted and making good contact with the breadboard or PCB.
 - Check solder joints on PCBs for cold joints or bridges.
 - Ensure the circuit is properly wired and receiving power.
 - Test with a multimeter to confirm continuity when pressed and open circuit when released.
- **Intermittent Operation:**
 - This may indicate a loose connection or a faulty switch. Re-check connections or replace the switch.
 - Ensure the button is fully depressing and returning to its original position without obstruction.
- **Physical Damage:**
 - Inspect the switch for any visible cracks, bent pins, or deformation. Replace damaged switches.

7. PRODUCT VIDEO

Watch the official product video for a visual overview of the Gikfun TACT Switch Push Button.

Your browser does not support the video tag.

Video: An official Gikfun video demonstrating the 6x6x4.3mm TACT Switch Push Button, showing its physical characteristics and potential uses.