

WENKO 20886100

WENKO Vacuum-Loc 2-Tier Wall Shelf with 2 Hooks, Chrome - Instruction Manual

1. PRODUCT OVERVIEW

The WENKO Vacuum-Loc 2-Tier Wall Shelf provides a stable and high-quality storage solution for your bathroom or kitchen. It features two baskets for organizing cosmetics or other items and two additional hooks for hanging towels or accessories. This innovative system allows for quick and reliable installation on all air-impermeable and slightly irregular surfaces without the need for drilling or screwing.

Key Features:

- Vacuum-Loc system for drill-free installation.
- Extremely strong hold, supporting up to 33 kg per lock.
- Repositionable as often as required and removable without leaving residue.
- Made from chrome-plated steel for durability and a sleek finish.
- Two storage tiers and two integrated hooks for versatile organization.

2. SAFETY WARNINGS

Always ensure the shelf is securely fixed to the wall before placing items on it. Do not overload the shelf beyond its maximum weight limit of 33 kg to prevent accidents or damage.

3. SETUP AND INSTALLATION

The WENKO Vacuum-Loc system offers a simple and secure installation process without drilling. Follow these steps carefully:

1. Step 1: Clean the Surface

The surface where the shelf will be installed must be thoroughly cleaned with a clean, damp cloth. It is crucial that the surface is completely dry and free of grease, especially before application.

2. Step 2: Attach the Vacuum Adapter

Locate the mounting area on the back of the Vacuum-Loc adapter. Remove the protective film and firmly press the adapter onto the desired location. A positioning indicator helps ensure the adapter is correctly oriented.

3. Step 3: Create the Vacuum Seal

Place the Vacuum pump onto the adapter. Operate the pump until a loud 'clack' sound is heard. Remove the pump and repeat this pumping action three more times (total of four pumps). This creates the strong vacuum seal.

4. Step 4: Mount the Shelf

After completing the four pumping actions, the adapter is ready. Attach the shelf accessory to the installed Vacuum-Loc adapters. The shelf can be used immediately.





Figure 1: Visual guide to the Vacuum-Loc installation process.



- ✓ Fixing without drilling
- ✓ Extremely strong hold
- ✓ Repositionable as often as required and removable without residue
- ✓ Unique vacuum system

Figure 2: The WENKO Vacuum-Loc system eliminates the need for drilling.

4. OPERATING INSTRUCTIONS

Once installed, the WENKO Vacuum-Loc 2-Tier Wall Shelf provides convenient storage. Use the two tiers to hold various bathroom or kitchen items such as shampoo bottles, soaps, or spices. The two integrated hooks at the bottom are ideal for hanging washcloths, sponges, or small towels.



- ✓ **Two hooks for additional hanging options**
- ✓ **Lots of storage space on two trays**
- ✓ **Easy mounting**
- ✓ **Made of chrome plated steel**

Figure 3: The shelf provides ample storage for bathroom essentials.

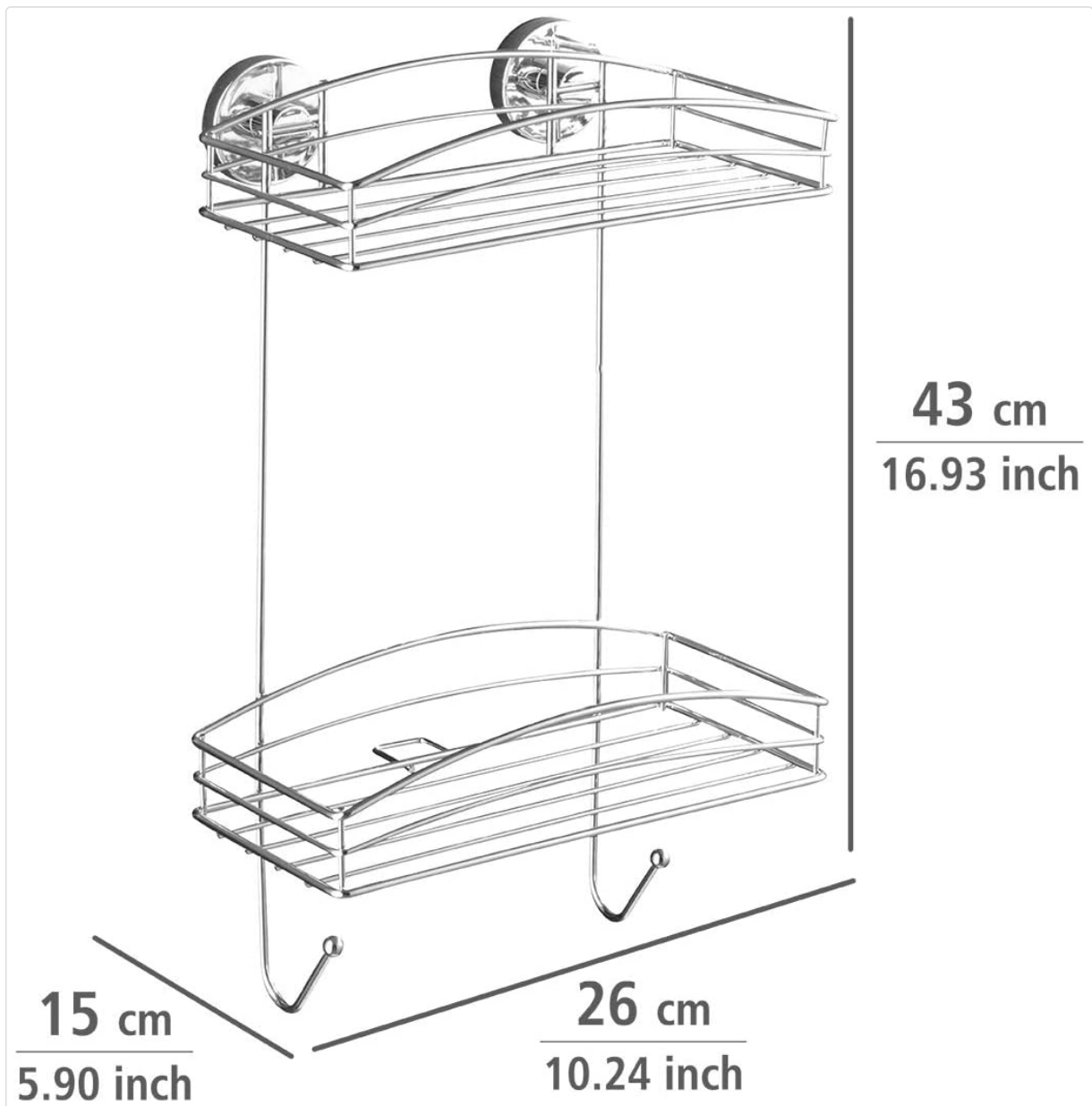

Figure 4: Features of the WENKO Vacuum-Loc shelf, including its two hooks and two storage trays.

5. MAINTENANCE

To maintain the appearance and longevity of your WENKO Vacuum-Loc shelf, regularly clean it with a soft, damp cloth. Avoid using abrasive cleaners, harsh chemicals, or scouring pads, as these can damage the chrome finish. Dry the shelf thoroughly after cleaning to prevent water spots.

6. TROUBLESHOOTING

Loss of Suction:

If the Vacuum-Loc shelf loses its hold or begins to detach, it may be due to an imperfect seal or a change in surface conditions. To resolve this:

- Remove the shelf and the Vacuum-Loc adapters.
- Thoroughly clean both the wall surface and the back of the adapters to ensure they are free of dust, moisture, or grease.
- Ensure the surface is completely dry before re-installation.
- Re-install the Vacuum-Loc adapters following the steps in Section 3, ensuring the pump is operated

four times until a strong 'clack' sound is heard each time.

7. SPECIFICATIONS

Brand	WENKO
Model Number	20886100
Material	Metal - Steel
Color	Chrome
Dimensions (L x W x H)	26 cm x 15.5 cm x 44 cm (10.24 in x 6.10 in x 17.32 in)
Unpacked Weight	920 g (2.03 lbs)
Maximum Supported Weight	33 kg (72.75 lbs)
Installation Method	Vacuum-Loc Wall Mounting (No Drilling)

VACUUM SYSTEM

VACUUM-LOC[®]



33 kg

1. Fix the vacuum adapter firmly
2. Press the pump against the Loc and pull out the pump piston until a loud plop is heard, repeat 4x
3. Attach the accessory
4. Open valve to release



Figure 5: Product dimensions for the WENKO Vacuum-Loc shelf.

8. WARRANTY AND SUPPORT

Specific warranty information for this product is not provided in this manual. For details regarding warranty coverage, returns, or technical support, please refer to the product packaging or contact WENKO customer service directly through their official website or the retailer from whom the product was purchased.