



Manuals.plus /

› Livarno /

› Livarno Stainless Steel Mailbox Model 87111 Instruction Manual

Livarno 87111

Livarno Stainless Steel Mailbox Model 87111 Instruction Manual

Model: 87111 | Brand: Livarno

1. INTRODUCTION

Thank you for choosing the Livarno Stainless Steel Mailbox Model 87111. This manual provides essential information for the safe and correct installation, operation, and maintenance of your new mailbox. Please read these instructions carefully before beginning installation and retain them for future reference.

Safety Information

- Ensure all mounting hardware is securely fastened to prevent the mailbox from falling.
- Keep keys in a safe place and away from children.
- Avoid using abrasive cleaners or materials that could scratch the stainless steel surface.
- Periodically check all connections and the lock mechanism for proper function.

2. PACKAGE CONTENTS

Please verify that all items listed below are included in your package:

- Livarno Stainless Steel Mailbox with integrated newspaper holder
- Cylinder lock (pre-installed)
- Keys (2 pieces)
- Mounting hardware (screws, wall plugs)
- Instruction Manual



Image 1: Front view of the Livarno Stainless Steel Mailbox, showing the mail slot and newspaper holder.

3. SETUP AND INSTALLATION

The Livarno Stainless Steel Mailbox is designed for wall mounting. Ensure you select a suitable location that is easily accessible and protected from direct heavy rain if possible, to prolong the life of your mail and

the mailbox.

Required Tools (Not Included):

- Drill
- Drill bit suitable for your wall type
- Pencil
- Measuring tape
- Level

Installation Steps:

1. **Choose Location:** Select a flat, sturdy wall surface for mounting. Consider the height for easy access to both the mail slot and the retrieval door.
2. **Mark Drill Holes:** Hold the mailbox against the wall at the desired mounting height. Use a pencil to mark the positions for the mounting holes on the wall. Ensure the mailbox is level before marking.
3. **Drill Holes:** Using an appropriate drill bit for your wall material, drill holes at the marked positions. The depth of the holes should match the length of the wall plugs.
4. **Insert Wall Plugs:** Insert the provided wall plugs into the drilled holes. Tap them gently with a hammer if necessary until they are flush with the wall surface.
5. **Mount Mailbox:** Align the mailbox's mounting holes with the wall plugs. Insert the screws through the mailbox and into the wall plugs. Tighten the screws firmly, but do not overtighten, to secure the mailbox to the wall.

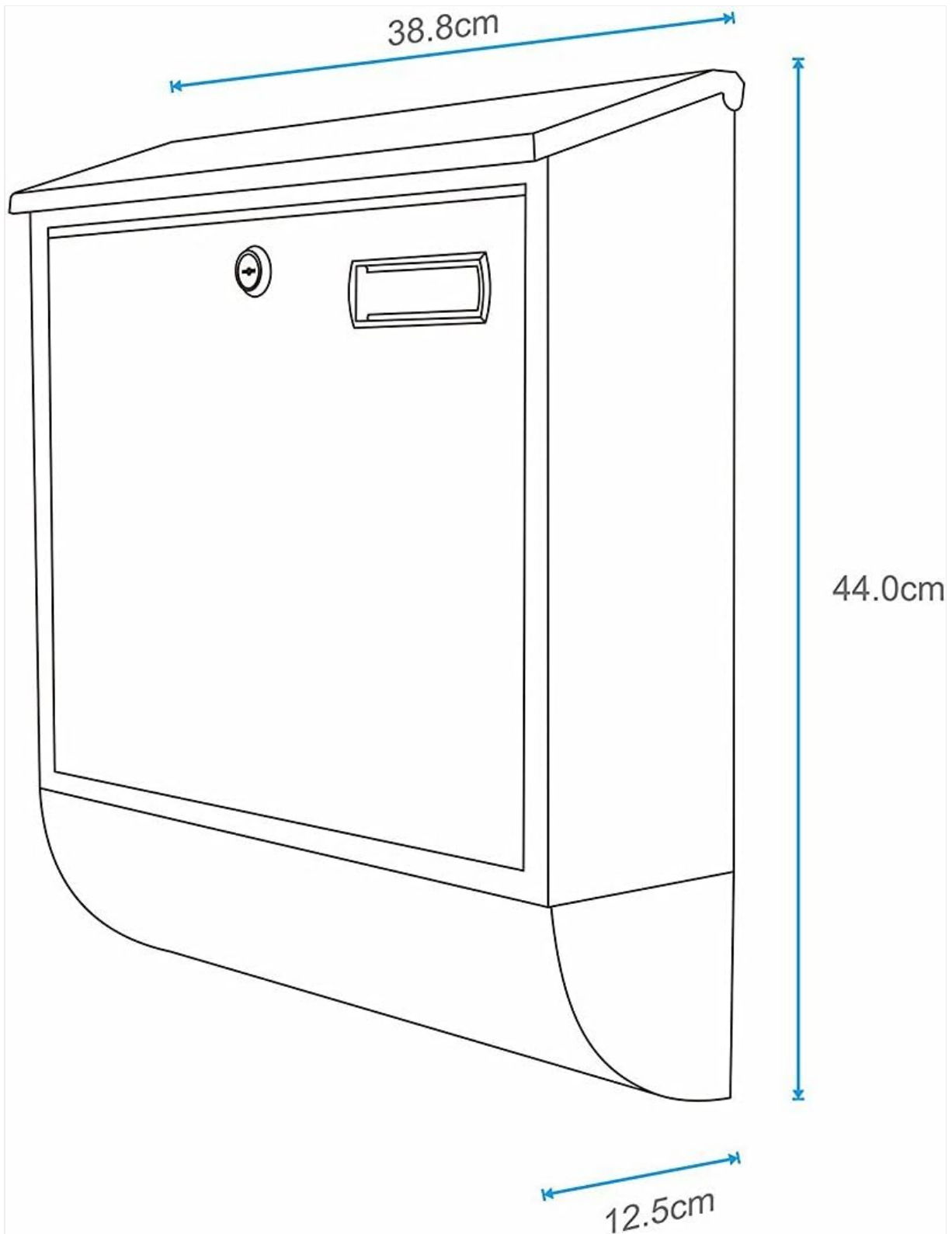

Image 2: Mailbox dimensions for installation planning. (Approx. 38.8 cm width, 44.0 cm height, 12.5 cm depth).

4. OPERATING INSTRUCTIONS

Inserting Mail

To insert letters or small packages, lift the top lid of the mailbox. The mail slot is located underneath. The mailbox is designed to accommodate letter formats up to C4 (22.9 x 32.4 cm).



Image 3: Inserting mail into the top slot.

Retrieving Mail

To retrieve your mail, use one of the provided keys to unlock the front retrieval door. Turn the key to unlock, then pull the door open. After retrieving your mail, close the door and turn the key to lock it securely.



Image 4: Opening the retrieval door with the key.

Using the Newspaper Holder

The integrated newspaper holder is located at the bottom of the mailbox. Newspapers and magazines can be easily slid into this open compartment for convenient access without needing to unlock the main mail compartment.



Image 5: Livarno Stainless Steel Mailbox with a newspaper in the integrated bottom holder.

5. MAINTENANCE

Regular maintenance will help preserve the appearance and functionality of your Livarno Stainless Steel Mailbox.

- **Cleaning:** Clean the stainless steel surface regularly with a soft, damp cloth and a mild detergent. For stubborn dirt or fingerprints, use a specialized stainless steel cleaner. Always wipe in the direction of the grain to avoid streaks.
- **Avoid Abrasives:** Do not use abrasive sponges, scouring pads, or harsh chemical cleaners, as these can damage the brushed finish and protective varnish.
- **Lock Care:** Periodically apply a small amount of graphite powder or a silicone-based lubricant to the lock mechanism to ensure smooth operation. Avoid oil-based lubricants as they can attract dust.
- **Inspection:** Annually inspect all mounting screws and the mailbox structure for any signs of loosening or damage. Tighten screws as needed.

6. TROUBLESHOOTING

Problem	Possible Cause	Solution
Key is difficult to turn or lock sticks.	Dust or debris in the lock mechanism; lack of lubrication.	Apply graphite powder or a silicone-based lubricant into the keyhole. Insert and turn the key several times to distribute the lubricant.
Mailbox appears loose on the wall.	Mounting screws have loosened over time.	Carefully tighten all mounting screws. If the issue persists, inspect wall plugs and consider using larger ones or relocating the mailbox.
Water inside the mailbox.	Extreme weather conditions; improper sealing during installation; damaged seals.	Ensure the top lid closes completely. Check for any gaps around the mounting points and seal with silicone caulk if necessary. Inspect the mailbox for any damage.

7. SPECIFICATIONS

Model: 87111 (S1258-D)

Brand: Livarno

Material: Stainless Steel

Color: Silver

Dimensions (W x H x D): Approximately 38.8 cm x 44.0 cm x 12.5 cm (15.3 in x 17.3 in x 4.9 in)

Weight: Approximately 4.08 kg (9 lbs)

Letter Format Capacity: Up to C4 (22.9 x 32.4 cm / 9.0 x 12.8 in)

Security Features: Lockable retrieval compartment with cylinder lock

Mounting Type: Wall-mount

Access Location: Front (for mail retrieval door)

8. WARRANTY AND SUPPORT

For warranty information or technical support, please refer to the purchase documentation or contact your retailer. Keep your proof of purchase for any warranty claims.

Manufacturer: Owim GmbH

