

Manuals.plus /

- › Gorilla Sports GmbH /
- › Gorilla Sports Universal Weight Bench and 108 kg Barbell Set - Chrome Instruction Manual

Gorilla Sports GmbH 100413-00004-0049

Gorilla Sports Universal Weight Bench and 108 kg Barbell Set - Chrome Instruction Manual

Model: 100413-00004-0049

1. PRODUCT OVERVIEW

The Gorilla Sports Universal Weight Bench and 108 kg Barbell Set is designed for comprehensive strength training in a home gym environment. This versatile fitness station includes a weight bench with a barbell holder, a curl bench, leg extension and leg curl attachments, dip handles, and a butterfly station. It comes complete with a 108 kg barbell set, providing a robust foundation for a balanced full-body muscle workout.

Constructed with a stable steel tube frame, the unit supports heavy weights with high stability, ensuring a safe workout experience. The comfortable black artificial leather upholstery is designed for durability and easy cleaning, maintaining a firm lying position even during intense training. The included chrome barbells are suitable for a wide range of exercises, from deadlifts and shoulder presses to squats and bicep/tricep training. Non-slip feet with rubber caps enhance safety and stability during use.



Image 1.1: The Gorilla Sports Universal Weight Bench with the included 108 kg barbell set, showcasing its various components for a complete home workout.

2. SAFETY INFORMATION

- Read all instructions carefully before assembly and use. Keep this manual for future reference.
- Consult a physician before starting any exercise program.
- Ensure all bolts, nuts, and connections are securely tightened before each use. Regularly check for loose parts.
- Place the equipment on a flat, stable surface. Use a protective mat if necessary.
- Keep children and pets away from the equipment during use.
- Do not exceed the maximum weight capacity of 280 kg for the bench.
- Wear appropriate athletic attire and footwear.
- Stop exercising immediately if you feel pain, dizziness, or nausea.
- Perform warm-up exercises before and cool-down exercises after your workout.
- Always use spotters when lifting heavy weights, especially during bench press exercises.

3. PACKAGE CONTENTS

Verify that all components are present and undamaged before beginning assembly. If any parts are missing or damaged, contact Gorilla Sports customer service.

- Universal Weight Bench frame and components
- Adjustable backrest and seat pads

- Curl bench attachment
- Leg extension/curl attachment
- Dip handles
- Butterfly station components
- 108 kg Barbell Set (various weight plates, barbells, and dumbbell bars)
- Assembly hardware (bolts, nuts, washers, tools)
- Instruction Manual



Image 3.1: Individual components of the 108 kg barbell set, including various weight plates and bars.



Image 3.2: The assembled 108 kg barbell set, featuring a straight barbell, an EZ curl bar, and two dumbbell bars with weight plates.

4. ASSEMBLY INSTRUCTIONS

Assembly typically requires two people for ease and safety. Follow the numbered steps provided in the separate assembly diagram (if included) or the detailed instructions below. Ensure all parts are correctly oriented before tightening.

1. **Unpack Components:** Carefully remove all parts from the packaging and lay them out on a clean, flat surface. Check against the package contents list.
2. **Assemble Main Frame:** Connect the base stabilizers to the main uprights using the provided bolts and nuts. Do not fully tighten until all major frame components are in place.
3. **Attach Bench Support:** Secure the bench support frame to the main uprights.
4. **Install Backrest and Seat:** Attach the backrest and seat pads to their respective adjustable mechanisms. Ensure they can be adjusted smoothly.
5. **Mount Attachments:** Install the curl bench, leg extension/curl, dip handles, and butterfly station according to the diagrams. Pay attention to the correct orientation of each part.

6. **Final Tightening:** Once all components are assembled, systematically tighten all bolts and nuts. Do not overtighten.

7. **Stability Check:** Gently shake the assembled bench to ensure it is stable and all connections are secure.

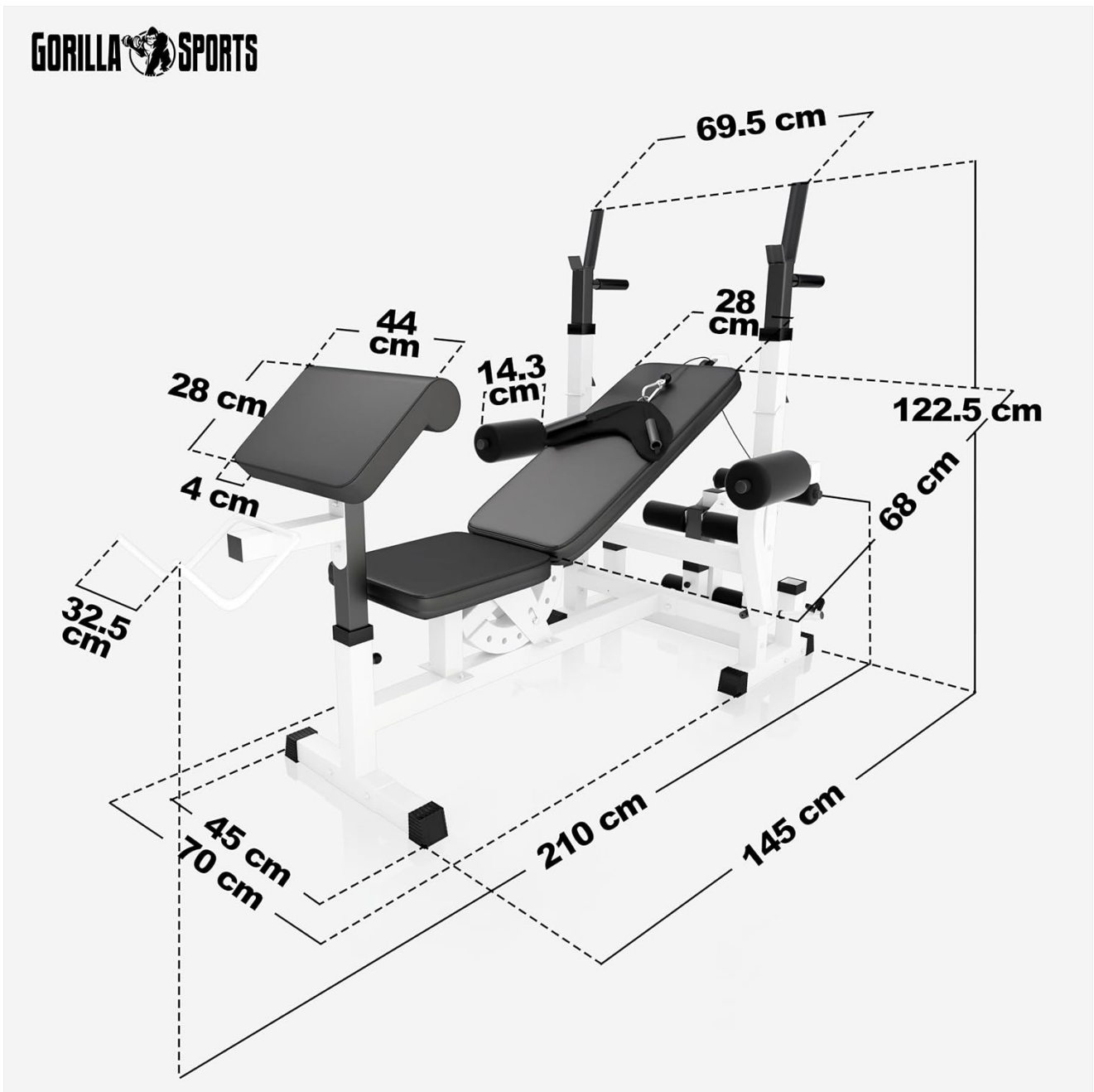

Image 4.1: A diagram illustrating the key dimensions of the Universal Weight Bench, useful for planning space and assembly.

5. OPERATING INSTRUCTIONS AND USAGE

This universal weight bench offers multiple exercise options. Always ensure the bench is adjusted correctly and securely locked before starting an exercise.

5.1. Adjusting the Bench

- The backrest can be adjusted to various incline, flat, and decline positions. Locate the adjustment pin or lever, pull it out, set the backrest to the desired angle, and ensure the pin locks securely into place.
- The seat may also have adjustable positions to complement the backrest angle.



Image 5.1: Illustration of the adjustable backrest, showing how it can be moved through different positions.

5.2. Using the Barbell Holder

- The barbell holder is designed to safely rack barbells for exercises like bench press. Ensure the barbell is centered and securely seated on the hooks.
- Adjust the height of the barbell holder if possible, to match your arm length and exercise requirements.



Image 5.2: Close-up view of the barbell rack, highlighting the secure resting points for barbells and the integrated dip handles.

5.3. Leg Extension and Curl

- Attach weight plates to the designated post on the leg attachment.
- For leg extensions, sit on the bench with your shins under the padded rollers. Extend your legs.
- For leg curls, lie face down on the bench (if applicable) or sit facing the attachment with your heels under the rollers. Curl your legs.

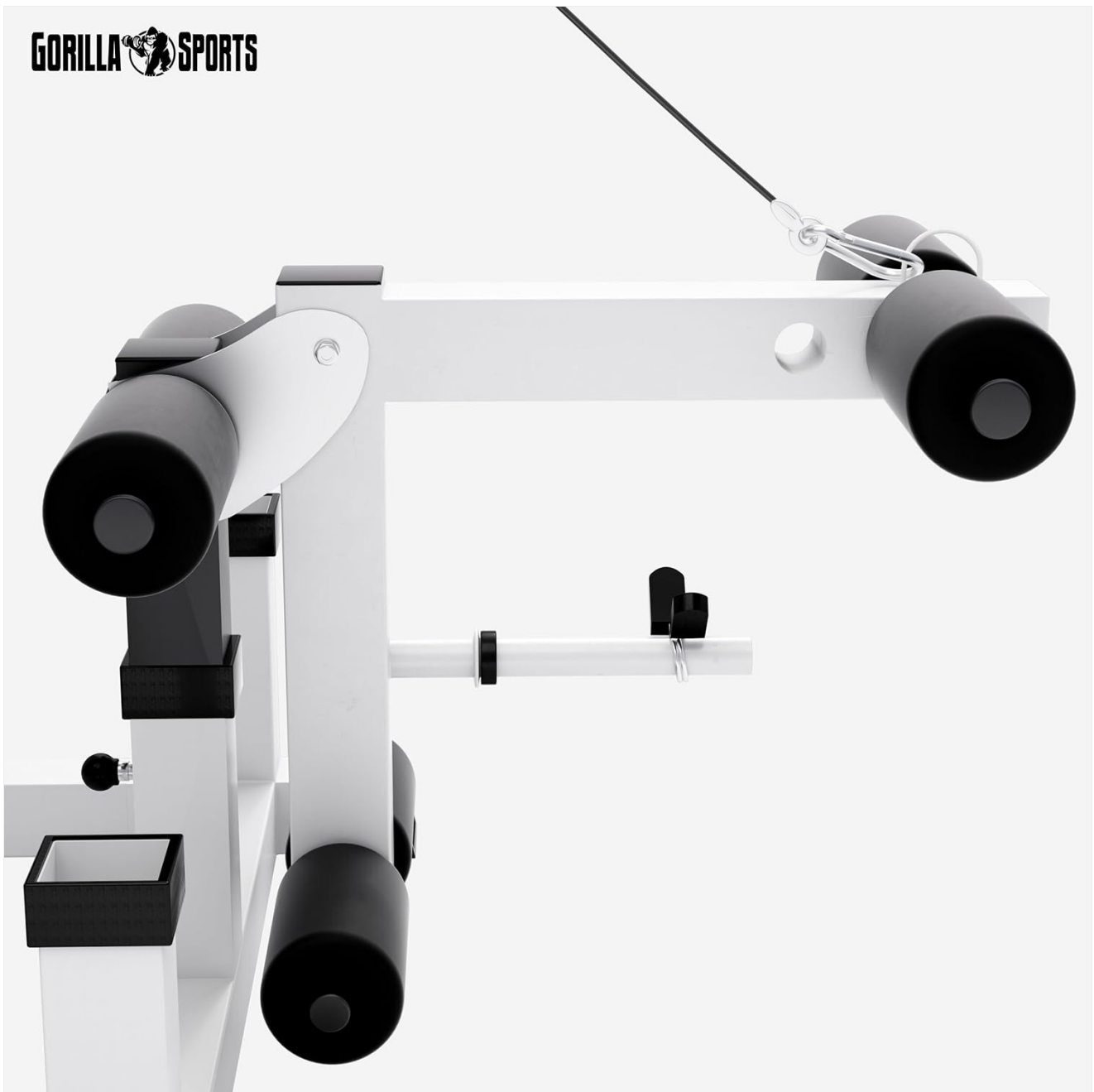

Image 5.3: A detailed view of the leg curl and extension attachment, showing the padded rollers and weight plate post.

5.4. Curl Bench (Preacher Curl)

- Position yourself with your arms over the padded curl bench.
- Use an EZ curl bar or dumbbells to perform bicep curls, ensuring full range of motion.



Image 5.4: A close-up of the preacher curl pad, designed for isolating bicep muscles during curls.

5.5. Dip Handles and Butterfly Station

- The integrated dip handles allow for bodyweight dips. Ensure a stable grip and controlled movement.
- The butterfly station is used for chest fly exercises. Sit on the bench, place your forearms against the pads, and bring them together in a controlled motion.

6. MAINTENANCE

- **Cleaning:** Wipe down the upholstery and frame with a damp cloth after each use to remove sweat and dust. Use mild soap if necessary, and dry thoroughly. Avoid abrasive cleaners.
- **Inspection:** Regularly inspect all bolts, nuts, and moving parts for tightness and wear. Tighten any loose fasteners. Check cables (if any) for fraying or damage.
- **Lubrication:** Apply a small amount of silicone-based lubricant to pivot points or moving parts if they become stiff or noisy.
- **Storage:** Store the equipment in a dry, temperate environment away from direct sunlight and extreme

temperatures.

7. TROUBLESHOOTING

Problem	Possible Cause	Solution
Bench feels unstable or wobbly.	Loose bolts or uneven surface.	Ensure all assembly bolts are securely tightened. Move the bench to a flat, level surface.
Attachments are stiff or difficult to adjust.	Lack of lubrication or minor misalignment.	Apply silicone lubricant to pivot points. Check for any obstructions or misaligned parts.
Noise during operation.	Loose connections or friction between parts.	Inspect and tighten all bolts. Lubricate moving parts as needed.
Upholstery wear or damage.	Normal wear and tear or improper cleaning.	Clean regularly with mild soap and water. Avoid sharp objects. Contact customer service for replacement parts if severe.

8. SPECIFICATIONS

Model Number: 100413-00004-0049

Brand: Gorilla Sports GmbH

Color: Chrome (for barbell set), Black/White (for bench)

Frame Material: Alloy Steel

Upholstery Material: Artificial Leather

Maximum Weight Capacity: 280 kg

Product Dimensions (L x W x H): 210 x 70 x 122.5 cm

Item Weight: 154.5 kg

Barbell Set Weight: 108 kg

9. WARRANTY AND SUPPORT

For warranty information, technical support, or to order replacement parts, please contact Gorilla Sports customer service. Refer to your purchase documentation for specific warranty terms and contact details.

You can typically find support information on the official Gorilla Sports website or through the retailer where the product was purchased.