



[Manuals.plus](#) /

> [GORILLA SPORTS](#) /

> Gorilla Sports Universal Weight Bench with Barbell Racks - User Manual

GORILLA SPORTS 100115-00022-0001

Gorilla Sports Universal Weight Bench with Barbell Racks - User Manual

Model: 100115-00022-0001

1. INTRODUCTION

Thank you for choosing the Gorilla Sports Universal Weight Bench. This versatile fitness equipment is designed to provide a comprehensive workout for various muscle groups, including arms, shoulders, back, chest, abdominals, and legs. This manual provides essential information for safe assembly, operation, and maintenance of your new weight bench. Please read it thoroughly before use.



Figure 1: The Gorilla Sports Universal Weight Bench, showcasing its multi-functional design with barbell rests, a bench, and various attachments.

2. SAFETY INFORMATION

WARNING: Failure to follow these safety instructions may result in serious injury or death.

- Consult a physician before beginning any exercise program.
- Keep children and pets away from the equipment during use.
- Ensure all bolts, nuts, and connections are securely tightened before each use.
- Do not exceed the maximum weight capacities specified in this manual.
- Use spotters when lifting heavy weights, especially during bench press exercises.
- Place the bench on a flat, stable surface. Non-slip rubber feet are provided to protect your floor.
- Inspect the equipment for wear and tear before each workout. Do not use if any parts are damaged.
- Wear appropriate athletic footwear and clothing.
- Do not attempt to modify the equipment.

3. PACKAGE CONTENTS

Your Gorilla Sports Universal Weight Bench is typically shipped in two packages. Please ensure you have received all components before beginning assembly.

- Main Frame Components (various steel tubes)
- Backrest Cushion
- Seat Cushion
- Preacher Curl Cushion
- Leg Curl/Extension Attachment
- Barbell Rests with Dip Handles
- All necessary Nuts, Bolts, Washers, and Pins (often shrink-wrapped on a cardboard sheet for easy identification)
- Assembly Tools (basic wrenches)

4. ASSEMBLY INSTRUCTIONS

Assembly typically takes 1-1.5 hours. It is recommended to have two people for easier and safer assembly. Clear a spacious area and lay out all components.

1. **Unpack and Identify Parts:** Carefully remove all components from the packaging. Refer to the included parts diagram (if available) and the labeled hardware to identify each piece.
2. **Assemble the Main Base Frame:** Connect the front and rear stabilizer bars to the main frame using the specified bolts and washers. Ensure all connections are finger-tight at this stage.
3. **Attach the Barbell Racks:** Secure the vertical barbell support posts to the main frame. These posts also house the dip handles.
4. **Install the Bench and Backrest:** Attach the seat cushion to its designated frame. Then, connect the adjustable backrest frame to the main bench structure. The backrest can be adjusted to 6 different positions.
5. **Mount the Leg Curl/Extension Attachment:** Insert the leg curl/extension attachment into its receiver on the front of the bench. This attachment is adjustable in 3 positions for thigh press.
6. **Attach the Preacher Curl Attachment:** Insert the preacher curl pad and its support arm into the designated receiver. The curl cushion is adjustable in 3 positions.
7. **Final Tightening:** Once all components are in place, systematically tighten all bolts and nuts using the provided tools or a socket set for better leverage. Ensure all connections are firm and secure.
8. **Check Stability:** Gently shake the assembled bench to ensure it is stable and all parts are securely fastened.

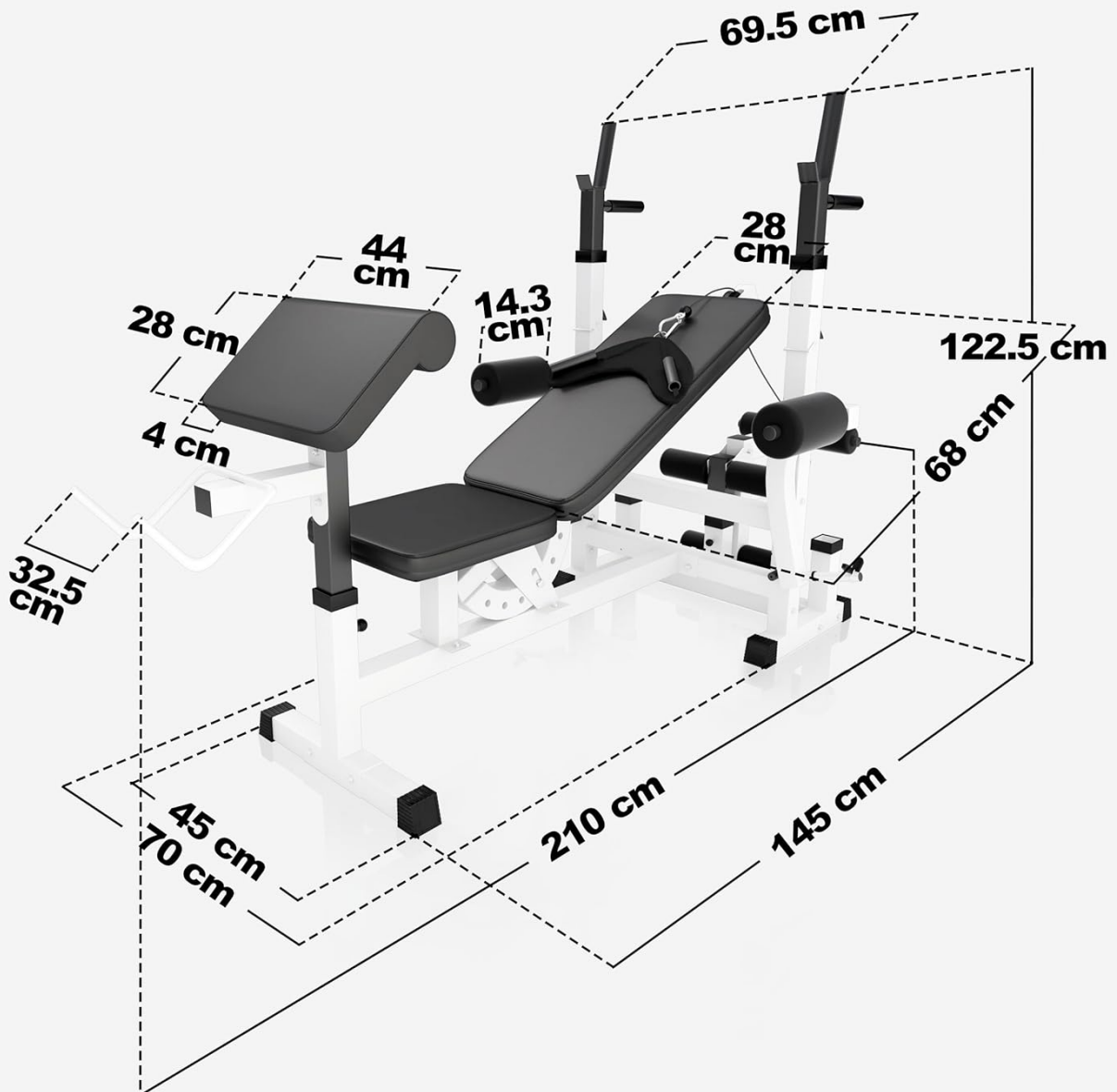

Figure 2: Detailed dimensions of the assembled weight bench, useful for planning your workout space and understanding component sizes during assembly.

5. OPERATING INSTRUCTIONS

The Gorilla Sports Universal Weight Bench offers multiple adjustment points and attachments to customize your workout.

5.1. Adjusting the Bench

- **Backrest Adjustment:** The backrest cushion can be adjusted to 6 different incline positions, from flat to an upright 90-degree angle, suitable for various chest and shoulder exercises. To adjust, pull the pin, set to desired angle, and re-insert the pin securely.
- **Curl Cushion Adjustment:** The preacher curl cushion is adjustable to 3 positions to accommodate different arm lengths and exercise preferences.
- **Thigh Press Adjustment:** The leg curl/extension attachment can be adjusted to 3 positions for optimal

comfort and range of motion during leg exercises.

- **Barbell Rest Adjustment:** The barbell rests are adjustable to 5 different height levels, ranging from 90 cm to 110 cm, to suit various exercises and user heights. Ensure the safety catch is engaged after adjustment.



Figure 3: The adjustable backrest of the bench, demonstrating its multiple incline positions for varied exercises.

5.2. Using Attachments

- **Leg Curl/Extension:** Use this attachment for exercises targeting your quadriceps and hamstrings. Load appropriate weight plates onto the post. Maximum load for leg curler is 60 kg.
- **Preacher Curl:** Attach the preacher curl pad for isolated bicep and tricep exercises. Place your arms over the pad and perform curls with dumbbells or a curl bar.
- **Dip Handles:** The integrated dip handles on the barbell rests allow for bodyweight dips, targeting chest, shoulders, and triceps. Maximum load for dip handles is 60 kg per handle (120 kg total).
- **Butterfly (Optional):** If you have the optional butterfly attachment, it can be used for chest fly exercises. Maximum load for butterfly is 40 kg per arm.
- **Pulley System (Optional):** An optional pulley system is available from Gorilla Sports to expand the exercise

possibilities, allowing for lat pulldowns and other cable exercises.

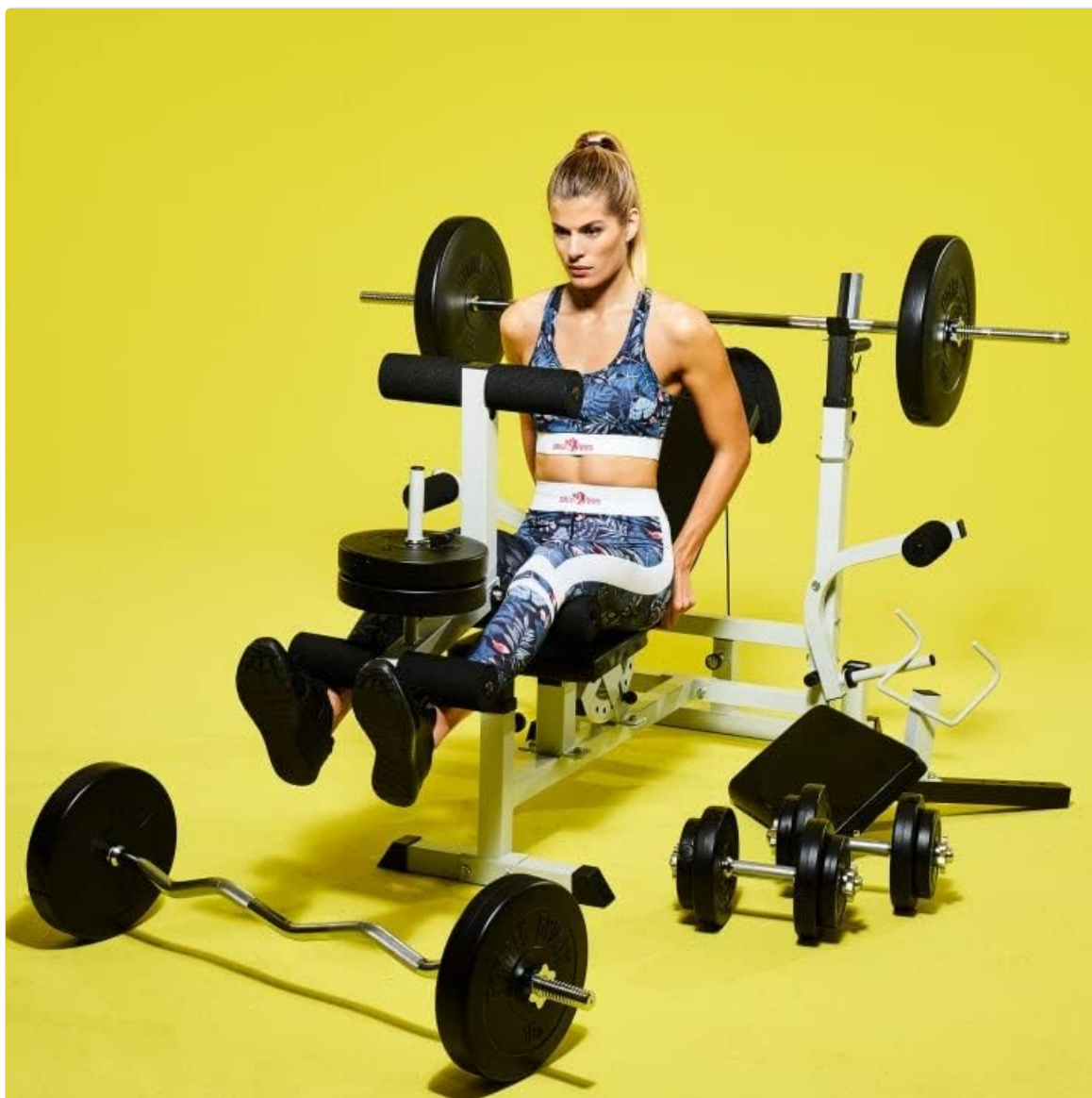

Figure 4: A user demonstrating the leg curl exercise using the front attachment, highlighting its functionality for lower body workouts.

6. MAINTENANCE

- **Cleaning:** Wipe down the bench and cushions with a damp cloth after each use to remove sweat and dirt. Use mild soap if necessary, but avoid harsh chemicals.
- **Inspection:** Regularly inspect all bolts, nuts, and moving parts for tightness. Tighten any loose fasteners. Check for any signs of wear, cracks, or damage to the frame, cushions, or attachments.
- **Lubrication:** Apply a small amount of silicone-based lubricant to any moving joints or pivot points if they begin to squeak or feel stiff.
- **Storage:** Store the bench in a dry, clean environment away from direct sunlight and extreme temperatures.

7. TROUBLESHOOTING

Problem	Possible Cause	Solution
Bench feels wobbly or unstable.	Loose bolts or uneven surface.	Ensure all bolts are tightened. Move the bench to a flat, level surface.
Parts do not fit together during assembly.	Incorrect orientation or missing hardware.	Refer to the assembly instructions and diagrams. Ensure correct parts are used and oriented properly. Do not force parts.
Squeaking noises during use.	Dry joints or loose connections.	Lubricate moving joints with silicone spray. Check and tighten all bolts.
Cushions show signs of wear.	Normal wear and tear or improper cleaning.	Clean regularly with mild soap. Consider replacement cushions if heavily worn.

8. TECHNICAL SPECIFICATIONS

Feature	Specification
Model Number	100115-00022-0001
Overall Dimensions (L x W x H)	180 cm x 70 cm x 90-110 cm (height adjustable)
Backrest Cushion Dimensions (L x W x H)	68 cm x 28 cm x 4 cm
Curl Cushion Dimensions (L x W x H)	28 cm x 44.5 cm x 4 cm
Product Weight	40 kg
Maximum Total Load Capacity (User + Weights)	280 kg
Maximum Barbell Rest Load	180 kg
Maximum Butterfly Load (per arm)	40 kg
Maximum Leg Curler Load	60 kg
Maximum Dip Handle Load (per handle)	60 kg (120 kg total)
Barbell Rest Diameter	25 mm (compatible with 26 mm and 31 mm bore weights)
Material	Alloy Steel frame, Rubber feet
Color Options	Black or White

9. WARRANTY AND CUSTOMER SUPPORT

Gorilla Sports products are manufactured to high-quality standards. This product comes with a standard manufacturer's warranty against defects in materials and workmanship. Please retain your proof of purchase for warranty claims.

For technical assistance, missing parts, or warranty inquiries, please contact Gorilla Sports customer support through their official website or the retailer where you purchased the product. Provide your model number (100115-00022-0001) and ASIN (B002VG63PW) for faster service.

For more information and additional products, visit the official Gorilla Sports website:www.gorillasports.com