

ANALOG DEVICES DC3092A Evaluation Board Instruction Manual

[Home](#) » [Analog Devices](#) » [ANALOG DEVICES DC3092A Evaluation Board Instruction Manual](#) 

Contents

- [1 ANALOG DEVICES DC3092A Evaluation Board](#)
- [2 THEORY OF OPERATION](#)
- [3 PARTS LIST](#)
- [4 SCHEMATIC DIAGRAM](#)
- [5 Documents / Resources](#)
 - [5.1 References](#)
- [6 Related Posts](#)



ANALOG DEVICES DC3092A Evaluation Board

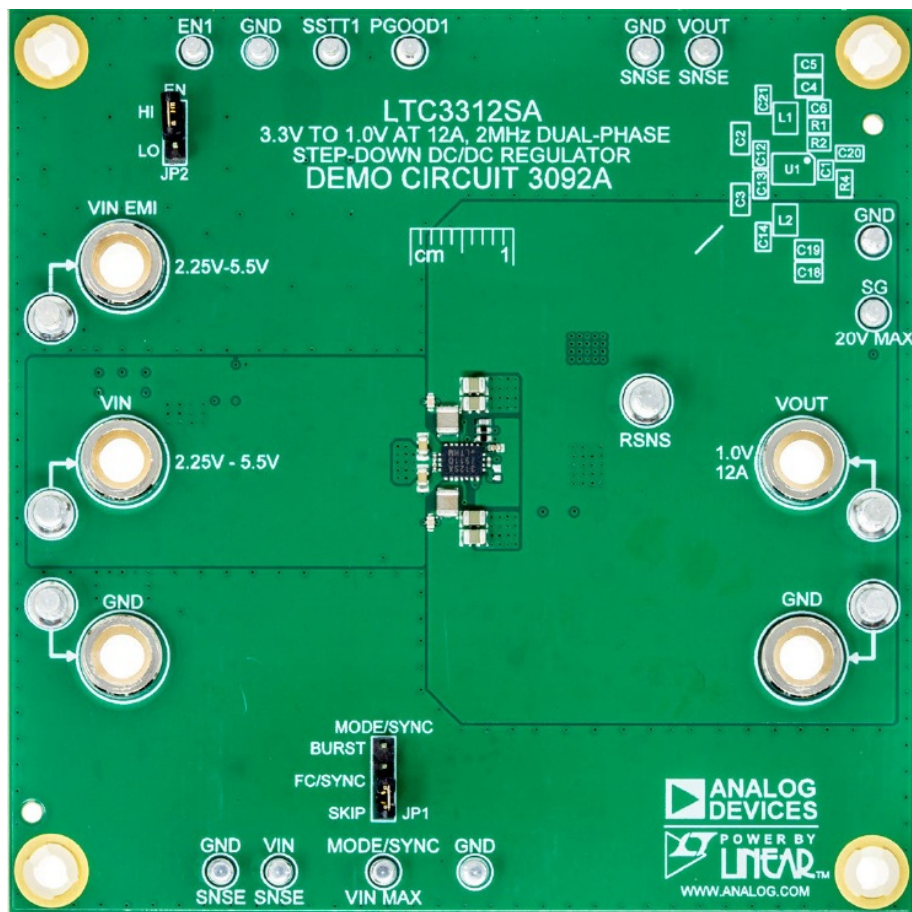

DESCRIPTION

Demo Circuit 3092A features the LTC3312SA, 5V, dual 6A/dual-phase 12A step-down DC/DC regulator IC. This demo circuit is configured as a 2-phase, 2MHz, 3.3V input, single 1V output, 12A buck regulator. The top switches are 180-degree out of phase to reduce the output ripple.

The LTC3312SA features dual monolithic synchronous 6A step-down power stages in a 3mm × 4mm package for space saving applications with demanding performance requirements. Both bucks achieve high efficiency and fast transient response with low external component count. The LTC3312SA can also be configured as a dual output, 6A per output, step-down converter. Please refer to DC3091A as a dual output application example. The LTC3312SA data sheet gives a complete description of its operation and application information. The data sheet must be read in conjunction with this demo manual when evaluating or modifying this demo circuit. DC3092A supports three operation modes, including pulse skip, forced continuous, and Burst Mode® operation. The clock frequency and the operation mode are shared by both buck phases. User can select desired operation mode with JP1 jumper. Setting JP1 to FC/SYNC position also allows the LTC3312SA to sync to a clock frequency from 1MHz to 3MHz, operating in forced continuous mode. An EMI filter is included in this demo circuit for noise sensitive applications. To power with EMI filter, please apply input voltage via VIN EMI terminal.

Design files for this circuit board are available.

PERFORMANCE SUMMARY

Specifications are at TA = 25°C

SYMBOL	PARAMETER	CONDITIONS	MIN	TYP	MAX	UNITS
VIN/VIN EMI	DC3092A Input Voltage Range		2.25		5.5	V
VOUT	DC3092A Output Voltage Range		0.98	1	1.02	V
IOUT	DC3092A Output Current			12		A
fSW	Switching Frequency		1.8		2.2	MHz
EFF	Efficiency	VIN = 3.3V, IOUT = 6A		91		%

BOARD PHOTO

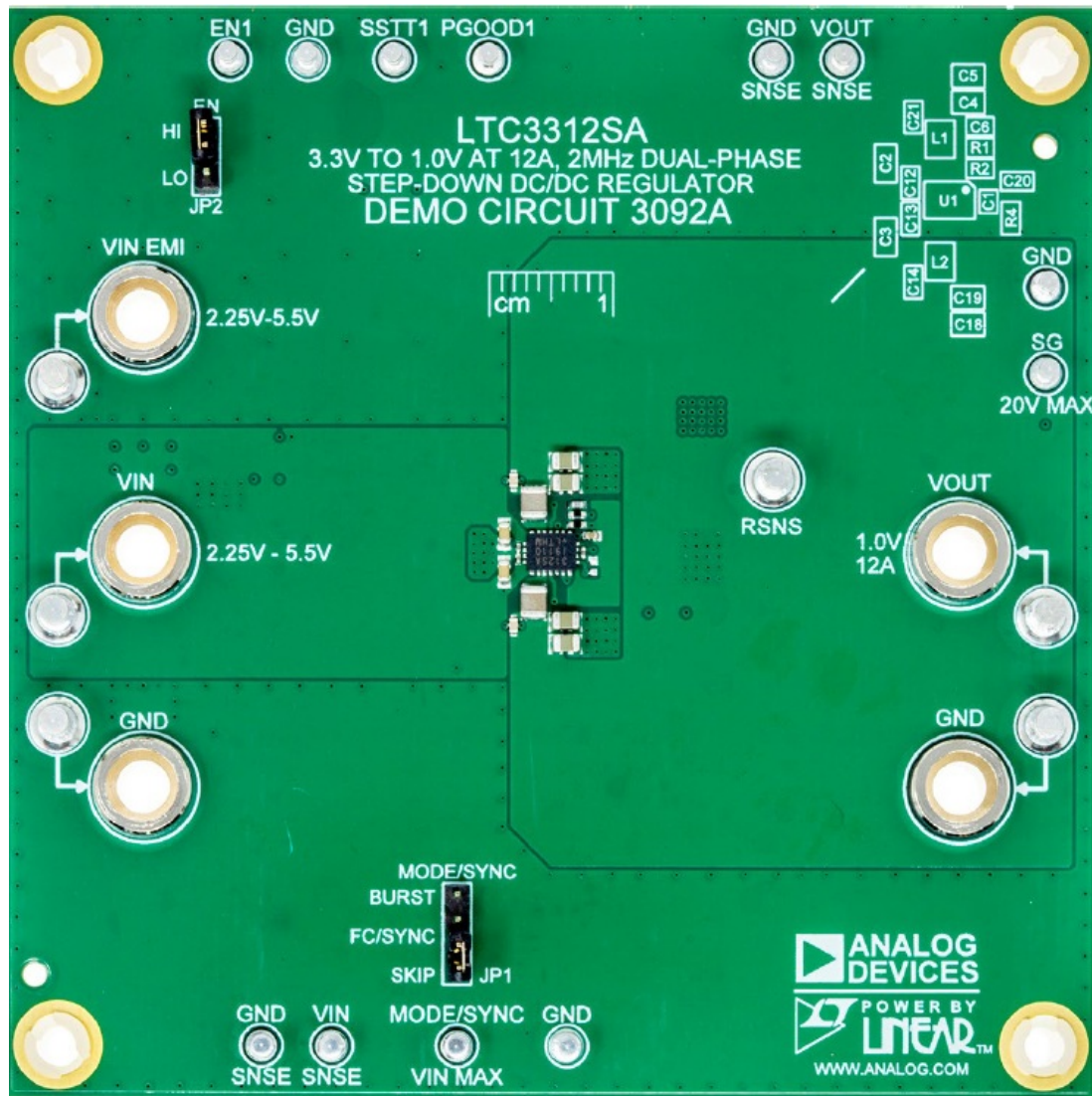

- DC3092A Demo Board

QUICK START PROCEDURE

Refer to Figure 2 for the proper measurement equipment setup and follow the procedure below:

NOTE:

For accurate VIN, VOUT and efficiency measurements, measure VIN at the VIN SNSE and GND SNSN turrets, and measure VOUT at the VOUT SNSE and GND SNSE turrets. When measuring the input or output ripple, care must be taken to avoid a long ground lead on the oscilloscope probe. It is recommended to use technique shown in Figure 3a and Figure 3b for basic ripple measurement.

Prepare for The Test

- A Select a power supply PS1 that can handle 5V of output voltage and 10A of output current, with internal current meter. If possible, connect PS1 Kelvin Sense terminals with VIN SNSE and GND SNSE turrets.
- B Select an electronic load LD1 can handle 1.5V of load voltage and up to 12A of load current in constant current mode.
- C Select an oscilloscope with two or more channels and two voltage probes.

QUICK START PROCEDURE

1. Connect PS1, LD1, VM1, VM2 and VM3 as shown in Figure 2. If the input EMI filter is desired, connect the input power supply to VIN EMI and GND.

2. Set the JP2 to HI position. Set LD1 to 0A. Slowly increase PS1 to 1.0V. If PS1 current reads less than 20mA, increase PS1 to 3.3V until VM1 reads $3.3V \pm 10mV$. PS1 current should read between 1mA to 5mA. VM2 should read between 0.98V to 1.02V. VM3 should read above 3V.
3. Connect an oscilloscope voltage probe as shown in Figure 3a, between VOUT SNSE and GND SNSE turrets. Set channel to AC-coupled, voltage scale to 20mV, and time base to $10\mu s/div$. Check VOUT ripple voltage. Output voltage ripple can also be measured with a low inductance connector on TP1, as shown in Figure 3b.
4. Increase the load by 1A intervals up to 12A and observe the voltage output regulation, ripple voltage, SW behavior and the voltage on the SSTT1 turret. Calculate Die temperature using the formula below:

$$T_J(^{\circ}C) = \frac{V_{SSTT}}{4mV} - 273 \quad (1)$$

5. If other operation modes are desired. Turn off PS1, set LD1 to 0A and set JP1 to FC/SYNC or BURST position. Turn on PS1, slowly increase LD1 and observe the change in PS1 output current, SW behavior and output ripple.
6. Optional: To change the frequency, remove R9. Install the desired RT resistor in the R4 location. Size the inductor, output capacitors and compensation components to provide the desired inductor ripple and a stable output. Refer to the LTC3312SA data sheet and LTPowerCAD for more information on choosing the required components.
7. Optional: To SYNC to a specific frequency, set JP1 to FC/SYNC position. Connect a waveform generator to MODE/SYNC turret. Please refer to LTC3312SA data sheet for synchronization signal requirements.
8. To test the transient response with a base load, add the desired resistor to produce a minimum load between VOUT and RSNS1 turrets (R_L shown on Figure 2). Note that the total load resistance will be R_L plus R_{11} ($20m\Omega$). Adjust a signal generator with a 10ms period, 10% duty cycle and an amplitude from 1V to 2V to start.
9. Measure the RSNS1 voltage to observe the current, $V_{RSNS1}/20m\Omega$. Adjust the amplitude of the pulse to provide the desired transient. Connect signal generator SG1 between SG_INPUT and GND turrets. Adjust the rising and falling edge of the pulse to provide the desired ramp rate. Refer to the following equations for output current measurement:

$$I_{OUT} = \frac{V_{RSNS1}}{20m\Omega} \quad (2)$$

10. When done, turn off SG1, PS1 and Load.

TEST SETUP

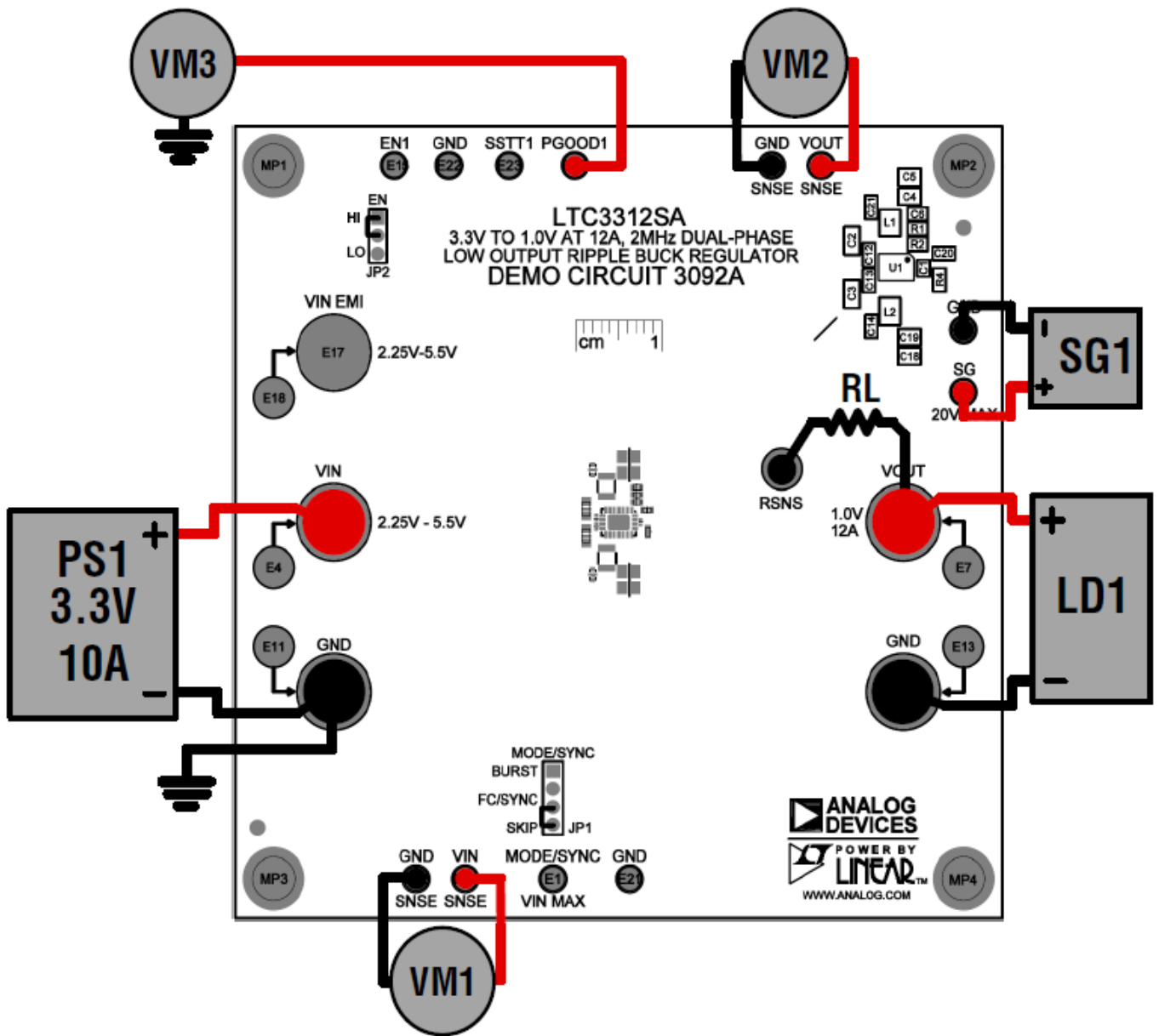

- Test Setup for DC3092A Demo Board

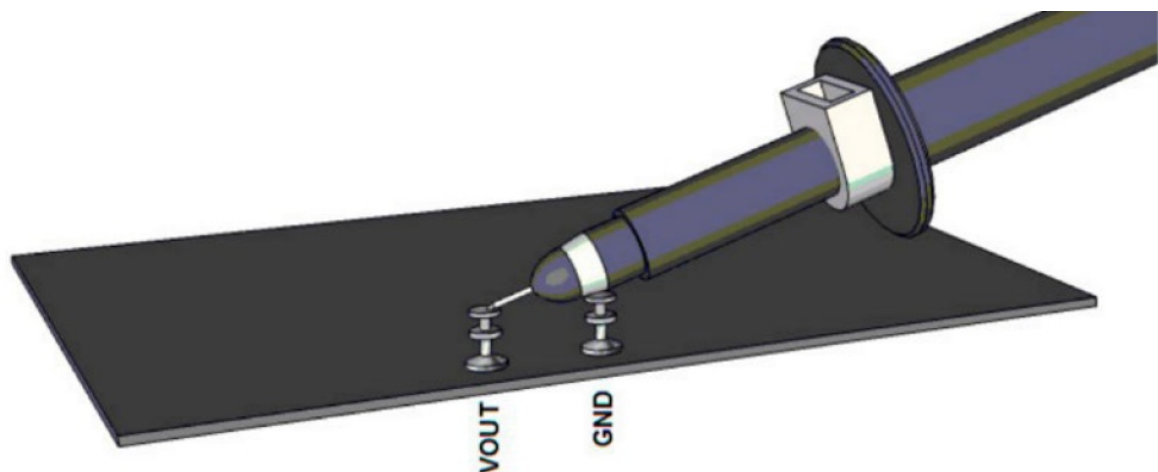

- Technique for Measuring Output Ripple and Step Response with a Scope Probe



**TP1
VOUT**

- Technique for Measuring Output Ripple and Step Response with a Low Inductance Connector (Not Supplied)

TYPICAL PERFORMANCE CHARACTERISTICS

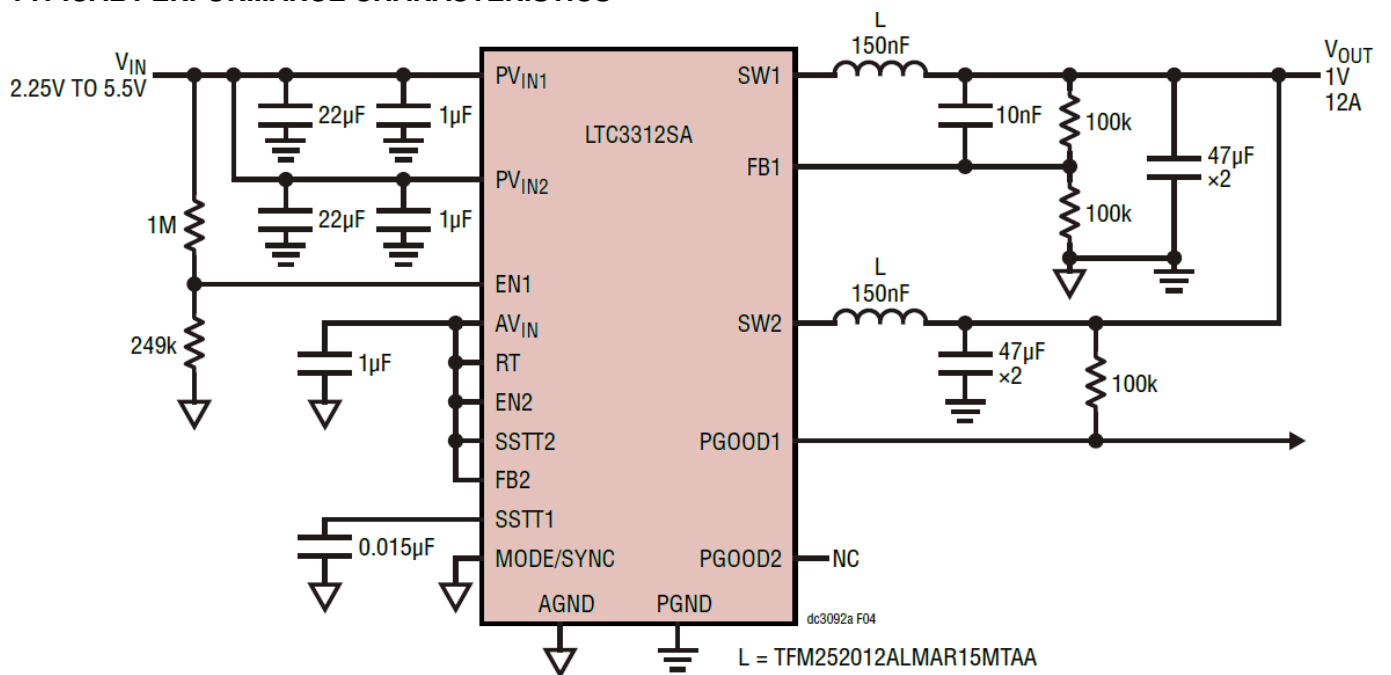

- LTC3312SA 2-Phase 2MHz 12A Buck Typical Application Schematic

Dual Phase Efficiency vs Load, 3.3V to 1V, fSW = 2MHz

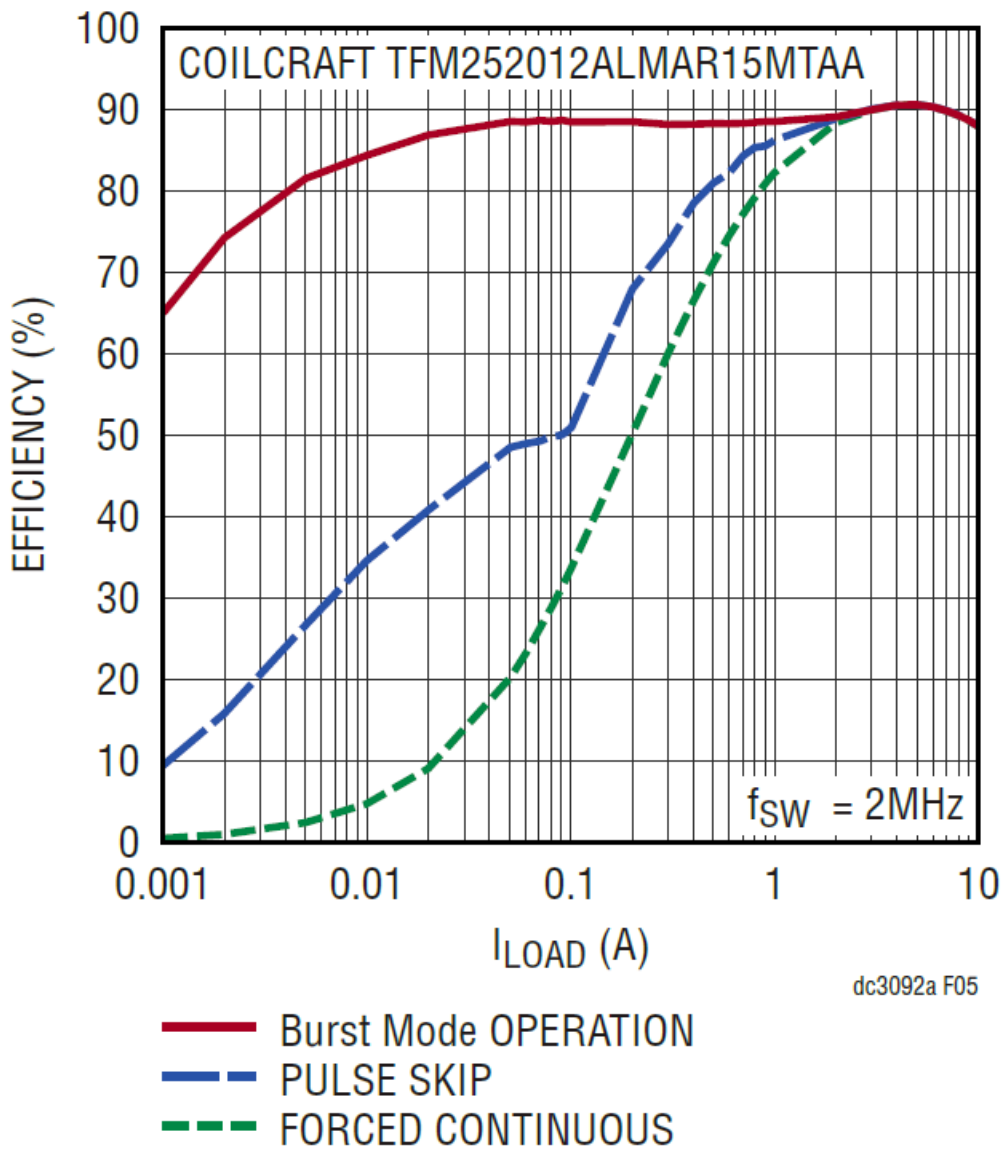

- Efficiency vs Load

Dual Phase Configuration Load Transient Response, Forced Continuous Mode

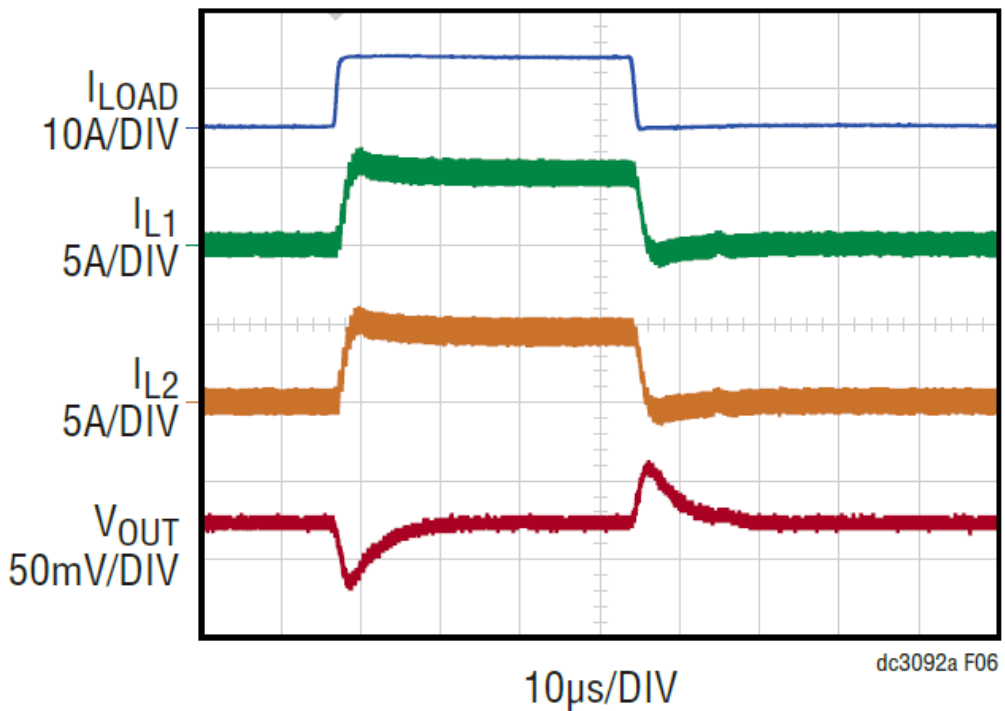

- Load Step Response

EMI TEST RESULTS

CISPR25 Conducted Emission Test with Class 5 Peak Limits (Voltage Method) (Supply)

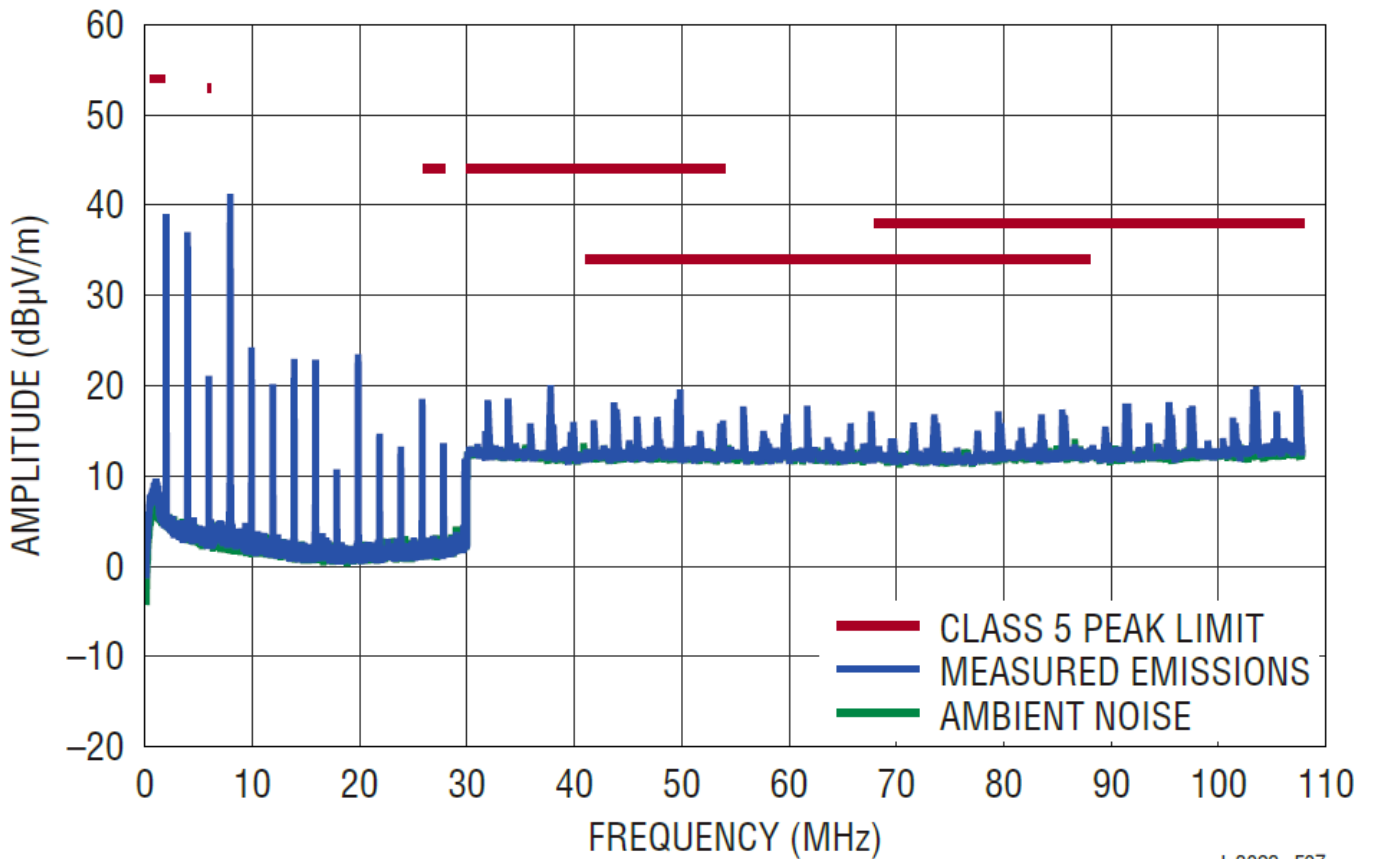

dc3092a F07

- DC3092A DEMO BOARD
(WITH VOLTAGE APPLIED TO VIN EMI INPUT)
3.3V INPUT TO 1V OUTPUT AT 9.6A, f_{SW} = 2MHz
- CISPR25 Conducted Emission Test with Class 5 Peak Limits (Voltage Method)

Radiated EMI Performance (CISPR25 Radiated Emissions Test with Class 5 Peak Limits)

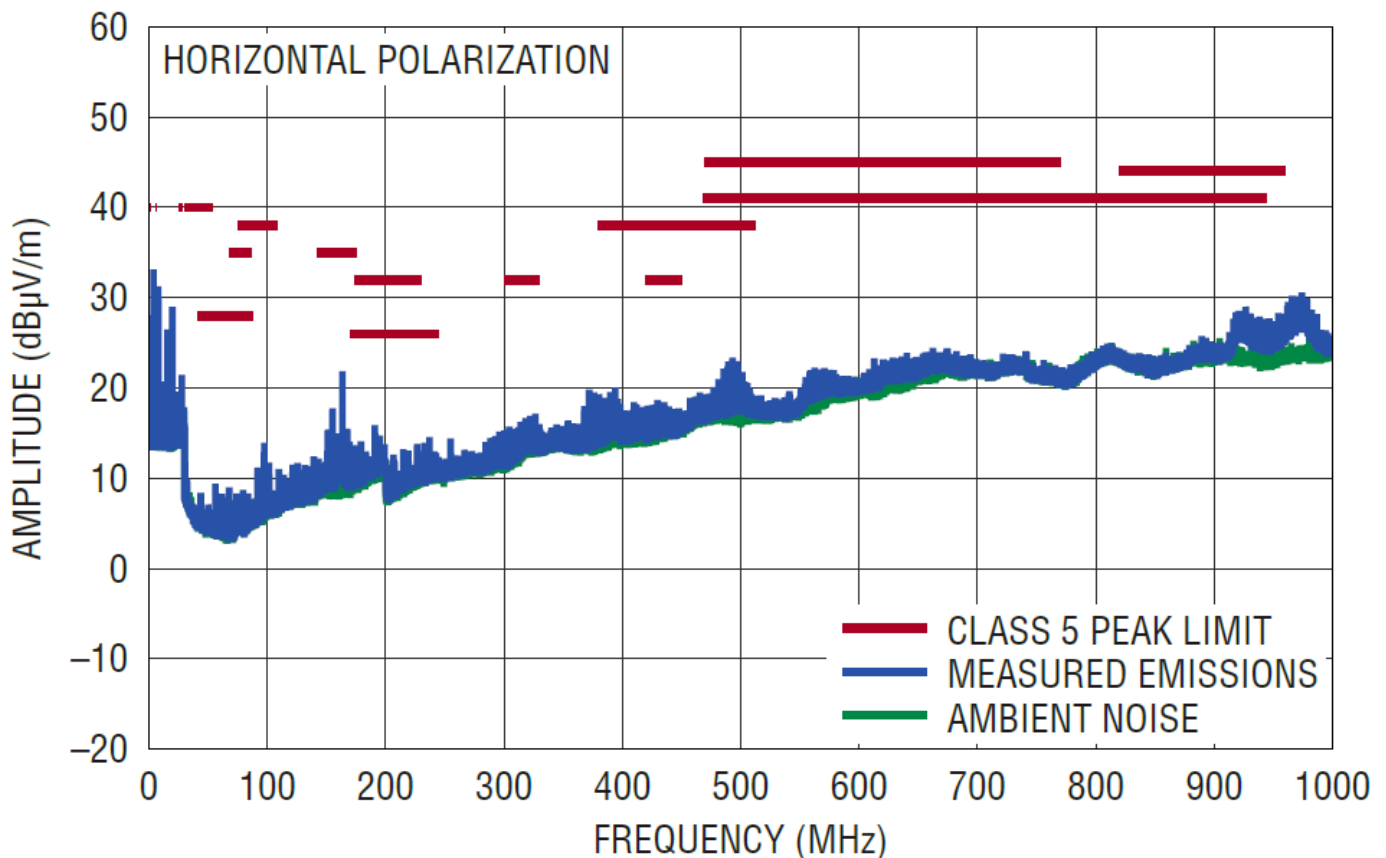

dc3092a F08

- DC3092A DEMO BOARD
(WITH EMI FILTER)
3.3V INPUT TO 1V OUTPUT AT 9.6A, f_{SW} = 2MHz
- CISPR25 Radiated Emission Test with Class 5 Peak Limits

THEORY OF OPERATION

Introduction to the DC3092A

The DC3092A demonstration circuit features the LTC3312SA, 5V, Dual 6A/Dual-Phase 12A Step-Down DC/DC Regulator. The LTC3312SA contains two mono-lithic, constant frequency, current mode step-down DC/DC converters. An oscillator, shared by two converters, with frequency set by a resistor on the RT pin, turns on the internal top power switch at the beginning of each clock cycle. The beginning of each clock cycle of the two converters are 180-degree out of phase. Current in the inductor then increases until the top switch comparator trips and turns off the top power switch. The peak inductor current, at which the top switch turns off, is controlled by the voltage on the internal VC node, which is the out-put of the error amplifier. When operating in dual-phase mode, VC of Buck1 is used to control the peak current for both buck power stages. The internal VC node is connected with internal compensator to stabilize the control loop. The error amplifier servos the VC node by comparing the voltage on the VFB pin with an internal 500mV reference. When the load current increases, it causes a reduction in the feedback voltage relative to the reference leading the error amplifier to raise the VC voltage until the average inductor current matches the new load current. When the top switch turns off, the synchronous bottom power switch turns on until the next clock cycle begins. In pulse skip mode and Burst Mode, the bottom switch also turns off when inductor current falls to zero. If overload conditions result in excessive current flowing through the bottom switch, the next clock cycle will be delayed until the switch current returns to a safe level. In Burst Mode, the error amplifier and most part of the internal circuitry is turned off until output voltage trips an output low comparator, during extreme light load condition, to improve light load efficiency. If the EN1 pin is low, the DC3092A is in shutdown and in a low quiescent current state. When the EN1 pin is above its threshold, the DC3092A will be enabled. The MODE/SYNC pin synchronizes the switching frequency to an external clock. It also sets the PWM mode. The PWM modes of operation are Burst, Pulse Skip and Forced Continuous. See the LTC3312SA data sheet for more detailed information. The maximum allowable operating frequency is influenced by the minimum on time of the top switch, the ratio of V_{OUT} to V_{IN} and the available inductor values. The maxi-

imum allowable operating frequency may be calculated in the formula below.

$$f_{SW(MAX)} = \frac{V_{OUT}}{V_{IN(MAX)} \cdot t_{ON(MIN)}} \quad (3)$$

Select an operating switching frequency below $f_{SW(MAX)}$. Typically, it is desired to obtain an inductor current of 30% of the maximum LTC3312SA single stage operating load, 6A. Use the formulas below to calculate the inductor value to obtain a 30% (1.8A) inductor ripple for the operating frequency.

$$L \geq \frac{V_{OUT}}{1.8A \cdot f_{SW}} \cdot \left(1 - \frac{V_{OUT}}{V_{IN(MAX)}} \right) \text{ for } \frac{V_{OUT}}{V_{IN(MAX)}} \leq 0.5 \quad (4)$$

$$L \geq \frac{0.25 \cdot V_{IN(MAX)}}{1.8A \cdot f_{SW}} \text{ for } \frac{V_{OUT}}{V_{IN(MAX)}} > 0.5 \quad (5)$$

The overall control loop of the converter can be tuned by output capacitors and feedforward capacitors. The LTC3312SA has been designed to operate at a high band-width for fast transient response capabilities. This reduces required output capacitance to meet the desired transient voltage range. C6 along with R1 provides a phase lead which will improve the phase margin. Loop stability is generally measured using the Bode Plot method of plotting loop gain in dB and phase shift in degrees. The 0dB crossover frequency should be less the 1/6 of the operating frequency to reduce the effects of added phase shift of the modulator. The control loop phase margin goal should be 45° or greater and a gain margin goal of 8dB or greater.

PARTS LIST

ITEM	QTY	REFERENCE	PART DESCRIPTION	MANUFACTURER/PART NUMBER
------	-----	-----------	------------------	--------------------------

Required Circuit Components

1	1	C1, C12, C13	CAP., 1 μ F, X7T, 6.3V, 20%, 0201	MURATA, GRM033D70J105ME01D
2	2	C2, C3	CAP., 22 μ F, X5R, 10V, 20%, 0603	MURATA, GRM188R61A226ME1 5D
3	4	C4, C5, C18, C19	CAP., 47 μ F, X6S, 6.3V, 20%, 0805	TAIYO YUDEN, JMK212BC6476 MG-T
4	1	C6	CAP., 10pF, C0G/NP0, 50V, \pm 0.5pF , 0402	TDK, C1005C0G1H100D050BA
5	1	C20	CAP., 0.015 μ F, X7R, 16V, 10%, 040 2	AVX, 0402YC153KAT2A
6	2	L1, L2	IND., 150nH, , 20%, 7.3A, 11m Ω	TDK, TFM252012ALMAR15MTAA
7	2	R1, R2	RES., 100k, 1%, 1/16W, 0402, AEC -Q200	NIC, NRC04F1003TRF
8	1	U1	IC, 5V, DUAL 6A/DUAL PHASE 12 A STEP-DOWN DC/DC REGULAT OR, LQFN	ANALOG DEVICES, LTC3312SA av#PBF

Additional Demo Board Circuit Components

1	2	C7, C8	CAP., 470 μ F, TANT, POSCAP, 6.3V, 20%, 7343, 18m Ω	PANASONIC, 6TPE470MI
2	1	C9	CAP., 0.1 μ F, X7R, 25V, 10%, 0402	MURATA, GCM155R71E104KE02D
3	2	C10, C11	CAP., 10 μ F, X7S, 6.3V, 20%, 0603	TDK, C1608X7S0J106M080AC
4	2	C14, C21	CAP., 1000pF, X7R, 50V, 20%, 0402, 3-TERM, X2Y EMI FILTER	JOHANSON DIELECTRICS, 500X07W102MV4T
5	1	C15	CAP., 1 μ F, X7R, 6.3V, 10%, 0402	MURATA, GRM155R70J105KA12D
6	2	C16, C17	CAP., 0.22 μ F, X7R, 6.3V, 20%, 0603	JOHANSON DIELECTRICS, 6R3X14W224MV4T
7	1	L3	IND., 100 Ω AT 100MHz, FERRITE BEAD, 25%, 8A, 6m Ω , 1812	WURTH ELEKTRONIK, 74279226101
8	1	Q1	XSTR., MOSFET, N-CH, 40V, 15.9A, PPAK SO-8	VISHAY, SIR426DP-T1-GE3
9	1	R3	RES., 20 Ω , 1%, 1/16W, 0402	NIC, NRC04F20R0TRF
10	2	R5, R10	RES., 10k, 5%, 1/16W, 0402	NIC, NRC04J103TRF
11	1	R6	RES., 1M, 1%, 1/16W, 0402	NIC, NRC04F1004TRF
12	1	R7	RES., 249k, 1%, 1/16W, 0402	NIC, NRC04F2493TRF
13	1	R8	RES., 100k, 5%, 1/16W, 0402	YAGEO, RC0402JR-07100KL
14	1	R9	RES., 0 Ω , 1/16W, 0402	NIC, NRC04Z0TRF
15	1	R11	RES., 0.02 Ω , 1%, 10W, 2818, SENSE	VISHAY, WSHP2818R0200FEA
16	1	TP1	CONN., U.FL, RECEPT, ST SMD, 0 Hz to 6GHz 50 Ω	HIROSE ELECTRIC, U.FL-R-SMT-1(10)
17	1	TP1_PLUG	CONN U.FL PLUG STR 50 Ω SMD	HIROSE ELECTRIC, U.FL-PR-SMT2.5-1(10)

Hardware: For Demo Board Only

1	12	E1-E3, E5, E12, E14, E15, E16, E19, E21, E22, E32	TEST POINT, TURRET, 0.064" MT G. HOLE, PCB 0.062" THK	MILL-MAX, 2308-2-00-80-00-00-07-0
2	6	E4, E7, E11, E13, E18, E20	TEST POINT, TURRET, 0.094" MT G. HOLE, PCB 0.062" THK	MILL-MAX, 2501-2-00-80-00-00-07-0
3	5	E6, E8-E10, E17	CONN., BANANA JACK, FEMALE, THT, NON- INSULATED, SWAGE, 0.218"	KEYSTONE, 575-4
4	1	JP1	CONN., HDR, MALE, 1x4, 2mm, VERT, ST, THT	WURTH ELEKTRONIK, 6200041 1121
5	1	JP2	CONN., HDR, MALE, 1x3, 2mm, VERT, ST, THT	WURTH ELEKTRONIK, 6200031 1121
5	4	MP1-MP4	STANDOFF, NYLON, SNAP-ON, 0.50"	WURTH ELEKTRONIK, 7029350 00
6	2	XJP1, XJP2	CONN., SHUNT, FEMALE, 2 POS, 2mm	WURTH ELEKTRONIK, 6080021 3421

SCHEMATIC DIAGRAM

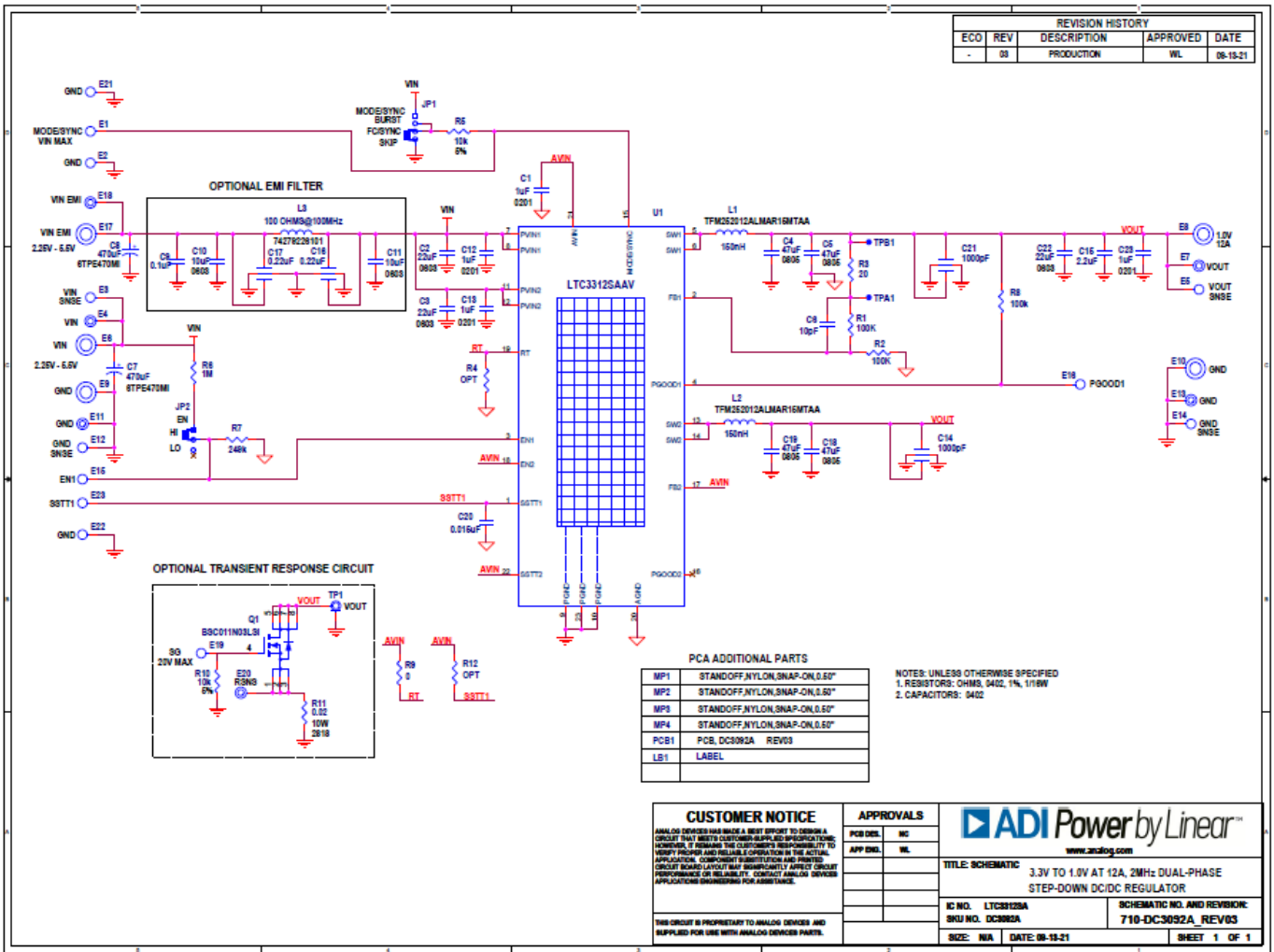

ESD Caution

ESD (electrostatic discharge) sensitive device. Charged devices and circuit boards can discharge without detection. Although this product features patented or proprietary protection circuitry, damage may occur on devices subjected to high energy ESD. Therefore, proper ESD precautions should be taken to avoid performance

degradation or loss of functionality.

Legal Terms and Conditions

By using the evaluation board discussed herein (together with any tools, components documentation or support materials, the "Evaluation Board"), you are agreeing to be bound by the terms and conditions set forth below ("Agreement") unless you have purchased the Evaluation Board, in which case the Analog Devices Standard Terms and Conditions of Sale shall govern. Do not use the Evaluation Board until you have read and agreed to the Agreement. Your use of the Evaluation Board shall signify your acceptance of the Agreement. This Agreement is made by and between you ("Customer") and Analog Devices, Inc. ("ADI"), with its principal place of business at One Technology Way, Norwood, MA 02062, USA. Subject to the terms and conditions of the Agreement, ADI hereby grants to Customer a free, limited, personal, temporary, non-exclusive, non-sublicensable, non-transferable license to use the Evaluation Board FOR EVALUATION PURPOSES ONLY. Customer understands and agrees that the Evaluation Board is provided for the sole and exclusive purpose referenced above, and agrees not to use the Evaluation Board for any other purpose. Furthermore, the license granted is expressly made subject to the following additional limitations: Customer shall not

1. rent, lease, display, sell, transfer, assign, sublicense, or distribute the Evaluation Board; and
2. permit any Third Party to access the Evaluation Board. As used herein, the term "Third Party" includes any entity other than ADI, Customer, their employees, affiliates and in-house consultants. The Evaluation Board is NOT sold to Customer; all rights not expressly granted herein, including ownership of the Evaluation Board, are reserved by ADI. CONFIDENTIALITY. This Agreement and the Evaluation Board shall all be considered the confidential and proprietary information of ADI. Customer may not disclose or transfer any portion of the Evaluation Board to any other party for any reason. Upon discontinuation of use of the Evaluation Board or termination of this Agreement, Customer agrees to promptly return the Evaluation Board to ADI. ADDITIONAL RESTRICTIONS. Customer may not disassemble, decompile or reverse engineer chips on the Evaluation Board. Customer shall inform ADI of any occurred damages or any modifications or alterations it makes to the Evaluation Board, including but not limited to soldering or any other activity that affects the material content of the Evaluation Board. Modifications to the Evaluation Board must comply with applicable law, including but not limited to the RoHS Directive. TERMINATION. ADI may terminate this Agreement at any time upon giving written notice to Customer. Customer agrees to return to ADI the Evaluation Board at that time. LIMITATION OF LIABILITY. THE EVALUATION BOARD PROVIDED HEREUNDER IS PROVIDED "AS IS" AND ADI MAKES NO WARRANTIES OR REPRESENTATIONS OF ANY KIND WITH RESPECT TO IT. ADI SPECIFICALLY DISCLAIMS ANY REPRESENTATIONS, ENDORSEMENTS, GUARANTEES, OR WARRANTIES, EXPRESS OR IMPLIED, RELATED TO THE EVALUATION BOARD INCLUDING, BUT NOT LIMITED TO, THE IMPLIED WARRANTY OF MERCHANTABILITY, TITLE, FITNESS FOR A PARTICULAR PURPOSE OR NONINFRINGEMENT OF INTELLECTUAL PROPERTY RIGHTS. IN NO EVENT WILL ADI AND ITS LICENSORS BE LIABLE FOR ANY INCIDENTAL, SPECIAL, INDIRECT, OR CONSEQUENTIAL DAMAGES RESULTING FROM CUSTOMER'S POSSESSION OR USE OF THE EVALUATION BOARD, INCLUDING BUT NOT LIMITED TO LOST PROFITS, DELAY COSTS, LABOR COSTS OR LOSS OF GOODWILL. ADI'S TOTAL LIABILITY FROM ANY AND ALL CAUSES SHALL BE LIMITED TO THE AMOUNT OF ONE HUNDRED US DOLLARS (\$100.00). EXPORT. Customer agrees that it will not directly or indirectly export the Evaluation Board to another country, and that it will comply with all applicable United States federal laws and regulations relating to exports. GOVERNING LAW. This Agreement shall be governed by and construed in accordance with the substantive laws of the Commonwealth of Massachusetts (excluding conflict of law rules). Any legal action regarding this Agreement will be heard in the state or federal courts having jurisdiction in Suffolk County, Massachusetts, and Customer hereby submits to the personal jurisdiction and venue of such courts. The United Nations Convention on Contracts for the International Sale of Goods shall not apply to this Agreement and is expressly disclaimed.

Documents / Resources

	<p>ANALOG DEVICES DC3092A Evaluation Board [pdf] Instruction Manual DC3092A, Evaluation Board, DC3092A Evaluation Board</p>
---	---

References

- [Mixed-signal and digital signal processing ICs | Analog Devices](#)

[Manuals+](#)